

# Harmonic load modulation in Doherty amplifiers

K.W. Eccleston, K.J.I. Smith, P.T. Gough and S.I. Mann

In a Doherty amplifier employing a class-B main amplifier and a class-C peaking amplifier, harmonics are normally suppressed at each amplifier. If odd harmonic currents generated by the peaking amplifier are permitted to flow into the main amplifier, the loadline of the main amplifier is shaped in such a manner as to allow a lower supply voltage to be used.

**Introduction:** As the RF power amplifier draws a significant amount of current from the power supply, it is important to maximise its DC to RF conversion efficiency over a wide dynamic range. However, a conventional RF power amplifier only achieves maximum efficiency at maximum drive and this means low average efficiency when the envelope is modulated. The Doherty amplifier [1] alleviates this problem by using two transistors with one, the main amplifier, operating over the entire range of input powers, and the other, the peaking amplifier, only operating over the upper end (usually the top 6 dB) of the dynamic range. Over the upper end of the dynamic range, the load resistance seen by the main amplifier decreases with input level, causing it to operate at maximum efficiency in this range; this is called load modulation. Usually the main amplifier operates in class-B, and the peaking amplifier in class-C. It is often assumed that harmonic suppression occurs within these two amplifiers, and only the fundamental plays a role in the Doherty amplifier operation.

In this Letter we show that odd harmonics generated in the peaking amplifier can be used by the main amplifier to further enhance efficiency. We call this harmonic modulation, and the main amplifier operates in a similar manner to class-F operation [2]; but this approach is distinct from class-F Doherty amplifiers that use separate class-F main and peaking amplifiers [3, 4].

**Principle of operation:** Fig. 1 shows a schematic of a Doherty amplifier in which both fundamental and odd harmonic modulation occurs. For brevity, details of the gate bias circuits and input signal feeding are not shown. The capacitors are assumed to have negligible impedance to the RF signal, and the FET drains behave as ideal dependent current sources. The main amplifier FET, M1, has a class-B bias and the peaking amplifier FET, M2, has a class-C bias. M2 is biased so that it conducts only for the upper end of the dynamic range. The drain bias supply feeds ( $\lambda/4$  short-circuit stubs) provide inherent even harmonic suppression. The characteristic impedance of the quarter-wave transformer coupling the main and peaking amplifiers is  $2Z_o$ , where  $Z_o$  is the load impedance.

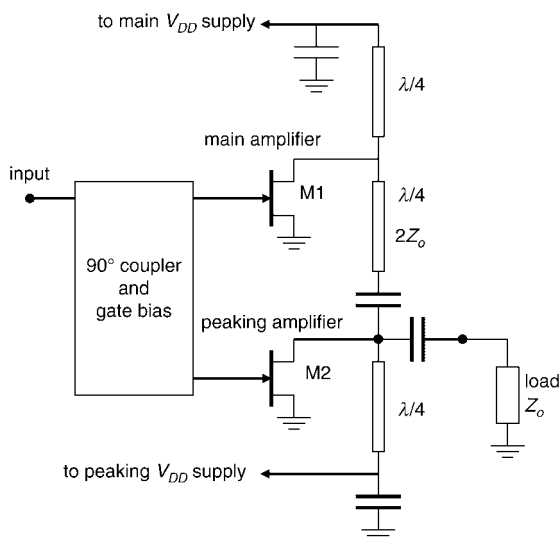

Fig. 1 Doherty amplifier that employs odd-harmonic load modulation

At the lower end of the dynamic range where M2 is completely off, M1 operates similar to a class-B amplifier with a constant load impedance of  $4Z_o$ . At the upper end of the dynamic range, M2 conducts

for a portion of the cycle and its drain current contains the fundamental and all harmonics. The fundamental component of the M2 drain current is fed directly to the load and causes the usual load modulation of M1. The load impedance for M2 is zero at all harmonics, which means that the output voltage is sinusoidal, with the even harmonics shunted to ground via the stub nearest M2, and the odd harmonics shunted to ground via the stub nearest M1. The odd harmonic voltage standing-waves established on the  $\lambda/4$  transformer linking M1 and M2 are maximum at the drain of M1, and hence the main amplifier is load modulated at both the fundamental and the odd harmonics. These odd harmonics shape the drain voltage waveform of M1 to resemble a clipped sine-wave.

It must be emphasised that clipping is not due to overdriving M1 but to odd harmonics originating from M2. The clipped sine-wave drain voltage waveform at M1 means that the supply voltage for M1 can be reduced thereby reducing the DC power supplied to M1. Therefore, the operation of the main amplifier, when the peaking amplifier operates, is similar to class-F operation [2] but with the odd harmonics generated by the peaking amplifier. This is in contrast to normal class-F amplifiers where the odd harmonics are internally generated requiring a class AB bias [2].

**Simulation:** To demonstrate the advantage of this operating principle, three Doherty amplifiers were simulated using a harmonic balance simulator: (i) conventional Doherty amplifier, (ii) Doherty amplifier employing odd harmonic load modulation and (iii) conventional Doherty amplifier with reduced main amplifier supply voltage. In the case of the conventional Doherty amplifiers, harmonics were internally suppressed in both the main and the peaking amplifiers.

In all cases, the FET drain current,  $I_D$ , was related to the gate-source voltage,  $V_{GS}$ , and drain-source voltage,  $V_{DS}$ , by:

$$I_D = I_{DSS}(1 - V_{GS}/V_T) \tanh(\alpha V_{DS}) \quad (1)$$

for  $V_{GS} > V_T$  and zero otherwise, where  $V_T$  is the threshold voltage and  $\tanh(x)$  is a polynomial approximation to the hyperbolic tangent function. Equation (1) is a realistic representation of practical microwave and RF power FETs.

In this work:  $V_T = -2V$ ,  $\alpha = 2.5$ ,  $I_{DSS} = 100$  mA for the main amplifier,  $I_{DSS} = 250$  mA for the peaking amplifier, and  $Z_o = 50 \Omega$ . The supply voltage for the peaking amplifier was 6 V in all cases. The supply voltage for the main amplifier was 6 V for the conventional Doherty amplifier, and 5 V for both the harmonic modulated Doherty amplifier and the conventional Doherty amplifier with reduced main amplifier supply voltage. Without loss of generality, the amplifiers were designed to operate, and were simulated, at 1 GHz. The simulations confirmed normal operation of the conventional Doherty amplifier and confirmed the waveform shaping effects in the harmonic modulated Doherty amplifier. In all cases, the output voltage was sinusoidal over the entire dynamic range.

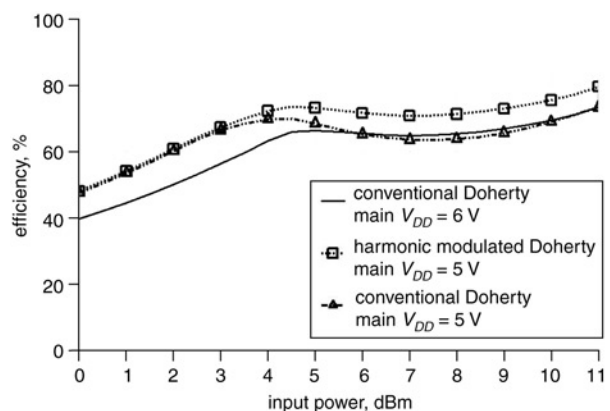

Fig. 2 DC to RF conversion efficiency against input power of Doherty amplifiers

Fig. 2 shows the DC to RF conversion efficiency of all three amplifiers against input power. It is clear that the two cases of a 5 V main amplifier supply have improved efficiency, compared to the conventional case with a 6 V main amplifier supply, for input levels up to about 3 dBm where the peaking amplifier turns on, and is attributed to

reduced main amplifier supply voltage. For input levels above 3 dBm, the conventional Doherty amplifier with a 5 V main amplifier supply is no better than with a 6 V main amplifier supply, whereas the harmonic modulated Doherty amplifier offers significantly increased efficiency.

Fig. 3 shows the simulated load trajectories for the conventional Doherty amplifier with reduced supply voltage and harmonic modulated Doherty amplifier with an input level of 8 dBm. Superimposed on Fig. 3 are the drain I/V characteristics calculated from (1). Clearly, in the former case, the FET of the main amplifier has been driven well into its triode region, whereas harmonic modulation has ensured that this does not occur in the latter case. Driving the FET into its triode region results in drain current distortion and, moreover, reduction in output power, and this explains why reduction in supply voltage in a conventional Doherty amplifier did not yield efficiency improvement for input levels above 3 dBm. The looping seen for the conventional Doherty amplifier case is due to the harmonic trap component value round-off error and its very high  $Q$ .

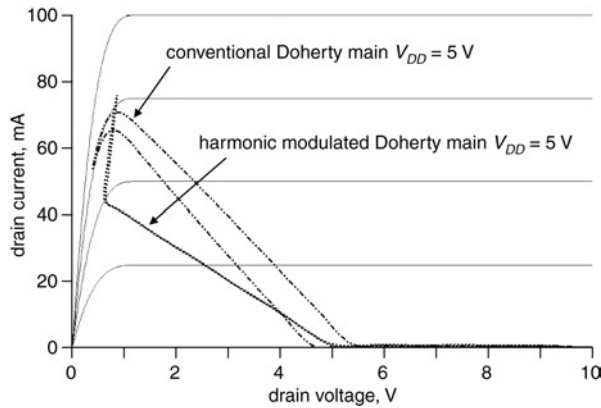

Fig. 3 Main amplifier FET drain I/V characteristics with superimposed load trajectories at input power of 8 dBm

**Conclusions:** It has been shown that the odd harmonics generated in the class-C peaking amplifier of a Doherty amplifier can be used to shape the drain voltage waveform of the main amplifier allowing it to operate at a reduced supply voltage, thereby increasing efficiency. Quarter-wave bias feed stubs for both the main and peaking amplifiers ensure that all harmonics are suppressed at the output of the amplifier. The topology is simple, not requiring other harmonic resonators.

© The Institution of Engineering and Technology 2008

1 November 2007

Electronics Letters online no: 20083160

doi: 10.1049/el:20083160

K.W. Eccleston, K.J.I. Smith and P.T. Gough (*Department of Electrical and Computer Engineering, University of Canterbury, Christchurch, New Zealand*)

E-mail: kim.eccleston@canterbury.ac.nz

S.I. Mann (*Tait Electronics Ltd., 535 Wairakei Rd, Christchurch, New Zealand*)

#### References

- 1 Doherty, W.H.: 'A new high efficiency power amplifier for modulated waves', *Proc. IRE*, 1936, **24**, (9), pp. 1163–1182
- 2 Colantonio, P., Giannini, F., Leuzzi, G., and Limiti, E.: 'On the class-F power amplifier design', *Int. J. RF Microw. Comput. Aided Eng.*, 1999, **9**, (2), pp. 129–149
- 3 Suzuki, Y., Hirota, T., and Nojima, T.: 'Highly efficient feed-forward amplifier using a Class-F Doherty amplifier', *IEEE MTT-S Int. Microw. Symp. Dig.*, 2003, pp. 77–80
- 4 Goto, S., Kunii, T., Inoue, A., Izawa, K., Ishikawa, T., and Matsuda, Y.: 'Efficiency enhancement of Doherty amplifier with combination of class-F and inverse class-F schemes for S-band base station application', *IEEE MTT-S Int. Microw. Symp. Dig.*, 2004, pp. 839–842