

# Standardising Design Fires For Residential and Apartment Buildings: Upholstered Furniture Fires

by

Elizabeth A. Young

Supervised by:

Dr Charles Fleischmann

Fire Engineering Research Report

April 2007

A thesis submitted in partial fulfilment of the requirements for the Degree of  
Master of Engineering in Fire Engineering

Department of Civil Engineering  
University of Canterbury  
Private Bag 4800  
Christchurch, New Zealand

For a full list of reports please visit [http://www.civil.canterbury.ac.nz/fire/fe\\_resrch\\_reps.shtml](http://www.civil.canterbury.ac.nz/fire/fe_resrch_reps.shtml)

## Abstract

This purpose of this research was to develop a credible set of furniture design fires for residential/apartment buildings and determine a methodology for incorporating compartment effects in design fires. Design fires can be defined using various outputs, the most important being the HRR profile, and depending on the application the following may also be relevant:

- Smoke production rates
- Soot yield
- Species production rates
- Temperature profiles
- Visibility
- Heat fluxes
- Mass loss rate of the fuel
- Flame spread

There were three phases to this project: The first phase of this project was a comprehensive data and literature review to determine the amount of experimental data available and commonly accepted burning characteristics for upholstered furniture; armchairs, 2-seater sofas, 3-seater sofas, beds and bedding assemblies, and commonly accepted burning characteristics and compartment effects. A large proportion of the review provided only qualitative guidance for design fires.

In the second phase the data collected during the review was collated and used to quantitatively analyse key fire characteristics. These were

- peak HRR,
- time to peak HRR,
- growth rate,
- total heat released and
- maximum CO/CO<sub>2</sub> ratio.

A methodology was developed to statistically analyse experimental data using BestFit, and where there was sufficient data the 98<sup>th</sup> percentile of the statistical analysis was used as a quantitative guide for furniture design fires. Similarly, compartment effects were incorporated into the design fires by analysing and comparing the experimental data from free burn and room burn tests of the same furniture item. The same statistical analysis was used to determine likely changes in the key fire characteristics mentioned above.

A methodology for determining design fires for upholstered furniture was devised, however the small number of data sets available for analysis meant the quantitative results were only indicative.

The third phase was to attempt to model furniture fires using FDS, which determined that at the time of this project, FDS was not capable of modelling simple furniture fires accurately. The simulation results varied significantly from the experimental results and a number of limitations were identified. Therefore FDS should not be used to create design fires using the heat of combustion method, which relies on the users' definition of material properties.

## Acknowledgments

I would like to sincerely thank Dr Charley Fleischmann who supervised this project, and provided technical data, guidance and enthusiasm.

This project was part of a CSIRO, BRANZ, University of Canterbury joint venture; I would like to thank all those involved, for their input, and the Building Research Levy for the scholarship, which made this research possible. Special thanks to Colleen Wade and Amanda Edwards for their invaluable input, the hours they put in proofreading drafts and all their suggested improvements.

I really appreciate the help and support of those involved in the fire programme, especially Dr Michael Spearpoint and Professor Andy Buchanan.

I would also like to thank the following: The Engineering Library staff in particular Christine Mckee and Dave Lane for all their help with the literature review. The civil support staff for their assistance with anything administrative, especially Belinda Lansley.

To a very special group of friends, who endured proofreading my thesis and corrected numerous grammatical errors: Melanie Cussins, Garrick Thorn, Geoff Merryweather and Thomas Haydon, a big big thank you.

Last but not least thank you to all my friends and family, who wanted to see me complete this project, your support was invaluable.

# Table of Contents

Abstract .....	II
Acknowledgments .....	IV
List of Figures .....	VII
List of Tables .....	X
1 Introduction .....	1
1.1 Impetus for this Research.....	1
1.2 Background .....	2
1.3 Objectives of this Report.....	6
1.4 Methodology / Project Overview .....	7
2 Literature Review – Characteristics of Bed and Bedding Fires .....	8
2.1 Literature Annotation.....	8
2.2 Literature Summary of Beds and Bedding Fires.....	30
3 Literature Review – Characteristics of Upholstered Furniture Fires.....	32
3.1 Literature Annotation.....	32
3.2 Literature Summary of Upholstered Furniture Fires .....	63
4 Literature Review – Characteristic Compartment Effects.....	66
4.1 Literature Annotation.....	66
4.2 Literature Summary of Compartment Effects.....	83
5 Literature Review Summary.....	85
5.1 Bedding Assembly Fire Characteristics.....	85
5.2 Upholstered Furniture Fire Characteristics .....	85
5.3 Compartment Effect Fire Characteristics.....	87
6 Furniture Data .....	89
6.1 Available Databases.....	89
6.2 Collating Upholstered Furniture Data .....	95
6.3 Access Database .....	97
6.4 Summary of Upholstered Furniture Data .....	99
7 Specifying Upholstered Furniture Fires.....	102
7.1 Statistical Analysis of Existing Data.....	103
7.2 Growth Rate.....	104
7.3 Free Burn Characteristics.....	106
7.4 Compartment Effects.....	118
7.5 Limitations .....	127
8 FDS Simulations.....	130
8.1 Modelling Upholstered Chairs.....	130
8.2 Modelling Results and Discussion.....	142
8.3 Summary .....	164
9 Conclusions .....	168
9.1 General.....	168
9.2 Recommendations .....	170
9.3 Future Research .....	172
10 References .....	174
11 Appendices .....	180

Appendix A: Upholstered furniture Database ..... 180  
Appendix B: Extracts from Bestfit manuals ..... 180  
Appendix C: Experimental data on growth rates..... 180  
Appendix D: Analysis of experimental data ..... 180

## List of Figures

Figure 1-1: Location of Fires in New Zealand 1999 - 2003, Extracted from NZFS (2004).....	3
Figure 1-2: Location of Fire Fatalities in New Zealand 1999 - 2003, Extracted from NZFS (2004).....	3
Figure 2-1: Bedding assembly configuration for fire testing. Adapted from Benisek et al. (1985). ....	8
Figure 2-2: Room-corridor configuration. Extracted from Woolley et al. (1976). ....	9
Figure 2-3: Room-corridor arrangement used in the experiments. Extracted from Paul (1989).....	12
Figure 2-4: Location of ignition sources. Extracted from Paul (1989). ....	13
Figure 2-5: Multi-room arrangement used for mattress fire testing. Extracted from Luo & Beck (1996).14	
Figure 2-6: Fuel configuration used. Extracted from Luo & Beck (1996). ....	15
Figure 2-7: TB 129 experimental set up. Extracted from Nurbakhsh & McCormack (1998). ....	16
Figure 2-8: Schematic of the cross-sectional view of the mattress and foundation structure. (Ohlemiller & Gann (2003); Ohlemiller & Gann (2002); Ohlemiller (2003); Ohlemiller et al. (2000).....	19
Figure 2-9: Schematic of the set up and igniter position for bedding tests on inert mattresses. Extracted from Ohlemiller et al. (2000).....	20
Figure 2-10: Location of the ignition sources. Extracted from Benisek et al. (1985).....	26
Figure 2-11: Schematic of the set up for the room tests conducted by Lee (1985). ....	27
Figure 2-12: Heat release rate profiles of a bedroom with plywood wall linings. Note the change in scale. Extract taken from Lee (1985). ....	29
Figure 2-13: HRR curves for various pillows. Extracted from Babrauskas (1985).....	29
Figure 3-1: Configurations of chair mock-ups. Extracted from Krasny & Babrauskas (1984). ....	32
Figure 3-2: Examples of HRR profiles for easy chairs. Note the difference in scale between a) and b). Extracted from Lawson, J. R. W. et al. (1984). ....	34
Figure 3-3: Example of HRR profiles for a sofa and loveseat. Note the difference in scale between a) and b). Extracted from Lawson, J. R. W. et al. (1984). ....	35
Figure 3-4: Example HRR profiles for office chairs. Note the difference in scale between a) and b). Extracted from Lawson, J. R. W. et al. (1984). ....	36
Figure 3-5: Examples of chair designs used in testing. Extracted from Babrauskas, V. (1983).....	37
Figure 3-6: Upholstered furniture designs tested. Extracted from Enright et al. (2001). ....	41
Figure 3-7: A schematic of the layout used for testing armchairs in a room calorimeter. ....	44
Figure 3-8: Configuration of the full-scale chairs. Extracted from Ohlemiller & Villa (1992).....	48
Figure 3-9: TB 133 Ignition Source 1. Extracted from Ohlemiller & Villa (1992).....	49
Figure 3-10: Mock-up configuration. Extracted from Ohlemiller & Shields (1995).....	51
Figure 3-11: The HRR curve for a 'nylon/fibreglass/TB117' combination chair.....	53
Figure 3-12: Locations of ignition used for the testing of various chairs. ....	55
Figure 4-1: Pile Configuration of Fuel. Extracted from Harmathy (1979).....	67
Figure 4-2: Room Configuration for Experiments. Extracted from Babrauskas (1984).....	68
Figure 4-3: Observed air flow through the opening. Extracted from Babrauskas (1984).....	69
Figure 4-4: Test Configuration. Extracted from Fleischmann & Parkes (1997).....	72

Figure 4-5: Compartment Configuration Parkes & Fleischmann (2005) .....	74
Figure 4-6: Test Chair, Extracted from Girgis (2000) .....	81
Figure 6-1: Example of Item in HRR Database Spearpoint (2001a) .....	90
Figure 6-2: Example of Data in Initial Fires Database Särndqvist (1993) .....	93
Figure 6-3: Example of Item Data from SP Fire Database .....	94
Figure 6-4: A screen shot of data points translated using Grab It! XP.....	96
Figure 6-5: Example of Excel Worksheet of Furniture Item .....	96
Figure 6-6: Example of Data from the Upholstered Furniture Access Database.....	98
Figure 7-1: Example of Delayed Growth Rate of an Upholstered Furniture Item.....	105
Figure 7-2: Distribution of Growth Rates from Experimental Data .....	106
Figure 7-3: Peak HRR for Armchairs .....	107
Figure 7-4: Peak HRR for 2-Seater Sofas .....	108
Figure 7-5: Peak HRR for 3-Seater Sofas .....	108
Figure 7-6: Distribution Curve of Armchair Peak HRRs – Experimental Data and Normal Curve.....	110
Figure 7-7: Distribution Curve of Armchair Peak HRRs – Data as a Cumulative Distribution .....	110
Figure 7-8: Time to Peak HRR for Armchairs .....	112
Figure 7-9: Time to Peak HRR for 2-seater Sofas .....	113
Figure 7-10: Total Heat Released of Upholstered Furniture .....	115
Figure 7-11: Preliminary Design Fires for Upholstered Furniture Items.....	118
Figure 7-12: Distribution of changes to Peak HRR between free burn and room burn experiments ....	120
Figure 7-13: Distribution of changes in Time to Peak HRR between free burn and room burn experiments .....	121
Figure 7-14: Distribution of changes in Total Heat Released between free burn and room burn experiments .....	122
Figure 7-15: Distribution of changes in Effective Heat of Combustion between free burn and room burn experiments .....	123
Figure 7-16: Preliminary Compartment Design Fires for Upholstered Furniture Items.....	125
Figure 7-17: Preliminary Design Fires for Armchairs.....	126
Figure 7-18: Preliminary Design Fires for 2-seater Sofas.....	126
Figure 7-19: Preliminary Design Fires for 3-seater Sofas.....	127
Figure 8-1: FDS defined surface property ‘UPHOLSTERY’ .....	131
Figure 8-2: FDS defined reaction ‘POLYURETHANE’ .....	132
Figure 8-3: Second Modelling Approach of Armchair.....	132
Figure 8-4: Diagrammatic of experimental furniture item and FDS representation, .....	134
Figure 8-5: Part of an FDS Input File, Defining the Armchair Version 1 .....	135
Figure 8-6: Part of the FDS Input File, Defining the Armchair Version 2 .....	136
Figure 8-7: Part of the FDS Input File Defining the Material Properties of the Surfaces.....	137
Figure 8-8: HRR profiles of Experimental Results Denize (2000) to be Compared with Simulation Results.....	138



Figure 8-9: FDS Simulation Comparisons – Free Burn, ISO Room .....	139
Figure 8-10: HRR profiles of Experimental Results from Room Calorimeter Tests Girgis (2000) to be Compared with ISO Room Simulation Results .....	139
Figure 8-11: Different Burner Configurations.....	141
Figure 8-12: 3-Seater Sofa FDS Simulation compared with Experimental Results Lawson, J. R. W. et al. (1984) .....	144
Figure 8-13: 2-Seater Sofa compared with Experimental Results Enright (1999).....	144
Figure 8-14: Armchair Simulations Compared with Experimental Data Denize (2000)) .....	145
Figure 8-15: Base Case Freeburn Simulation Compared with Experimental Data.....	146
Figure 8-16: HRR Profiles of all the Freeburn Armchair Simulation Compared to Experimental Results .....	150
Figure 8-17: Comparison between the Base case and the ISO room base case.....	152
Figure 8-18: HRR Profiles of all the ISO Room Armchair Simulations Compared to Free-burn Armchair Simulations .....	155
Figure 8-19:- HRR Profiles for ISO Room Armchair Simulations Compared with ISO Room Experimental Results.....	157
Figure 8-20: Case 8 (Smaller Grid Sizes) – Free Burn HRR Profile.....	160
Figure 8-21:- HRR Profiles for Case 8 Armchair Simulations – Different Grid Sizes, Compared with Free burn Experimental Results .....	161
Figure 8-22: Case 9 (300 mm square burner) – Free Burn HRR Profile .....	162
Figure 8-23: Case 10 (smaller grid & square ring burner) – Free Burn HRR profile.....	163
Figure 8-24: Case 10 (square ring burner), Compared with Case 8 Simulation Results .....	163
Figure 9-1: Preliminary Design Fires for Upholstered Furniture Items .....	171

## List of Tables

Table 2-1	Results from the king sized bedding assembly tests. Adapted from Ohlemiller & Gann (2002).	22
Table 2-2	Features of Burning Bedding and Gas Burners as Ignition Sources.	24
Table 3-1:	Upholstered furniture items tested by Lawson, J. R. W. et al. (1984)	33
Table 3-2:	Fabrics and Foam/Fillings tested by Kallonen et al. (1985).	59
Table 4-1:	Description of the room tests. Extracted from Babrauskas (1984).	69
Table 4-2:	Summary of Results. Adapted from Fleischmann & Parkes (1997).	73
Table 4-3:	Selected Results from the Compartment Tests with a Door Sized Vent,	74
Table 4-4:	Summary of experimental results showing layer behaviour.	75
Table 4-5:	Summary of Results from Tests where Vent Width = Compartment Width. Extracted from Thomas and Bennetts (1999).	78
Table 4-6:	Summary of Results from Remaining Tests. Extracted from Thomas and Bennetts (1999).	79
Table 4-7:	Summary of Results from the Comparison of Compartment and Free Burn Experiments. Extracted from Girgis (2000)	81
Table 6-1:	Data Available on HRR Database Spearpoint (2001a)	89
Table 6-2:	Data Available on FASTDATA NIST (1999)	91
Table 6-3:	Items Available on the Initial Fires Database Särndqvist (1993)	93
Table 6-4:	Data available in the Access Database.	100
Table 6-5:	References for the Data Sets in the Access Database	100
Table 7-1:	Growth Rates of Fires.	104
Table 7-2:	Summary of Results for Peak HRR calculated for Data	109
Table 7-3:	Comparison of Peak HRR Results using Experimental Data and Distribution Fitting	111
Table 7-4:	Summary of Results for Time to Peak HRR.	113
Table 7-5:	Comparison of the Time to Peak HRR Results using Experimental Data and Distribution Fitting.	114
Table 7-6:	Summary of Results for THR	116
Table 7-7:	Comparison of the Total Heat Released Results using Experimental Data and Distribution Fitting.	116
Table 7-8:	Data Used in Determining Compartment Effects.	119
Table 7-9:	Data Compartment Design Fire.	125
Table 8-1:	Surface Properties of Upholstery Composites.	133
Table 8-2:	Properties of PU foam/ Polyester fabric composite	136
Table 8-3:	Series 2 Simulations	137
Table 8-4:	Upholstery Surface Properties	142
Table 8-5:	Total Heat Released of Base Case compared with Experimental Results	147
Table 8-6:	Summary of Series 2 Simulations.	148
Table 8-7:	Peak HRR - Simulation Comparison to Experimental Results.	149

Table 8-8: Potential Fuel in Simulation Chairs.....	151
Table 8-9: Potential Fuel in Experimental Chairs.....	151
Table 8-10: ISO Room Simulation compared with Free Burn Simulation.....	153
Table 8-11: Comparison of Total Heat Released, Free burn simulation compared with ISO room simulation.....	153
Table 8-12: THR in Free burn Experiments compared to the THR in ISO Room Experiments.....	158
Table 8-13: Series 4 Results .....	159
Table 8-14: Series 4 THR results comparison with experimental results .....	159
Table 9-1: Design Fire – Free Burn Recommendations .....	170
Table 9-2: Design Fire – Compartment Effects Recommendations .....	171

# 1 Introduction

## 1.1 *Impetus for this Research*

The success of performance-based codes can be facilitated by the development of standardised design fires so that there will be greater consistency in the application and approval of performance-based fire engineering design of buildings. Currently there is no such standardisation for design fires which leads to different fire safety designers using different fire characteristics for their fire safety analysis and a lack of uniformity in the levels of safety provided. Without standardisation of the design fires the current practice will continue and approval of fire safety performance-based design will be at risk of returning to more prescriptive requirements allowing for less flexibility in design. The objective of this research is to develop a credible set of furniture design fires for residential/apartment buildings and determine a methodology for incorporating compartment effects in design fires.

As the New Zealand building industry becomes more focussed on performance based design, the choices designers may will come under greater scrutiny. Designers need to be able to justify their decisions and document them sufficiently to satisfy the local authorities. This project aims to standardise one of the decisions designers have to make. The design fire is fundamental in the design of the fire safety system in a building. By standardising them there are a number of benefits to the NZ building industry:

### Wealth Creation

The introduction of standardised design fires will improve the design and approval process of fire safety designs. It will simplify the review process, increase efficiency and consequently reduce the design costs. It will also better facilitate the introduction of new products that will reduce the cost of protection without reducing the level of safety provided to the occupants in residential buildings.

### Environmental and Social Returns

The use of a set of design fire specifications that are generally accepted by industry will lead to greater confidence that fire engineering designs are based on appropriate and consistent assumptions regarding fire scenarios, fire sizes and characteristics of combustion products. This will ensure that individual and society expectations regarding the levels of fire safety provided in residential buildings are more likely to be achieved in practice.

### Users' capacity to apply outputs

Results will be presented in a format that allows easy use by fire design engineers and approving authorities in Australia and New Zealand as well as in other countries.

## **1.2 Background**

### **1.2.1 Key Definitions**

The following definitions are of particular importance to the scope of this project. The following definitions are from ISO TC92 SC4 (ISO (2003):

“Design Fire” – A quantitative description of assumed fire characteristics within a Design Fire Scenario. Typically, an idealised description of the variation with time of important fire variables such as heat release rate and toxic species yields, along with other important input data for modelling such as the fire load density.

“Fire Scenarios” – A specific fire scenario on which a deterministic fire safety engineering analysis will be conducted. As the number of possible fire scenarios can be very large, it is necessary to select the most important scenarios (the design fire scenarios) for analysis. The selection of design fire scenarios is tailored to the fire-safety design objectives, and accounts for the likelihood and consequences of potential scenarios.

“Design Fire Scenario” – A specific fire scenario on which a deterministic fire safety engineering analysis will be conducted. As the number of possible fire scenarios can be very large, it is necessary to select the most important scenarios (the design fire scenarios) for analysis. The selection of design fire scenarios is tailored to the fire-safety design objectives, and accounts for the likelihood and consequences of potential scenarios.

This thesis looks at design fires, as defined above, only. Fire scenarios and design fire scenarios have, however, been taken into consideration when defining the scope of this thesis.

### **1.2.2 Residential Fire Statistics**

Residential fires have been identified, in many countries, as the location where fires occur most often and the greatest number of fire fatalities occurs, as shown in recent Australian and New Zealand fire statistics (NSWFB (2003; NZFS (2004). Figure 1-1 and Figure 1-2 below shows statistics extracted from NZFS (2004) for 1999 – 2003.

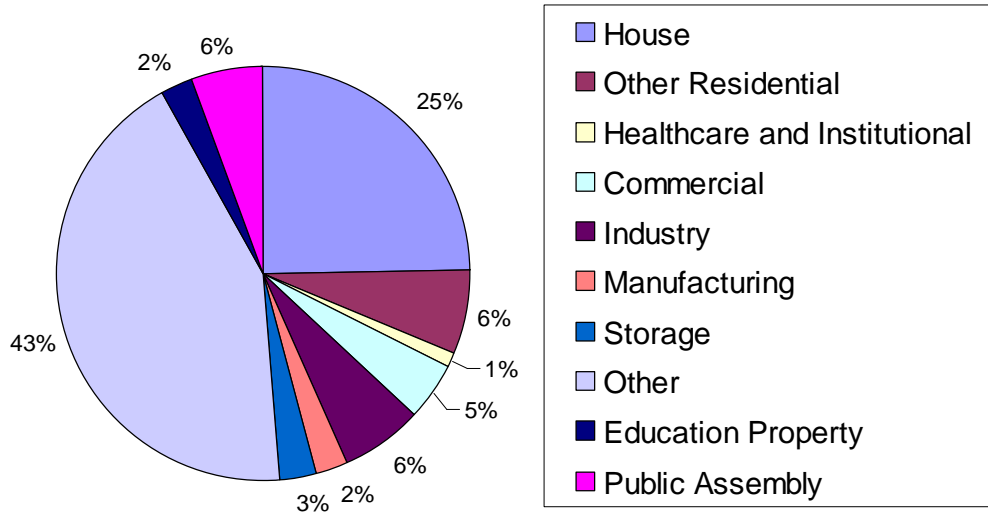

Figure 1-1: Location of Fires in New Zealand 1999 - 2003, Extracted from NZFS (2004)

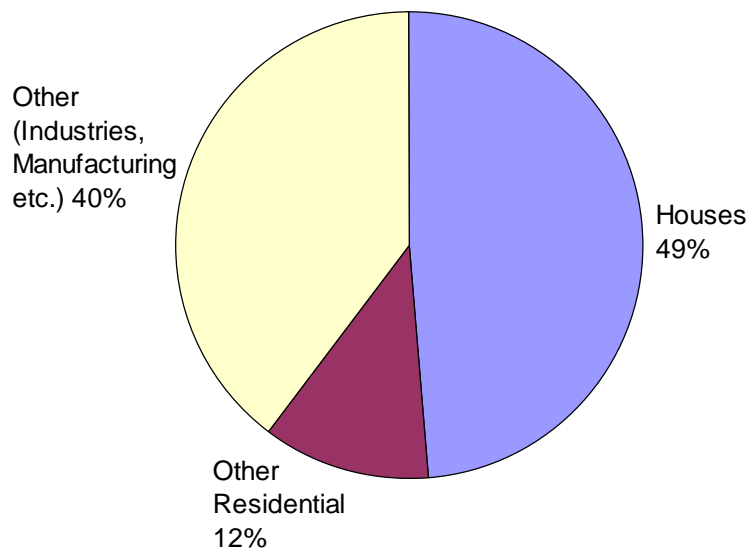

Figure 1-2: Location of Fire Fatalities in New Zealand 1999 - 2003, Extracted from NZFS (2004)

In Figure 1-1 the houses and other residential properties accounts for 31% of the fires. The highest location for fires was the 'other' category, which includes rubbish bins, cars and other places which are not buildings. The fatalities that occurred due to fire 61% occurred in houses and other residential buildings (Figure 1-2). The 'other' category in Figure 1-2 also includes car fires and other locations not in buildings. Additional fire statistics illustrating the prominence of house/ residential fires and the highest proportion of fatalities compared to fires in other locations can be seen in Apte et al. (2005). Fire statistics identify cooking fires as the most common source of fire, however fires involving upholstered furniture appear to be involved in more fatalities making them more hazardous (Apte et al. , 2005).

The fire statistics show more can be done to reduce the number of fires in residential building and reduce the number of fatalities caused by these fires. The first step is to identify the types of fires occurring and the characteristics of these fires. Then consider methods to either prevent the fires from occurring or actions which can mitigate the effects of a fire. This thesis identifies the types of fires and the fire characteristics for use in designing fire safety systems, mitigating the effects of a fire. As fire statistics show the highest number of fatalities in residential fires occur in lounges and bedrooms and involve soft furnishings and bedding (Apte et al., 2005). For this reason upholstered furniture fires and bed and bedding fires are studied in detail in this thesis.

### **1.2.3 Design Fires**

Within the fire field the terms *design fire* and *design fire scenarios* are widely used. There are a number of different interpretations of what a design fire should be and what the design fire should describe, that is the properties that should be specified. According to the International Fire Engineering Guidelines (IFEG, 2005) "a design fire is used as a basis for assessing fire safety systems". The fire characteristics of interest ultimately depend on which part of the fire safety system is being assessed. Most commonly a design fire is defined by the heat output, which is the Heat Release Rate (HRR measured in kW), with respect to time. However other conditions created by a fire often need assessing, for example impaired visibility caused by smoke and levels of toxic gases in the room of fire origin and in adjoining rooms.

There are a number of sources which give qualitative guidelines to choosing/ creating design fire scenarios and design fires. Key references are ISO (2003), Hertzberg et al. (2003), Buchanan (2001), NFPA (2003). In the end it is at the discretion of the engineer to identify fire scenarios and to choose how many design fire scenarios they will evaluate and what design fires they will use.

All these references recognise the importance of identifying the realistic worst case scenarios and the dangers of underestimating the size of a design fire in the design phase. Design fires need to consider the effects of the following variables:

- The fuel characteristics ignitability, geometry, arrangement etc.
- Ventilation
- Geometry of the enclosure

The references identify these variables and possible positive and negative effects on the fire characteristics; however they do not offer quantitative solutions to incorporate these effects into the design fire.

The design fire is defined as four separate phases: ignition, growth, full development and decay. Hurley & Quire (2003) states "As there is not a single framework for developing the entire design fire curve, each step is typically developed separately and then brought together as a single curve." It is

recognised that it is not always necessary to quantify all stages of a fire, depending on the goal of the analysis. For example;

- Life safety – the growth phase is the most important.
- Smoke control – maximum smoke production rates.
- Structural analysis – peak HRR and fire duration.

A common broad brush approach to a design fire is;

- Ignition phase ignored
- Growth phase is commonly defined as a  $t^2$  – fire, which has been defined in Equation 1 and Equation 2

$$Q = Q_0 \left( \frac{t}{t_g} \right)^2$$

Equation 1

Where: Q Heat Release Rate [MW]  
t time [s]  
 $Q_0$  usually 1 MW  
 $t_g$  growth time, time it takes the fire to reach 1.055 MW [s]  
600, 300, 150 and 75, represent slow, medium, fast and ultra fast growth rates respectively

The above equation can also be expressed:

$$Q = g_q \alpha t^2$$

Equation 2

Where: Q Heat Release Rate [MW]  
t time [s]  
 $\alpha$   $1/t_g^2$  fire intensity coefficient [MW/s<sup>2</sup>]  
0.003 kW/s<sup>2</sup>, 0.012 kW/s<sup>2</sup>, 0.047 kW/s<sup>2</sup>, 0.19 kW/s<sup>2</sup>, represent slow, medium, fast and ultra fast growth rates respectively  
 $g_q$  partial coefficient, though there are no recommendations on how to use this parameter

- Fully developed phase is then defined as a maximum HRR bounded by the fuel or flashover
- Fire duration determined by the total fuel load
- Decay phase ignored



Various outputs can be used to define a design fire, the most important being the HRR profile, and depending on the application the following may also be relevant:

- Smoke production rates
- Soot yield
- Species production rates
- Temperature profiles
- Visibility
- Heat fluxes
- Mass loss rate of the fuel
- Flame spread

A number of methods of developing design fires are also suggested, including:

- Hand calculations
- Simple spread sheets
- Experimental data
- 'Expert' opinion, previous knowledge/ experience
- Computer modelling – 2 zone models, CFD

Or a combination of methods, each method has a number of limitations in their application. It is currently the responsibility of the practising engineer to identify and work within any limitations. Suitability of a method depends on the fire safety objectives and the interpretation of results from the engineer.

### ***1.3 Objectives of this Report***

A design fire is a quantitative description of a fire that is representative of a particular scenario or sequence of events. The description is given in terms of the heat release rate history, production rates of various products, and various combustion parameters as well as the probability of the event. Typically, this would form the basic input to a fire model describing a fire scenario, with the fire engineer deciding on the appropriate design variables and parameters to be used on any particular project. ISO standards provide general guidelines for design fires and scenarios, but do not recommend design fires for specific occupancies or scenarios, thus justifying the need for this project.

The objectives of this project are two fold:

1. To begin the development of a credible set of design fires for furniture in apartment/residential buildings that will be acceptable for use by fire engineers and approving authorities.
2. To provide a methodology to incorporate the compartment effects, specifically the radiation enhancement and the impact of the ventilation rate, on the heat release rate history, species production rates, and other combustion parameters required in the design fire definition.

## **1.4 Methodology / Project Overview**

The methodology and the design fires are based on experimental data from the literature and computer modelling.

Chapters 2 – 5: Reviews the available literature relating to furniture fires and compartment fires. Each chapter is divided into two sections; the first section is an annotation of literature reviewed with the intent of providing a comprehensive reference. The second section is a summary of the main parameters and fire characteristics. Chapter 2 reviews literature on Beds and Bedding Assemblies; Chapter 3 reviews Upholstered Furniture Fires; Chapter 4 reviews Compartment Effects. Chapter 5 reviews the main findings from the literature review and summaries the characteristics of interest.

Chapter 6: Collates the available experimental fire data, determines the quality of the data and the documentation available. Creates a database and identifies how much data is available for burning characteristics of interest for representative fuels including the compartment effects. The fire characteristics of interest include heat release rate, fire growth rate, fire duration, mass burning rate, surface flame spread, heat of combustion, species production rates and soot, etc. Chapter 5 also identifies gaps in the available data.

Chapter 7: Uses the values obtained to recommended input values to fire growth models. Where there was sufficient data the burning characteristics were statistically analysed. These were; growth rate, peak HRR, time to peak HRR and Total Heat Released. Free burn / room burn experimental pairs were analysed to determine the compartment effects looking at the same parameters – growth rate, peak HRR, time to peak HRR and Total Heat Released and in addition heat of combustion and maximum CO/CO<sub>2</sub> ratio. The analysis was used to justify design fire parameter decisions and incorporate compartment effects.

Chapter 8: Looks at modelling upholstered furniture items in FDS and verified the simulations with the data collected. The chapter is divided into two sections; the first section outlines the four series of simulations and the second section presents the results and discussion for each series. Series 1 was a preliminary study using FDS default values and approximate furniture geometries in free burn conditions. In Series 2 the material properties were changed in free burn conditions. Series 3 modelled compartment fires. In Series 4 a sensitivity analysis was conducted.

Chapter 9: Concludes the thesis; Specifies the preliminary design fire parameters and design methodology, and identifies future work including filling gaps in data.

## 2 Literature Review – Characteristics of Bed and Bedding Fires

There are a number of standard tests and regulations regarding mattresses, beds and bedding assemblies. These include full-scale, reduced-scale and cone calorimeter tests. Some consider the mattress in isolation, while others consider the effects of bedding on the burning behaviour of the assembly. Simply testing the mattresses in isolation is not realistic for design fires in residential buildings, since mattresses are not usually found in isolation. Research, for example Rieber (1983) and Ingham & Edwards (1984), has found that, while mattresses can have good fire resistance, the bedding can have a significant effect on the burning behaviour.

### 2.1 Literature Annotation

#### 2.1.1 Full Scale Bedding Assemblies

For a realistic fire test the UK Crown Supplier specifications for bedding recognise the importance of disturbing or pulling back the covers (Krasny et al. (2001). A tightly made bed will have slower flame spread than a loosely made or unmade bed. The testing of bedding assemblies typically involves a made bed with the covers folded back in one of the top corners, exposing the sheets, as shown in Figure 2-1. Unless otherwise stated, this is the configuration of the bedding assembly tests discussed below.

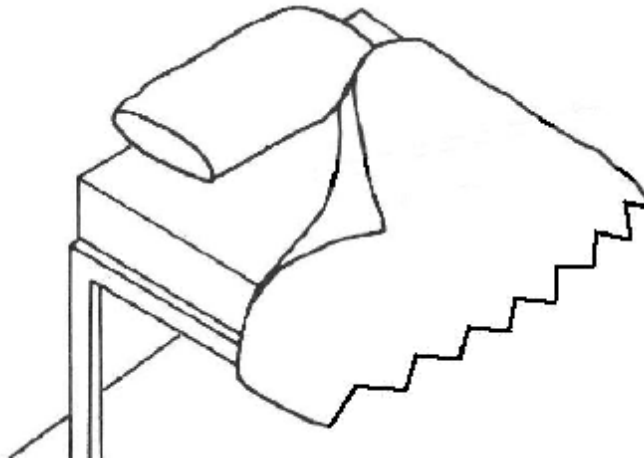

Figure 2-1: Bedding assembly configuration for fire testing. Adapted from Benisek et al. (1985).

### Woolley et al. (1976)

Some of the earlier research was performed by Woolley et al. (1976) to establish the burning characteristics of beds made up with common bedding materials. The tests were conducted in a room-corridor configuration (see Figure 2-2). The room was 3.0 m x 2.0 m adjoining a corridor 1.3 m wide and 12.6 m long, the complete setup was 2.4 m high. Room temperatures, smoke production and radiation were measured within the room, and temperature and smoke measurements were taken at the end of the corridor. The HRR was not measured in this series of experiments; therefore the ceiling temperature above the bed in the test room has been used in the discussion of results. The maximum test duration was 30 minutes.

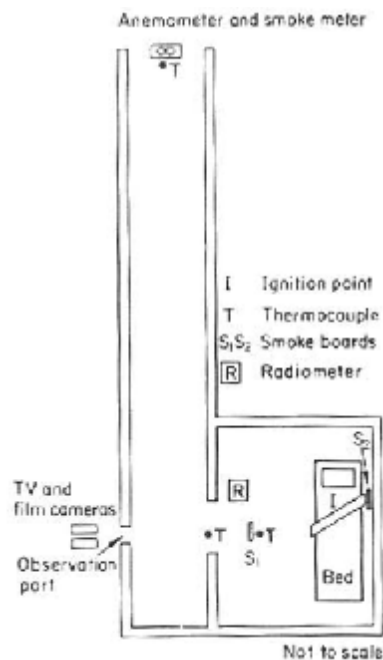

Figure 2-2: Room-corridor configuration. Extracted from Woolley et al. (1976).

Single beds were used in the bedding assembly, which was made up of a mattress, mattress cover and bedding. The mattresses were placed on a metal spring base with a laminated chipboard headboard, which was placed against the wall. Typically the mattress size was 1.91 m x 0.92 m and the depth varied from 0.10 m – 0.15 m. The mattresses fillings were hair, spring interior, and a number of different foam rubbers and polyurethane foams. The mattress covers were cotton, fire retardant cotton or proofed nylon (nylon treated with polyurethane varnish to water proof the cover). Two interliners were also investigated: hair and glass fibre. The bedding consisted of two feather pillows with cotton covers and cases, two cotton sheets, cotton or wool blanket and cotton bedspread.

The ignition source was crumpled newsprint with an embedded electrical element. Two ignition locations were used: on top of the bed (beneath the sheets, in the crease of the folded back covers, as

shown in Figure 2-1) and underneath the bed. Preliminary experiments used a single double sheet (25 g) of newspaper, however the main test series used four double sheets of newspaper crumpled into a ball (100 g).

The bedding assembly with the standard polyurethane mattress and cotton cover was considered the control configuration. This compartment reached a maximum temperature 230°C in 7 minutes. The tests found the larger ignition source on top of the bed was more likely to create rapidly burning fires involving the whole bed. In comparison, the small ignition source underneath the bed was found to possibly lead to a delayed, but more severe fire. This was attributed to the bedding materials being allowed to preheat prior to flaming combustion. Since the top ignition source was located on the unmade part of the bed, there was negligible difference between the fire behaviour when a wool blanket was tested and when a cotton blanket was tested.

The results from this series of experiments showed the hair and spring interior had slow fire development compared to some of the foam rubber and polyurethane mattresses, which produced rapid fire growth. The commercial polyurethane foam mattress and cold cured polyurethane mattress had similar fire behaviour characteristics to the standard polyurethane foam mattresses. The fire retardant cotton covers increased the time before maximum involvement of the bedding assembly, but did not significantly change the maximum temperature reached for most assemblies tested. The proofed nylon cover had the worst fire performance, reaching the highest maximum temperature of 550°C in 7 minutes. The combination of a glass fibre interliner and the control assembly (standard polyurethane mattress and cotton cover), with a fire retardant cover, improved the fire performance significantly. The time to maximum involvement was delayed, to 26 minutes 30 s after ignition; however the maximum temperature was 285°C, a slight increase. The results using the hair interliner showed even better fire performance (21 minutes, 80°C). However it was suggested that the increased risk of smouldering combustion and its associated dangers needed to be investigated in this case.

Two fire retardant treatments were applied to the standard polyurethane mattress. Both of these treatments significantly improved the fire performance. Results for the first fire retardant treatment (of which the details were not specified) showed full involvement of the mattress occurred 27 minutes after the test was initiated (and reached a maximum temperature of 280°C). The addition of a fire retardant cover further limited the maximum temperature to 65°C. Accelerated aging was applied to the mattresses, which had a negative impact on the fire performance of the first fire retardant mattress, with a higher maximum temperature reached earlier (325°C, at 13 minutes). The combination of the fire retardant mattress and cover produced significant quantities of smoke. The second fire retardant treatment was a standard polyurethane mattress coated with a thick layer of semi-rigid fire retardant paint, with a fire retardant cover. The maximum temperature reached was 57°C, which was reached at 22 minutes after ignition. However no tests were conducted to investigate the effects of aging.

None of the beds tested would cause room flashover in isolation, except possibly the bedding assembly with the standard polyurethane mattress with proofed nylon cover. However the thermal radiation may be sufficient to spontaneously ignite other objects in the room, causing flashover. Visibility was calculated using the smoke production measurements. Results showed that only the foam rubber moulded slab mattress with fire retardant cotton cover produced enough smoke to reduce visibility to less than 1.0 m (which occurred at 13 minutes). Other bedding assemblies that reduced visibility to 2.0 m during the 30 minute tests were: fire retardant polyurethane foam mattress with cotton cover (at 25.8 minutes) and the aged fire retardant polyurethane foam mattress with cotton cover (at 14 minutes).

### **Ingham and Edwards (1984)**

Ingham & Edwards (1984) focused on bed and bedding assemblies available in New Zealand in the 1980's. They investigated the use of wool products (ticking, overlay, blankets and duvet filling) to reduce the risk of ignition and the fire growth of polyurethane mattresses. Half-sized bed assemblies were used in the experiments. The mattress was, in most cases, a polyurethane foam mattress with a cotton or fire retardant wool cover (900 mm × 750 mm × 100 mm). A wool-filled mattress with cotton cover (900 mm × 914 mm × 122 mm) was also tested to compare the fire risks. The bedding consisted of commercially-available 50/50 polyester/cotton sheets, a blanket (made from acrylic, wool or cotton) or a duvet (with polyester fill with a polyester cotton cover or wool fill with cotton cover), and in some cases a mattress overlay (a wool blanket, fire retardant wool blanket, wool-pile (Woolrest™), wool-filled with cotton cover). The frame was an iron framed, metal based hospital bed.

The ignition source was a butane-gas flame, used to simulate a match flame. Three different sized flames were used (in accordance with BS 5852:1979 Part 1 and 2). The flame heights and the corresponding application times were 36 mm for 20 s, 150 mm for 40 s, and 245 mm for 70 s. The tip of the burner tube was placed 40 mm from the crease of the folded covers, where the sheets were exposed.

The rate of flame spread and fire intensity was reduced with the use of a wool blanket or duvet, compared to the other bedding tested. A wool overlay prevented ignition from the small ignition source, and limited the fire spread and intensity for the larger ignition sources. Wool-filled mattresses provided the best protection, only suffering surface charring even when the bedding burnt. The test results also showed that the speed of flame spread ranking from very fast to very slow for the various duvet and blankets was acrylic blankets, polyester filled duvet, cotton blanket, wool filled duvet, then wool blanket.

### **Paul (1989)**

Paul (1989) investigated the burning behaviour of bed assemblies, with reduced flammability for use in hospitals, using a room-corridor arrangement, as shown in Figure 2-3. Temperature, smoke volume

and density, gas concentrations (CO, CO<sub>2</sub> and O<sub>2</sub>) and mass loss rate were measured during the tests. The HRR was estimated from the mass loss rate resulting in very approximate HRR profiles.

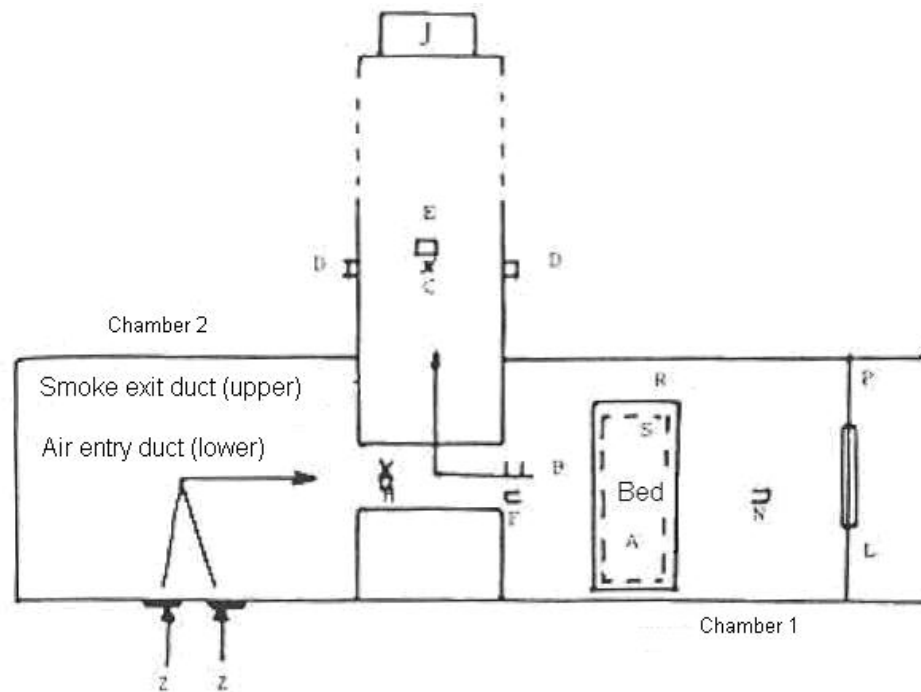

Figure 2-3: Room-corridor arrangement used in the experiments. Extracted from Paul (1989).

Two different bed bases were tested: a solid metal base or a wire mesh base. Mattresses were made of standard hospital contract foam or polyurethane barrier foam. The bedding consisted of three pillows (made from polyurethane foam, with a fire retardant cotton cover and polyester pillow case), two polyester sheets, a blanket and a bedspread (made from fire retardant cotton, modacrylic or polyester). A limited number of tests were conducted using untreated cotton bedding on barrier foam mattresses.

A no. 7 crib was used to ignite the bedding. Two ignition locations were used, one at the crease of the covers and the other against the pillows, as shown in Figure 2-4.

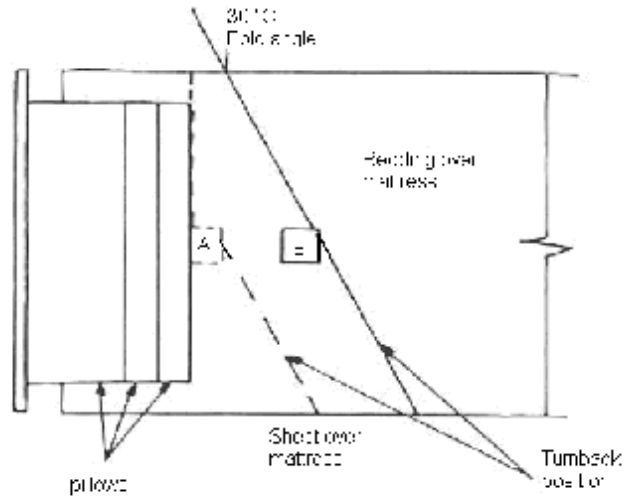

Figure 2-4: Location of ignition sources. Extracted from Paul (1989).

The results from these tests showed that the wire bed base produced a more severe fire than the solid bed base, if the mattress melted or disintegrated during the test. The severity of the bed assembly fire was dependent on the type of mattress tested. The polyester bedding produced more smoke and fire gases than the other types of bedding. The polyester bedding also was observed to burn with a small flame.

The modacrylic and fire retardant cotton burned with similar characteristics. Flame spread over the bed assembly by way of the sheets and pillowcases. Fire spread more extensively and steadily with the untreated cotton bedding on the barrier foam mattress than the other tests with the barrier mattress. The bed assembly also produced a highly irritant, light grey smoke.

While the pillowcase burned, the fire retardant case around the pillow filling formed a char layer. When the char layer broke, the pillows burned rapidly and significantly contributed to the production of heat and smoke. The total bedding assembly had a significant effect on the burning behaviour, especially when the ignition source was remote from the pillows. When the fire was able to spread to the pillows and ignite them, the heat released and the smoke produced was considerably increased. This was attributed to the combustible mass of the pillows and the ability of the heat released to ignite other components.

## 2.1.2 Full Scale Mattresses Excluding Bedding

### Paul (1980)

Paul (1980) investigated beds and upholstered furniture to address the, then current, concern that upholstered furniture was relatively easy to ignite and had rapid burning behaviour. Bedding was



excluded from these experiments, because it was considered beyond the control of the manufacturer. Temperature and smoke density were measured. The primary objective of this paper was to evaluate the ability of scale mock-ups to simulate full-scale burning behaviour. Conclusions, based on the test results, suggested that the half-scale mock-ups simulated full-scale items reasonably well, however smaller-scale model results deviated significantly from the full-scale results.

### **CBUF Study**

The Combustion Behaviour of Upholstered Furniture (CBUF) study edited by Sundström (1994) looked at mattresses in isolation, since the focus was on the manufacturing requirements of upholstered furniture and the manufacturer has no control over the bedding used on mattresses. Mattresses were tested on a slat mock-up bed. The CBUF database contains furniture calorimeter data and room burn data for 6 commercially available mattresses (solid foam and inner spring, ranging from domestic foam to foams containing fire retardant) and two mock-up mattresses (solid foam and inner spring). The results of the study were that solid foam mattresses showed flame propagation and significant burn out. Whereas inner spring mattresses did not propagate flames, but smouldered and self extinguished.

### **Luo and Beck (1996)**

Luo & Beck (1996) conducted a multi-room test with a mattress (polyurethane foam slab) fire to compare experimental results with Computational Fluid Dynamics (CFD) models. The set up can be seen below, in Figure 2-5. Quantities measured were temperature, radiation, gas composition, smoke optical density and soot concentration, CO, CO<sub>2</sub>, and O<sub>2</sub> concentrations in both the room of origin and at the remote locations.

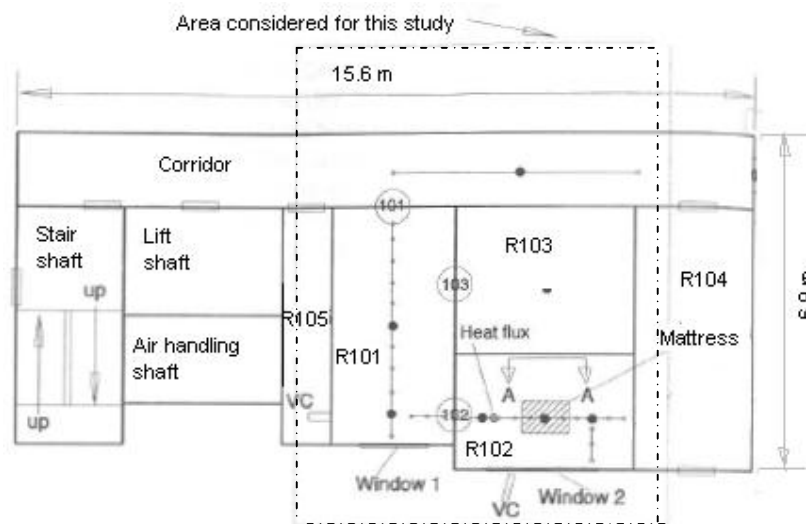

Figure 2-5: Multi-room arrangement used for mattress fire testing. Extracted from Luo & Beck (1996).

Two fuel loads were used in the experimental part of the study. The smaller load was a polyurethane foam slab (0.95 m × 0.94 m × 0.15 m) equivalent to half a mattress. The larger load was three polyurethane foam full-sized single mattresses (two were 1.88 m × 0.95 m × 0.15 m and the other was 1.88 m × 0.95 m × 0.1 m). The fuel configuration is shown in Figure 2-6. In both cases, the base was a steel frame with the mattresses supported by a steel mesh. An electrical igniter, set at 800°C, was used to initiate combustion of the mattress.

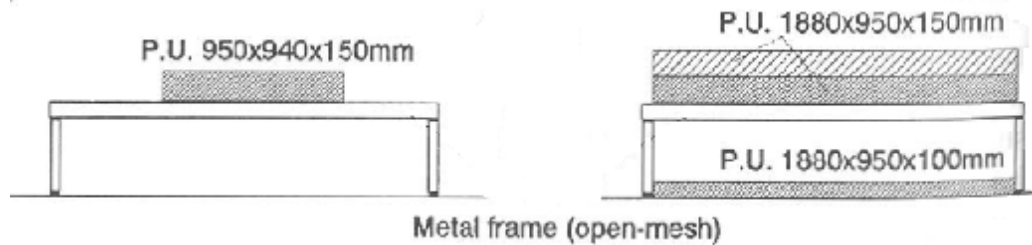

Figure 2-6: Fuel configuration used. Extracted from Luo & Beck (1996).

The fire associated with the smaller fuel load developed slowly and lasted approximately 7 minutes. The temperatures within the burn room reached 500°C at 1.9 m around 4 minutes after ignition. The temperature reached approximately 200°C in adjacent rooms and 100°C in the hallway. The concentration of O<sub>2</sub> decreased to 12 vol% in the burn room and to 17 vol% in the corridor. The concentration of CO<sub>2</sub> increased to 3 – 6 vol% and CO concentrations increased to 0.35 vol% in the burn room.

The larger fuel load, designed to cause flashover in the burn room, burned slowly for the first 3 minutes, with rapid fire growth leading to flashover in the 4<sup>th</sup> minute. The duration of the fire was similar to the smaller fuel load (7 minutes). The window present in the burn room cracked at 3.5 minutes and fell out before flashover at 4.5 minutes. In the burn room, the temperatures exceeded 900°C at 1.9 m. Temperatures reached between 400°C and 700°C in the adjacent room and 200°C in the corridor, at approximately 4.5 minutes after ignition. The O<sub>2</sub> concentration dropped to < 5 vol% in the burn room and 10 vol% in the adjacent room. Concentration of CO<sub>2</sub> increased to 10 vol% and 7.5 vol%, as did the CO concentrations to 3 vol% and 1 vol%, in the burn room and adjacent room, respectively.

These results showed the significant changes in conditions with increasing fire load, with untenable condition developing in rooms adjacent to the room of origin. Both fires had a similar duration, providing some indication of possible radiation feedback effects for bed assemblies and the level of combustion products produced by polyurethane foam mattresses. Luo & Beck (1996) also presented CFD results that showed this scenario successfully simulated in the CESARE-CFD model by using a solid fuel and predicted the mass loss rate and the HRR.



- The innerspring mattresses had similar results to the non-innerspring mattresses. Two mattresses failed because they reached flashover conditions before 10 minutes. These were the non-fire retardant polyurethane foam and low density foam, which complied with TB 117.

### **Babrauskas (2002)**

Babrauskas, V. (2002), in the SFPE Handbook, summarised research on mattresses, excluding bedding. Babrauskas noted that the burning behaviour of polyurethane mattresses is very sensitive to the surrounding environment. This is due to the fuel acting like a liquid pool once the polyurethane foam melts. This behaviour can be enhanced or reduced depending on the type of bedding used in a bedding assembly. The effect would be enhanced if the bedding propagated the fire, further increasing the liquid pool. On the other hand, preventing ignition of the mattress can reduce the pool fire effect.

## **2.1.3 Comparing Mattress and Full Bedding Assembly Fires**

### **Damant and Nurbakhsh (1992)**

The results of a comprehensive study on the burning behaviour of full scale mattresses and bedding assemblies were published by Damant & Nurbakhsh (1992). Approximately 40 full-scale tests were conducted in 1991 in a *Bureau of Home Furnishings and Thermal Insulation* (BHFTI) fire facility test room (3.05 m × 3.66 m × 2.44 m). The room had an open doorway (0.97 m × 2.06 m). During the tests, the temperature, gas concentrations (for O<sub>2</sub>, CO and CO<sub>2</sub>), smoke opacity, mass loss of the bed and HRR were measured and recorded. Four series of test were conducted:

- Control tests, using standard bedding components over an inert fibre glass mattress, with ignition by burner only.
- Mattresses in isolation. (The author of this review was not able to verify this, but it has been assumed the mattress was on an inert frame.)
- Mattresses on a box spring base.
- Full bedding assemblies with mattress, base and bedding components.

The bedding components tested comprised of 50/50 polyester/cotton sheets and pillowcases, a pillow (either 100% loose polyester fibre filling or 100% cotton ticking), and a 100% acrylic blanket. The mattresses tested had innersprings or solid foam cores, the foams can be characterised into five different groups, these were:

- Standard polyurethane foam,
- TB 117 fire retardant polyurethane foam,
- Melamine treated polyurethane foam (highly ignition resistant),
- Neoprene or polychloroprene foam, or
- Other fire retardant foam.

The ignition source for these tests was a T-shaped propane gas burner positioned parallel to the bottom horizontal surface of the mattress (1 inch from the vertical side panel). The burner was applied for 3 minutes. The general observations were recorded for the tests, as well as the maximum HRR, temperatures and CO concentrations. However it appears the corresponding times were not published.

A number of general conclusions were made; those relevant to this literature review have being summarised as:

- The burning behaviour of a mattress was largely dependant on its combination of filling material, style and construction.
- Overall, different cover fabrics did not alter the burning behaviour significantly, unless the fabric was treated with a fire retardant.
- A fire retardant ticking was effective in improving the fire performance and some non-fire retardant tickings were also capable of slowing the rate of burning and delaying the fire spread to rest of the bedding assembly.
- Mattresses containing neoprene and chloroprene foam had very good fire performance, even when used in combination with cotton batting, which has no fire resistance. However when properly treated with boric acid, cotton batting performed well as a fire block component.
- Flaming combustion usually ceased once the burner was removed, but the development of smouldering combustion was common and this fire hazard needs to be considered.
- The combination of materials used in mattresses needs to be considered carefully. As the tests found, if one component was a fire barrier or a fire blocking material good fire performance was still obtained even though other materials were not fire retardant. Conversely, positive effects of fire retardant components could be neutralised when used in combination with other components.
- When evaluating the fire hazard, the study found mattresses and bedding assemblies containing standard polyurethane foam contained enough fuel to rapidly lead to flashover. It was also noted that replacing standard polyurethane foam with foams which complied with TB 117 did not necessarily improve the fire performance.
- The bedding contributed significantly to the fuel load of the bedding assembly, however their overall effect was dependant on the nature of the other components used.

- The effect of different types of bases was also dependant on the components in the bedding assembly.
- The fuel load of a mattress in isolation was concluded to be insufficient to determine the fire performance of a bedding assembly.

### Ohlemiller et al. (2000 – 2003)

Ohlemiller performed extensive research into beds, bedding and mattresses (Ohlemiller & Gann (2003); Ohlemiller & Gann (2002); Ohlemiller (2003); Ohlemiller et al. (2000). Ohlemiller's series of reports systematically investigated the burning characteristics of bedding assemblies. Figure 2-8 shows the mattress and foundation structure used in all tests discussed by Ohlemiller, unless otherwise stated.

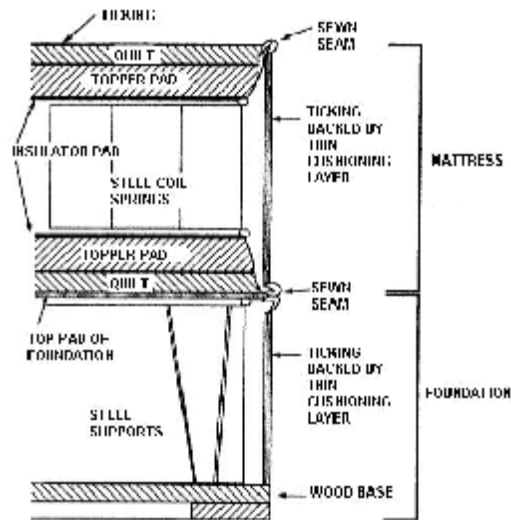

Figure 2-8: Schematic of the cross-sectional view of the mattress and foundation structure. (Ohlemiller & Gann (2003); Ohlemiller & Gann (2002); Ohlemiller (2003); Ohlemiller et al. (2000).

Ohlemiller et al. (2000) looked specifically at the bedding and the simulation of the burning bedding using gas burners. Ohlemiller & Gann (2002) also tested mattresses with varying burning characteristics (from low to high HRR), to estimate the resulting fire risks associated with each type of mattress. Ohlemiller & Gann (2003) also investigated the burn characteristics of different types and combinations of bedding possible on bedding assemblies. The effect of these modifications on the characteristics of the whole bedding assembly was then assessed. Ohlemiller (2003) then compared the results with the burning behaviour of bedding assemblies where gas burners simulating a bedding fire were used (Ohlemiller et al. (2000).

Ohlemiller et al. (2000) investigated the thermal impact on mattresses created by burning bedding in order to produce a reproducible simulation. Twelve different bedding sets were tested on inert

mattresses in a furniture calorimeter. HRR, flame spread and heat flux data was measured and recorded. Using an infrared imaging technique, six sets were further characterised by the heat flux patterns they imposed on the mattress. Propane burners were then used to simulate the burning bedding in terms of peak heat flux, duration and area. From these results, a series of tests were conducted comparing bedding assemblies, mattress, base and bedding, and mattress and base sets with the propane burners.

The bedding ranged from two sheets and a pillow only, to a mattress pad, two sheets, a blanket, a heavy bedspread and a pillow. The materials of the bedding were:

- Sheets: polyester/cotton or cotton.
- Pillows: polyester fibrefill or latex foam.
- Blankets: acrylic, polyester, polyurethane, cotton or wool.
- Bedspreads: polyester fibrefill of medium weight or heavy weight.

The bedding was ignited using a gas burner simulating a match flame. The arrangement for the inert tests is shown in Figure 2-9.

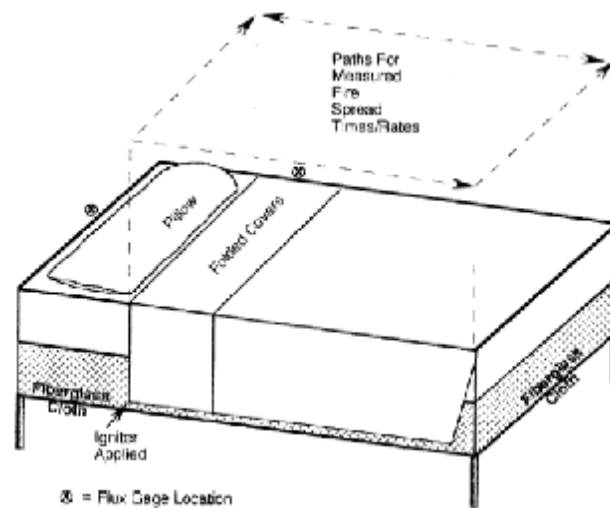

Figure 2-9: Schematic of the set up and igniter position for bedding tests on inert mattresses. Extracted from Ohlemiller et al. (2000).

The maximum peak HRR reported from the twelve combinations tested was 200 kW and the minimum was 130 W. Even though 130 W was relatively small, it was still a significant increase of heat released compared to the initial ignition source, increasing the risk of the mattress igniting. For a small room, it was assumed that flashover would occur at 1.1 MW (Ohlemiller et al. (2000)). In isolation, the bedding combinations tested produced insufficient heat to cause flashover. To prevent flashover in a room, the

heat released by the mattress would need to remain under 900 kW without other items in the room igniting.

The data was selected from six combinations of bedding burn tests to characterise the bedding using propane burners (which produced a heat flux on the top and side of the mattress). Peak HRR rates, time to peak HRR, average rate of flame spread and incident heat flux were given for each bedding combination, as well as the HRR curve for one of the bedding combinations.

Five types of twin bed sized mattresses were tested: one representing commercially available residential mattress and four experimental reduced-flammability designs. The mattresses were also tested using the heat flux produced by the propane burners and with one of the bedding sets. The propane burners simulated the burning bedding well in four out of the five mattresses. However a phenomenon described as internal over-pressurisation (Ohlemiller et al. (2000) occurred in the 5<sup>th</sup> mattress with the bedding. The heating of the mattress surface produced a flammable gas mixture within the mattress. This caused the seams to rupture, which allowed the fire to penetrate the interior of the mattress. The characteristics of the over-pressurisation were not well simulated by the propane burners.

The mattresses were improved as follows:

- Mattress 2 employed more flame resistant ticking and moderately flame retardant foam.
- Mattress 3 contained a ticking with a fire barrier material.
- Mattress 4 contained flame retardant polyester batting instead of polyurethane foam.
- Mattress 5 combines flame retardant foam with boric acid treated cotton batting.

A description of each of the mattress tests is given in the report comparing the residential mattress (Mattress 1) with the four altered mattresses. The difference between the five mattresses varied from delayed/slowed fire growth, with equal severity to appreciably reducing the HRR, but still consuming the mattress and base, to reducing the HRR by limiting the mattress involvement.

Ohlemiller & Gann (2002) attempted to quantify the change in fire risk resulting from the change in fire intensity of a bedding assembly fire. Free burn and room tests were conducted for the different types of mattress, while the bedding remained constant. The free burn tests measured the HRR and mass loss rate. Radiant heat flux and flame length/reach were also measured to assess whether a remote object could ignite. The room tests were instrumented with heat flux gauges and thermocouple trees. CO concentrations were estimated using CFAST. Flashover was assumed to occur when the HRR exceeded 1 MW in a normal sized bedroom.

King and twin sized beds, with three different constructions, were tested: one replicating the design most common in residential buildings with a relatively high HRR, and two experimental designs with



intermediate and low HRRs. Bedding consisted of a polyester/cotton mattress pad (which covered the top and sides), a fitted and flat 50/50 polyester/cotton sheet, an acrylic blanket, a polyester fibre fill bedspread, and polyester pillows in polyester/cotton cases (one for the twin bed and two for the king sized bed). The ignition source and location was the same as used previously (Ohlemiller et al. (2000).

The relationships between the peak HRRs achieved with the king sized beds and the twin beds appeared to be based on the mattress designs. For the residential mattress, there was a large effect on the peak HRR due to the bed size. The intermediate HRR mattress did not show an obvious effect due to the bed size. However the room tests accentuated the differences in peak HRR and other burning characteristics between the different bed sizes. The king sized beds generated a more severe fire due to the increase in fuel. The two experimental mattresses often had two peaks in the HRR profile, for both the open hood and room tests. Table 2-1 shows the results of one of the tests of the king sized beds.

Table 2-1 Results from the king sized bedding assembly tests. Adapted from Ohlemiller & Gann (2002).

Mattress / Foundation Design	Test Location	Peak HRR <sup>a</sup> (kW/m <sup>2</sup> )	Time from Ignition to Peak <sup>a</sup> (s)
Low design	Open hood	290	380
Intermediate design	Open hood	755 (660)	700 (1160)
Regular (high) design	Open hood	3850	305
Low design	Room	420	525
Intermediate design	Room	880 (955)	445 (970)
Regular (high) design	Room	4620	334

<sup>a</sup> Numbers in parentheses are associated with the second peaks.

Smouldering combustion then occurred in the bedding assembly with the mattress designed to have a low HRR. Flaming combustion spontaneously resumed 4 minutes after the initial peak. This behaviour was not investigated in this report, and the fire was extinguished.

From these experiments and previous experiments (Ohlemiller et al. (2000) it was clear that a room containing a bed with a regular mattress would be at high risk of flashing over. The bed fire was severe enough to cause flashover, even before secondary items were considered. The focus of this report was to determine the risk of flashover, if the experimental mattresses were in a room fire. The intermediate mattress also showed a high risk of room flashover, when the bed was burned in isolation. When the bedding assembly with the low mattress was ignited, only the bedding burned with the king sized bed in the room; however the HRR still reached 400 kW.

One of the concerns in room fires was the risk of a second item igniting due to the radiant heat flux of the first item (in this case, the bedding assembly). By comparing the open hood and room tests it was shown that the room environment enhanced both the HRR and the radiant flux fields (Ohlemiller & Gann (2002)). The risk of ignition of secondary items was estimated using the cone calorimeter data of seven surrogate materials. The most important material was cotton cloth, which could represent the ignitability of curtains or upholstered furniture in close proximity to the bed. The heat produced from the regular and intermediate assemblies indicated the capacity of the ignition of a second item, as they could cause flashover in isolation. Even the heat produced by the low assembly (400 kW) would have been sufficient to ignite a second item in close proximity to the bed.

The CFAST results showed that conditions in room of origin and other rooms in the model house could become untenable in the upper layer of the room within a few minutes of ignition for the intermediate-HRR mattress. Results for the low-HRR mattress also indicated untenable conditions within the upper layer of the room, however the layer remained high, presenting a much lower threat to occupants.

Ohlemiller & Gann (2003) used twin sized mattresses of the same composition as previous investigations (as shown in Figure 2-8) and modified some of the bedding components to monitor the effect on the overall burning behaviour of bedding assembly. Tests were conducted in a NIST 6 m hood calorimeter. The mattress pad, bedspread and pillow were modified by increasing the flame resistance of the fibrefill and adding one of two types of charring barrier inside the shell. The bedding assembly also comprised of two sheets, a blanket and a solid base. Ignition was from a match sized flame impinging on the overhanging sheets and blanket, similar as that used in previous tests (Ohlemiller & Gann (2002); Ohlemiller et al. (2000)).

The modified mattress pads with the protecting sides improved the bedding assembly performance by reducing the HRR and increasing the time to reach the peak. The difference was significant when comparing the results with mattress pads that did not have side barriers. The mattress pads with no sides did not noticeably improve the performance of the bed assembly. Based on these results, it was suggested that a modified bedspread can protect the top and sides of the bedding assembly, however the unmodified components are still partially exposed and the bedspread is not always part of a bedding assembly. Pillows have a big influence on the burning behaviour of the assembly. Pillows can increase the severity of a bedding assembly fire in two ways:

- Contributing a significant portion of the HRR, especially if more than one pillow is present.
- Increasing the HRR can compromise the mattress, increasing the amount of fuel involved in the fire. This occurs because pillows are typically long burning and are generally located where there is little fire resistance over the mattress, due to the absence of charring materials like blankets.

There were often two peaks in the HRR of a bedding assembly, which were more distinct when the mattress had a higher fire retardant. The first was a peak associated with the bedding and was controlled by the bedding characteristics. The second peak was associated with the mattress and base. When the mattress and base became involved in the fire, the bedding had often completely burned away.

Ohlemiller (2003) discussed the validity of using gas burners to simulate the burning of bedding in a bedding assembly for testing purposes. Gas burners are used to improve the repeatability of the tests because the consistency of bedding can not be assured over a long period of time. Tests were conducted in a NIST 6 m hood calorimeter.

Results showed that the peak HRRs reached using the gas burners were an adequate comparison to those recorded when bedding was used. However the time to peak HRR was 15 – 30 minutes slower. The length of the gas burner test was crucial in determining late hazards (occurring after 1 hour). Tests with bedding should still be conducted to identify subtle differences in burning behaviour. As found in previous investigations (Ohlemiller & Gann (2002); Ohlemiller & Gann (2003), for mattresses with improved fire resistance there are two distinct peaks, one associated with the bedding, the other associated with the mattress and base. Table 2-2 presents a summary of the differences in the two methods Ohlemiller (2003).

Table 2-2 Features of Burning Bedding and Gas Burners as Ignition Sources.  
Extracted from Ohlemiller (2003).

Burning Bedding	NIST Dual Gas Burners
Progressive burning (spread flames over bed surface)	Localised burning to one area
Rapid exposure to all vulnerable surfaces	Slow spread to surfaces beyond that exposed
Highly variable heat flux to all bed surface locations	Worst case heat flux to <u>representative</u> locations only
Variable burning and heat flux from identical sets in successive tests	Reproducible heat flux exposure to successive tests
No provision for obtaining identical bedding sets over extended time periods	Uses a simple, reproducible fuel (high grade propane)
Real world exposure condition for mattress/foundation	Simplified exposure condition can miss or underestimate some failure modes

## **2.1.4 Reduced and Small Scale Tests**

### **Reiber (1983)**

Rieber (1983) provided detailed definitions for the components of a bedding assembly and considered different methods of determining the burning characteristics of beds. Reiber (1983) used reduced-scale beds in the tests (mattress 500 mm × 250 mm × 100 mm). The bedding assembly tested consisted of a mattress, sheet, quilted feather or fibre duvet, and feather or fibre pillow.

Cigarettes and matches were reported as the primary cause of accidental ignition of beds. Whereas larger sources like those simulated by crib fires are rare according to accident statistics Reiber (1983). For this reason the following ignition sources were selected for the test series: a bundle of 3 cigarettes, a match and 1 sheet of newsprint rolled into a ball. The cigarettes and the matches were placed on the bed at 5 different locations for each test (directly on the mattress, on the duvet, on the pillow, between the edge of the mattress/duvet and between the edges of the mattress/pillow). The newsprint was placed between the pillow and the duvet.

The results of the tests showed flame retardant cotton sheets over a mattress with cotton ticking and cellulose fibre produced sustained glowing fires. Simply using fire retardant coverings on the bedding (i.e. duvet and mattress cover, and pillow case) was not sufficient to prevent fire growth. A 65/35 polyester/cotton sheet could not sustain a fire when a cigarette was used as the ignition source. Test results showed that the burning characteristics of individual components might not be the same as when tested as part of an assembly. Therefore it was suggested that the bedding assembly can only be classed as fire retardant if all components have compatible burning characteristics and are made from fire retardant materials. Furthermore, it was also recommended that fire retardants should be chosen with care, to ensure combustion products are not excessively toxic and the retardant is durable.

## **2.1.5 Full Scale and Reduced Scale Test Comparisons**

### **Benisek et al. (1985)**

Benisek et al. (1985) suggested that the only fair way to assess the burning behaviour of bed covers is by bed assembly tests. A number of small-scale and full-sized single bedding assemblies were tested in this study. Component tests were also conducted for comparison. The small-scale tests were conducted in a bay (1.25 m × 1.80 m × 2.95 m) within a test room (4.65 m × 6.15 m × 2.95 m). Each test was of at least 60 minutes duration to establish the presence of smouldering combustion, if flaming combustion did not occur. The full-scale tests were conducted in a room-corridor facility; the room (4.6 m × 3 m × 2.5 m) was connected to the corridor (15 m × 1.8 m × 2.4 m) by a doorway.

The small-scale frame was made of metal. The full-scale bed frame was also constructed of metal (2.0 m × 1.0 m × 0.33 m); with the mattress supported by a 150 mm square wire mesh. The mattresses were constructed from a combination of the materials listed below.

- Filling: polyurethane foam or metal springs.
- Wadding: no wadding, fire retardant wool, cotton or mixed fibre.
- Ticking: cotton or fire retardant cotton.

The bedding consisted of two 50/50 polyester/cotton sheets, one feather pillow (with primary and secondary fire retardant cotton covers, to limit their involvement), one or two acrylic, viscose, fire retardant polyester, modacrylic, PVC, wool or fire retardant wool blankets, and a polyester, feather down or wool quilt.

Eight different ignition sources of increasing intensity were used: a cigarette, the three butane flames described in Rieber (1983), and wooden cribs of 8.5 g, 17 g, 60 g and 126 g. The ignition source was either placed in the middle of the bed on top of the covers or at the crease of the folded covers, as shown in Figure 2-10.

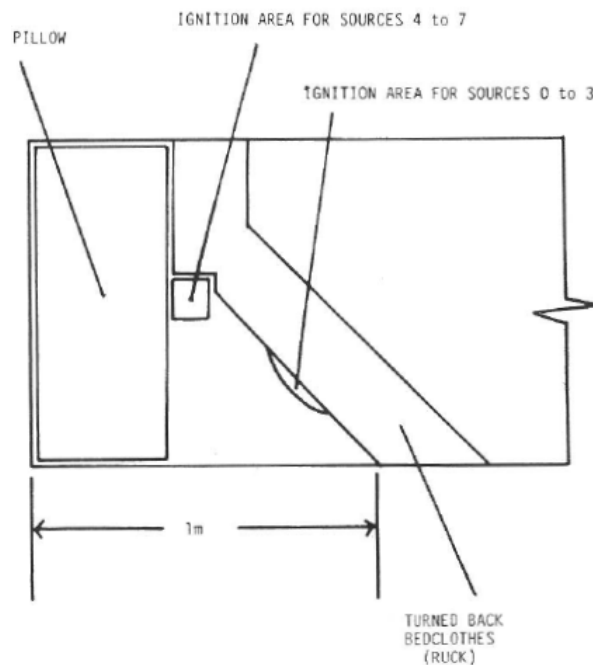

Figure 2-10: Location of the ignition sources. Extracted from Benisek et al. (1985).

The results from the vertical component tests (BS 5866, Part 3:1983) conducted on the blankets, showed no correlation to the results for bedding assemblies. The results from different combinations of bedding assembly showed that for the ignition source on top, the fire spread was dependent on the blanket or the quilt. The wool and fire retardant wool blankets and quilts formed a char, which protected

the rest of the bedding assembly. The other blankets, which melted, exposed the bedding to the fire, causing substantially more damage. The results for the polyester and feather down quilt filling showed the flame spread rapidly over the bed covers. In comparison the wool quilt delayed the flame spread.

When the ignition source was located at the crease, the bedding assemblies, which contained mattresses with fire retardant wool wadding and/or wool blankets, the overall flame resistance improved. These tests confirm results found by Rieber (1983) and Ingham & Edwards (1984), that wool products are effective in increasing the flame resistance of a bedding assembly. The ability of wool to char reduces flame spread and smouldering. When ignition occurred on top of the covers, it was observed that the covers determined the burning behaviour of the assembly. When the ignition source was at the crease, then all components (sheets, mattress wadding, ticking, filling and bedcovers) affect the burning behaviour. Benisek et al. (1985) recommended that more attention needed to be paid to mass loss rate, to assist in the assessment of smouldering combustion and the production of toxic gases.

### 2.1.6 Room Burn Tests and Free Burn Test Comparisons

#### Lee (1985)

Lee (1985) performed a number of tests to determine the burning behaviour of bedroom fires in U.S. park services' lodging facilities. A number of free burn tests were conducted, as well as room tests that were performed in the set up shown in Figure 2-11. A number of the free burn test and room test results are available on FASTData NIST (1999), including the HRR curves and upper and lower layer temperatures for the room tests. The bedrooms consisted of a double bed, bedding assembly (with a head board), a night table, and a waste paper basket that was used as the ignition source.

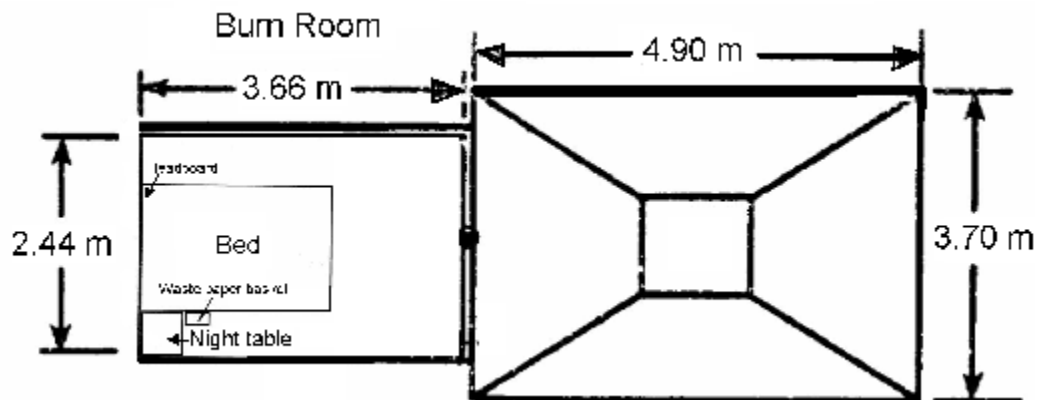

Figure 2-11: Schematic of the set up for the room tests conducted by Lee (1985).

The spring mattress and the box spring base had a wooden frame with a steel wire grid and a polyester quilted cover. The padding was polyurethane over fire retardant cotton felt with sub-layers of cotton felt and synthetic cellulosic fibre pad. The bedding consisted of 2 polyester/cotton sheets, 2 pillows (with polyester fill, polypropylene olefin covers and polyester/cotton pillow cases), and an acrylic blanket.

A single wall located behind the headboard with a combustible (plywood) or noncombustible wall lining (gypsum) was also installed in both the free burn and the room burn experiments. The ignition source was a 0.34 kg polyethylene wastepaper basket with 0.41 kg of trash, consisting of different paper items. The trash was ignited with a match. The wastepaper basket was located adjacent to the night table and against the bed.

All the free burn experiments showed similar burning characteristics, with an initial peak, which corresponded to the bedding being consumed and exposing the mattress. A period of slower burning and/or smouldering then occurred until there was sufficient heat to support flaming combustion of the mattress and base, which corresponded to a second peak. The tests containing the plywood wall had an extended period of burning associated with the second peak. This was attributed to the full contribution of the plywood wall to the fuel load. The presence of the non-combustible wall had negligible effect on the burning behaviour of the assembly.

The characteristics of the fire in the early stages of the room tests were similar to the free burn tests; however the later stages of the fire were more severe. The hot combustion gases trapped under the ceiling radiated back onto the burning furnishings. This was observed in the heat flux measurements taken from the end of the bed. The heat flux increased from 20 kW/m<sup>2</sup> in the free burn tests to 130 kW/m<sup>2</sup> – 220 kW/m<sup>2</sup> in the room tests. The room test with the combustible plywood linings resulted in flashover at 290 s after ignition. This was attributed to the significant increase in combustible material and enhancement in burning rate due to radiation feedback. A comparison of heat release rates (HRR) associated with the free burn and room burn, with the plywood wall lining, is shown in Figure 2-12.

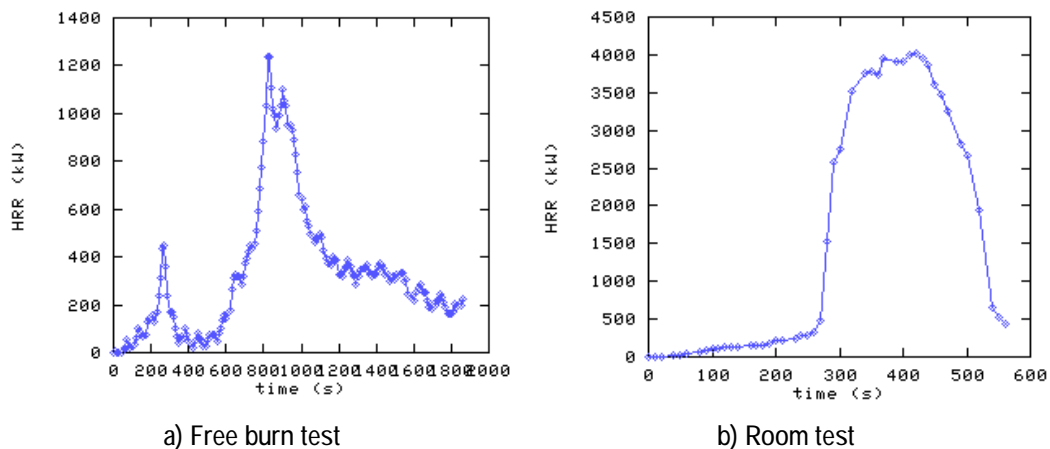

Figure 2-12: Heat release rate profiles of a bedroom with plywood wall linings. Note the change in scale.  
Extract taken from Lee (1985).

The peak carbon dioxide (CO<sub>2</sub>) concentration also increased in the room tests (1.5 g/s – 2.1 g/s) compared to the free burn tests (4.6 g/s – 23.5 g/s). This is a significant increase when considering life safety, however there was negligible difference in the total CO<sub>2</sub> produced 1.3 kg<sub>9</sub> – 1.71 kg and 1.48 kg – 2.38 kg, for the free burn and room tests, respectively. The difference in the results from the free burn tests and the room burns with the non-combustible gypsum wall linings was also insignificant when comparing peak smoke concentration and total smoke production measurements (1.3 O.D./m – 1.5 O.D./m and 1850 m<sup>2</sup> – 2430 m<sup>2</sup>). However in the plywood room burns the peak smoke concentration and the total smoke production was double that of the other tests (2.1 O.D./m – 3.0 O.D./m and 4190 m<sup>2</sup>).

### 2.1.7 Bedding

Pillows can have a significant effect on the burning behaviour of a bedding assembly. If they do not ignite, then the HRR and fire intensity of the bedding assembly is reduced. However if the pillow ignites, it may produce sufficient heat to ignite other bedding components, which would not otherwise ignite. Therefore the burning characteristics are important when considering the whole bedding assembly.

#### Babrauskas (1985)

Babrauskas, V. (1985) quantified the HRR of pillows made of five different materials, as shown in Figure 2-13. Six balls of newspaper placed inside the pillowcase opening was used as the test ignition source.

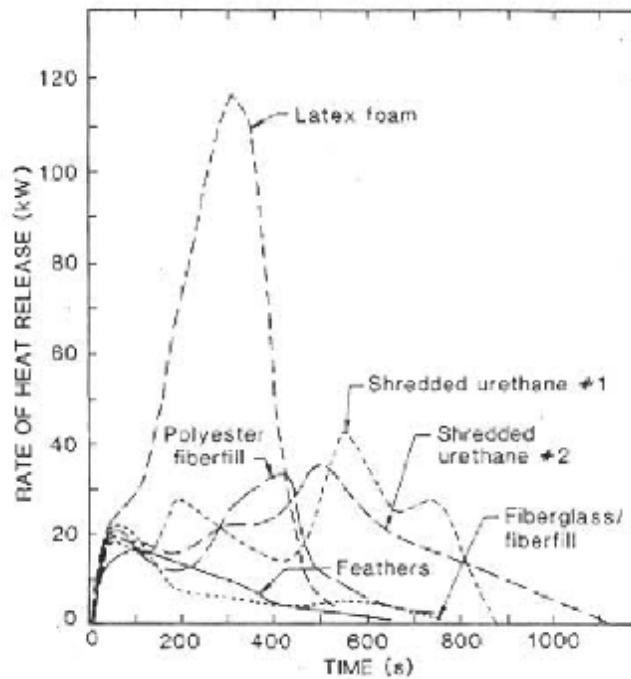

Figure 2-13: HRR curves for various pillows. Extracted from Babrauskas (1985).



Each pillow, as shown in Figure 2-13, had an initial peak HRR of 20 kW. This was attributed to the ignition source. The ranking from best to worst in terms of performance (where the best is considered the lowest HRR and total heat released) was: fibre-fill with fibreglass cover, feathers, fibre-fill, polyurethane foam and latex foam. The latex pillow performed the worst, burning the most rapidly, with peak HRR of 117 kW and total heat release of 27.5 MJ. The peak HRR for other pillows ranged from 43 kW – 16 kW, with a total heat release of 18.9 MJ – 3.1 MJ.

## **2.2 Literature Summary of Beds and Bedding Fires**

Following is a summary of the results and observations presented in the reviewed literature for investigations of beds and bedding flammability data:

- A tightly made bed has slower flame spread than a loosely made bed or an unmade bed, Krasny et al. (2001).
- Results from tests using small-scale models (i.e. models smaller than half scale) deviated significantly from full-scale results, Paul (1980). This is an indication that an incorrect combination of parameters has been used to scale the models.
- Cigarette and matches are the primary cause of accidental ignition of beds. Larger sources, like those simulated by crib fires, are rare according to accident statistics, Rieber (1983).
- A fire retardant covering on bedding components was demonstrated to be insufficient to prevent fire growth, Rieber (1983).
- Bedding assemblies can only be classed as fire retardant if all components have compatible burning characteristics and are made from fire retardant materials, Rieber (1983).
- Vertical component tests on blankets showed no correlation between the component tests and results from testing the entire bedding assembly, Benisek et al. (1985).
- Wool products were shown to be effective in increasing the fire resistance of a bed assembly. This was attributed to the ability of wool to char, which reduced flame spread and smouldering, Rieber (1983).
- Solid foam mattresses showed significantly more flame propagation and burnout than inner spring mattresses which smouldered and self extinguished, Sundström (1994).
- The burning behaviour of polyurethane mattresses was shown to be highly sensitive to the surrounding environment, Babrauskas, V. (2002).
- The flame spread across blankets varied, depending on the material. The flame spread across some representative blankets on a bedding assembly was ranked from very fast to very slow: acrylic blanket, polyester filled duvet, cotton blanket, wool filled duvet, wool blanket, Ingham & Edwards (1984)

- The burning behaviour of bedding assemblies in the early stages of a room fire was reported as similar to a free burn fire, Lee (1985).
- Pillows may significantly affect the burning behaviour of a bedding assembly, Babrauskas, V. (1985).
- At the point when the fire spread from the bedding to the pillows the HRR and smoke production increased considerably. This was attributed to the availability of a greater combustible mass and the additional heat released increases the risk of other items igniting, Paul (1989).
- Conditions were observed to change significantly with increasing fire load. The relationship between resulting conditions and fire load was greater than linear, Luo & Beck (1996).
- Untenable conditions have been observed to extend past the room of origin, Luo & Beck (1996).
- Room fire scenarios have been successfully modelled using a CFD approach, Luo & Beck (1996).
- Mattresses containing foams, which comply with TB 117, do not necessarily comply with full-scale tests. For example, TB 129, Damant & Nurbakhsh (1992); Nurbakhsh & McCormack (1998).
- Fire retardant treatments can delay or slow fire growth, but have equal severity; reduce the maximum HRR, but still consume most of the (combustible) mass; or they can limit the mattress involvement (self-extinguishing), Ohlemiller et al. (2000).
- Unique failure modes of mattresses can occur when bedding is used. For example, over pressurisation of the mattress has been observed, where a flammable gas mixture was created within the mattress causing the seam to rupture and allowing fire penetration into the interior of the mattress. These effects could not be simulated when testing mattresses with gas burners simulating the bedding, Ohlemiller et al. (2000).
- Consistent with tests results there are often 2 peaks in the HRR for bedding assemblies. The first is due to the bedding and the second is due to the mattress and base, Ohlemiller & Gann (2003).

### 3 Literature Review – Characteristics of Upholstered Furniture Fires

Combustion properties of upholstered seating can be extrapolated from data of small-scale tests in the cone calorimeter, and larger scale tests. For example, chair mock-ups and full-scale chair burns. Chair mock-ups are made up of cushions, as shown Figure 3-1, where arm chairs are represented four cushions with a back, a seat and two arm cushions. Similarly, loveseats (2-seater sofas) and 3-seater sofas can be represented by 6 and 8 cushions, respectively. There are a number of different styles of arm chairs and 2-seater sofas and 3-seater sofas. Details, including the chair size, type, design and construction materials can have a significant effect on the ignition propensity and resulting fire.

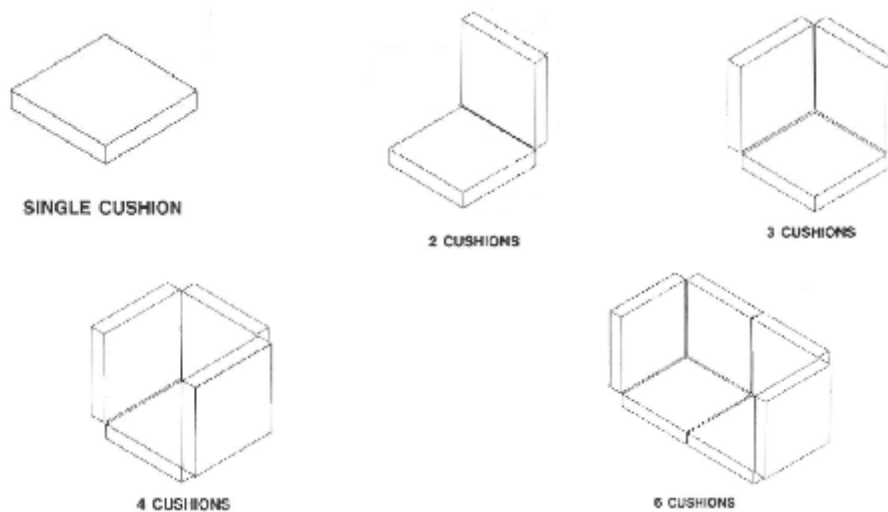

Figure 3-1: Configurations of chair mock-ups. Extracted from Krasny & Babrauskas (1984).

#### 3.1 Literature Annotation

##### 3.1.1 NBS Furniture Calorimeter

###### Lawson et al. (1984)

The results of a number of furniture items tested in the NBS furniture calorimeter in 1983 were reported by Lawson, J. R. W. et al. (1984). The HRR, mass loss rate, thermal irradiance, carbon monoxide and smoke concentration were measured and recorded. The upholstered items investigated were five easy chairs, one sofa and two loveseats, as described in Table 3-1.

Table 3-1: Upholstered furniture items tested by Lawson, J. R. W. et al. (1984)

Upholstered Item	Frame	Foam	Fabric
Easy Chair (45)	Wood	Cal 117	Polyolefin
Easy Chair (48)	Polystyrene-plywood	polyurethane	Polyurethane with polyolefin backing
Easy Chair (49)	Wood	polyurethane	Cotton
Easy Chair (64)	Cold moulded polyurethane foam/ wood/ springs	polyurethane	Imitation leather/ polyester batting
Easy Chair (66)	Wood	polyurethane-polyester fibrefill	Cotton & paper welted cord
3-seater Sofa (38)	Wood	Cal 117	Polyolefin
Loveseat (54)	Metal	polyurethane	Plastic coated fabric
Loveseat (57)	Oak wood	polyurethane	Plastic coated cotton

A number of office/waiting room type chairs were also tested. The office chairs/waiting room type chairs were made of different combinations of the following materials:

- Fabrics: polyolefin, cotton, synthetic fibre, polyester fibre, plastic coated fabric
- Padding/Foam: Cal 117, polyurethane foam, latex foam rubber, vegetable fibre
- Frame: wood, polypropylene, polyurethane

Unless otherwise specified, the ignition source was a 50 kW gas burner, which was located 25 mm from the side of the chair.

The easy chairs were all different styles and, unfortunately, the details of the designs were not specified with the results. The easy chairs have been characterised by construction materials: frame/padding/cover material and referenced to Table 3-1. The relevant results of the burning characteristics have been summarised below:

- The peak HRR value for both Easy Chair (45) and Easy Chair (48) (2100 kW and 960 kW, respectively) indicated that room flashover would be likely. The HRR increased rapidly, reaching the peak around 300 s after ignition.
- Easy Chair (48) also had the greatest smoke production and thermal irradiance.
- Easy Chair (49) had the most favourable burning characteristics with a peak HRR of 210 kW.

- The ignition source for Easy Chair (66) was a smouldering cigarette located in the seat-arm crevice. The easy chair smouldered for 3700 s before flaming combustion occurred. The HRR then increased rapidly to reach a peak of 640 kW within 200 s.
- Loveseat (54) with the metal frame had a lower peak HRR than the Loveseat (57) and Sofa (38), 370 kW at 450 s.
- The Loveseat (57) was the most difficult to ignite due to plywood panels at the ends of the loveseat where the ignition source was located. Flaming combustion was established once the seat and back cushions were involved causing rapid fire growth and a peak HRR of 1100 kW at 800 s.
- Sofa (38) had a peak HRR of 3000 kW in 250 s which was the highest of all the furniture items tested in this paper; it also produced the highest total heat released, thermal irradiance and CO concentrations.

In general, two types of burning behaviour were observed for the easy chairs: a short sharp peak HRR or a lower peak HRR with a period of steady burning after the peak HRR was achieved. Examples of these two types of HRR measurement are shown below in Figure 3-2. Figure 3-2 a) shows the results for a 'wood/Cal 117/polyolefin' Easy Chair (45), with a short sharp peak in the HRR measurement. Figure 3-2 b) shows the results for a 'wood/polyurethane/cotton' Easy Chair (49), with a lower peak HRR measurement followed by a period of steady burning.

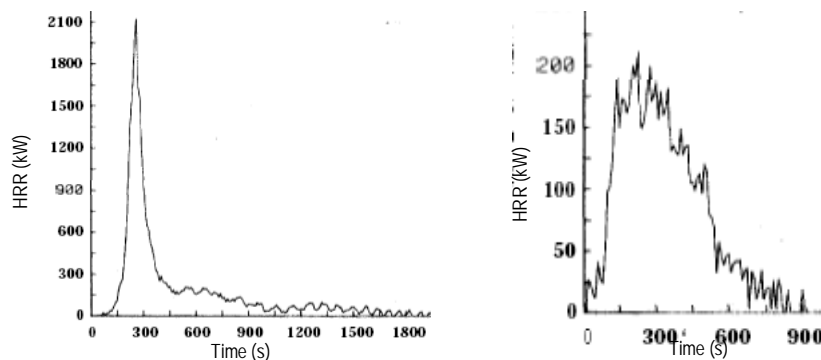

a) 'Wood/Cal 117/polyolefin' Easy Chair (45)      b) 'Wood/polyurethane/cotton' Easy Chair (49)

Figure 3-2: Examples of HRR profiles for easy chairs. Note the difference in scale between a) and b).  
 Extracted from Lawson, J. R. W. et al. (1984).

In particular, the results for the loveseat with the wooden frame showed that a delay before the onset of rapid fire growth would probably have been shorter or absent by moving the ignition source to the seat or back cushion. With this in mind, the location of the ignition source could be significant when considering life safety in fire engineering design. Similar to the results for the easy chairs, the HRR

measurements showed one distinct peak HRR for each of the above tests, with either a high sharp peak or a lower peak followed by steady burning (see Figure 3-3). Figure 3-3 a) shows the results for a 'wood/Cal 117/polyolefin' Sofa (38), with a short sharp peak in the HRR measurement. Figure 3-3 b) shows the results for a 'metal/polyurethane/plastic coated fabric' Loveseat (54), with a lower peak HRR measurement followed by a period of steady burning.

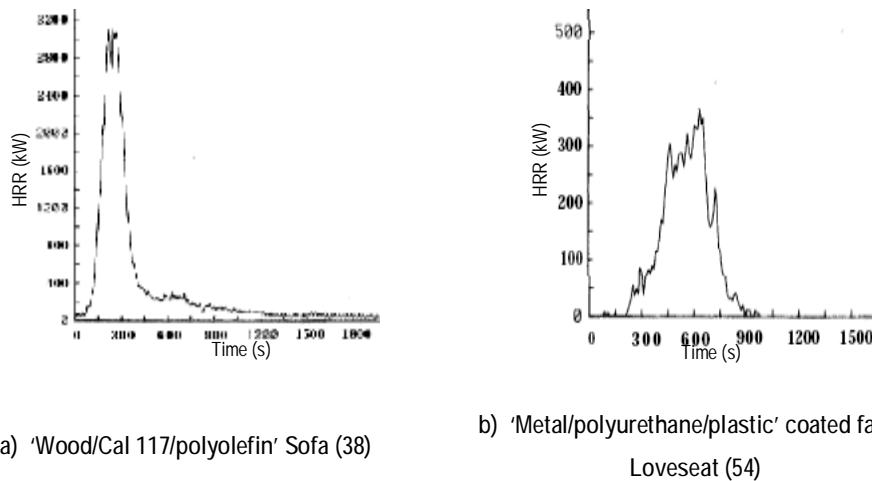
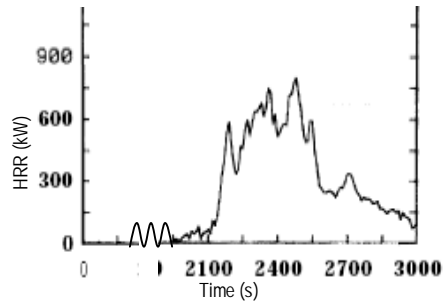
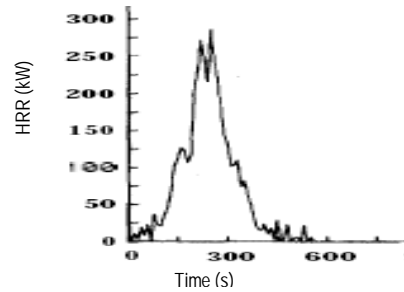

Figure 3-3: Example of HRR profiles for a sofa and loveseat. Note the difference in scale between a) and b). Extracted from Lawson, J. R. W. et al. (1984).

The office/waiting room type chairs that were investigated were commonly used in commercial buildings, but could often be found in residential buildings. The amount of combustible materials on these chairs was often significantly less than the easy chairs, which were discussed earlier. The smaller amount of combustible materials was attributed to very low peak HRR measurements. For example, a metal frame chair with an upholstered seat cushion peaked at 3 kW. The office/waiting room type chairs were constructed from similar materials to the easy chairs or from moulded plastics frames, with varying amounts of upholstery. Examples of the burning behaviour of office chairs are shown in Figure 3-4. Figure 3-4 a) shows an example of the HRR measurements for a moulded plastic office chair. Figure 3-4 b) shows an example of the HRR measurements for an office chair, with a metal frame and foam cushions.



a) Moulded plastic office chair



b) Office chair, with a metal frame and foam cushions

Figure 3-4: Example HRR profiles for office chairs. Note the difference in scale between a) and b).  
Extracted from Lawson, J. R. W. et al. (1984).

### Babrauskas

In the SFPE Handbook, Babrauskas, V. (2002), referred to NBSIR 82-2064, Babrauskas, V. et al. (1982), Babrauskas, V. (1983) and a 'Flammability Information Package' published by the Bureau of Home Furnishings, California (1987). The package included TB 116, 117, 121, 133, 106 and 21, and illustrated the general burning behaviour recorded for full-scale tests Bureau of Home Furnishings, California (1987). The information available for upholstered furniture in this chapter also summarised some of the findings published in the CBUF report (Sundström (1994). Specifically CBUF Model I, which predicts burning behaviour from small-scale cone tests, however this model is not within the scope of this literature review.

The development of the furniture calorimeter has been described by Babrauskas, V. (1983). Before the development of the furniture calorimeter, room tests were used to assess the burning characteristics of items. Babrauskas (1983) identified the differences between room tests and furniture calorimeter tests. The peak HRR and the time to peak HRR were considered the most important variables, when considering the burning characteristics.

The burning characteristics of thirteen upholstered seats were identified. The HRR profile of the item was determined using oxygen consumption calorimetry. Ten armchairs were constructed in a combination of the materials listed below.

- Frame: wood, polypropylene or polyurethane
- Padding/Foam: Cal 117, fire retardant cotton batting, Non Cal foam or foam/cotton/polyester
- Fabrics: polyolefin or cotton

Cotton was the representative material for cellulosic fabrics, while polyolefin was the representative material for thermoplastic fabrics. Two loveseats and a three-seater sofa were also tested. The ignition

source was a gas burner simulating a wastepaper basket fire. The burner was located adjacent to the left arm of the chair. Examples of the chairs used in the tests are shown in Figure 3-5.

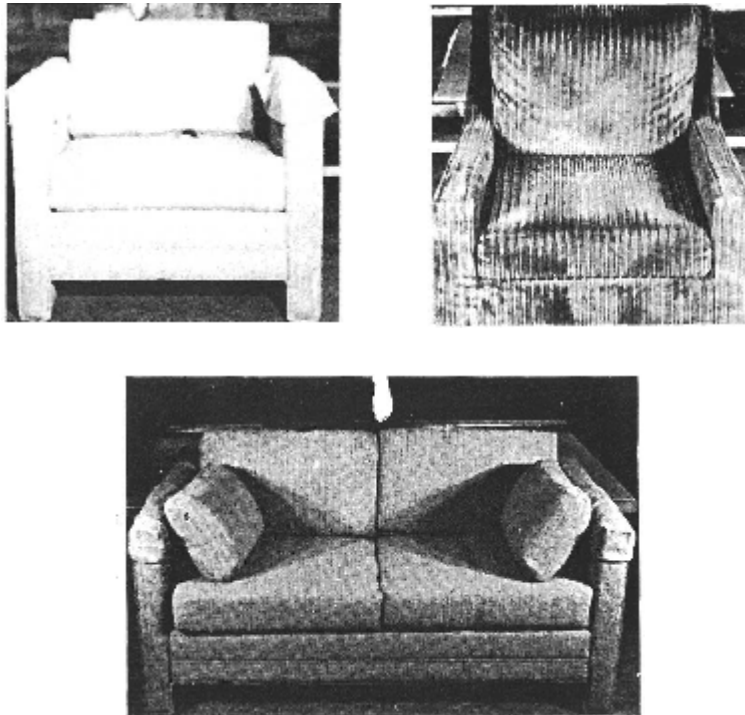

Figure 3-5: Examples of chair designs used in testing. Extracted from Babrauskas, V. (1983).

In general, it was observed that the flames spread along the left arm to the outside back of the chair, then to the seat and inside back of the couch. Flame spread to the right arm of the chair was dependant on the fabric. For the polyolefin (thermoplastic fabric), the ignition was due to radiation caused by the rapid involvement of the foam. For the cotton (cellulosic fabric) covers, the ignition was due to flame spread across the couch. In all cases, the front of the chair was the last to ignite and in most cases pool burning occurred under the chair, created by the melted padding. Tests were terminated once flaming ceased, therefore the smouldering potential was not considered in these tests.

Barbrauskas (1983) concluded that the main advantage of furniture calorimeter tests over room tests was the ability of the furniture calorimeter tests to calculate the HRR using oxygen consumption calorimetry. Some of the HRR results are summarised below.

The results showed that seats constructed out of cotton fabric and cotton batting had the slowest developing fire (920 s to peak HRR) and the lowest peak HRR (370 kW). The cotton fabric with polyurethane foam, polyolefin fabric with cotton batting padding, and the seats containing mixed cotton batting and foam padding, all had fires that developed at an intermediate rate (420 s – 650 s). The peak HRR values ranged from 700 kW to 1060 kW, which was also considered in the intermediate range of



HRR values. The loveseat, constructed with mixed padding and cotton fabric, showed a comparable growth rate of 560 s, with a peak HRR of 940 kW, which was within the range of the armchairs.

The seats containing foam padding and polyolefin fabric had rapid fire growth (220 s - 280 s) and high peak HRR values ranging from 1950 kW to 1990 kW. The results from these tests also indicated that the framing material did not significantly affect the burning behaviour of the chairs. The loveseat and the sofa, constructed from polyurethane foam and polyolefin fabric, reached the HRR peaks at similar times to the single armchairs of the same construction (230 s and 250 s, respectively). Increased fuel load were attributed to the higher peak HRR values (2890 kW and 3120 kW, respectively).

The tests analysed by Krasny & Babrauskas (1984) formed part of a development of test methods to quantify the burning characteristics of furnishings and furniture. The tests were conducted in a furniture calorimeter and the temperature, CO, CO<sub>2</sub> and O<sub>2</sub> concentrations, total gas flow, smoke development, mass loss, radiation 0.5 m in front and 0.2 m above the front edge of the seat cushion and HRR were measured.

Five different configurations of full-scale mock-ups were analysed, as shown in Figure 3-1. The results for the 4 cushion and 6 cushion mock-ups represent an armchair and a love seat respectively. These results have been included in the summary table.

The cushions were 610 mm × 610 mm with a fabric cover over all foam surfaces. Different fabric/foam combinations were tested and no interliners were included in these tests. The fabrics tested were heavy weight olefin with backcoating, light weight olefin with backcoating, heavy weight cotton with backcoating and light weight cotton. The foams tested were standard polyurethane foam, fire retardant polyurethane foam and neoprene foam. Two thicknesses of each type of foam were tested. For the polyurethane foams, thicknesses of 100 mm and 50 mm were tested. For the neoprene, thicknesses of 80 mm and 40 mm were tested.

Two ignition sources were used; the first ignition method was a 150 mg methenamine pill, which was placed either in the centre of the seat offset from the back by 100 mm or in the crevice of a seat/back/arm junction. The second ignition source was 25 mm × 50 mm strips of alpha-cellulose chromatography paper (4.5 g or 9.0 g). These strips were stacked and folded to sit against the seat and the back cushions. The strips of paper were ignited by a match.

The olefin fabric over the standard polyurethane foam burned rapidly. As the olefin fabric melted away it exposed the foam. This combination resulted in the highest peak HRR in the shortest time after ignition. Cotton covers over the standard polyurethane foam had slower burning rates, because the cotton charred. However once the charring split and exposed the foam, the fire grew rapidly to peak HRR values comparable to the combinations with the olefin covers. The fire retardant foam did not

ignite or burn as readily as the standard foam. As a result of this, the mock-ups containing fire retardant foam burned more slowly than the standard foam mock-ups, but reached similar peak HRR values. The neoprene foam mock-ups did not support flaming combustion; instead the foam around the ignition source smouldered. However for the neoprene foam covered by olefin fabric, the olefin melted and formed a small pool fire.

The mock-ups performed differently, depending on the type of foam. The neoprene foam did not sustain flaming combustion. The standard polyurethane foam ignited and burned readily. The fire retardant polyurethane foam burned more slowly than the non-treated foam, but eventually reached similar peak HRR values. The fabric affected the fire growth and flame spread until the foam was exposed. The burning characteristics were then dominated by the characteristics of the foam. The thinner cushions burned more rapidly than the thicker cushions.

### **3.1.2 CBUF**

#### **Sundström (1994)**

The CBUF study (Sundström (1994) tested a number of full-scale chairs and sofas, which were commercially available, and a number of full-scale models, which were constructed specifically for the furniture tests. Single item tests were conducted in the furniture calorimeter, ISO 9705 room and a larger test room (5.7 m × 7.37 m × 4.0 m). The commercially available items varied from fully-upholstered armchairs, loveseats and sofas to basic office chairs and executive swivel chairs. The full-scale models of upholstered chairs, loveseats and sofas tested changed for different variables. For example; fabrics, interliners, foams, gaps between cushions, framing material and design.

The test results showed the presence of armrests could increase the radiation feedback onto the seat. If ignition was within the seat area, a higher HRR was achieved and the fire growth was also faster with the peak HRR reached 60 s – 120 s faster than similar chairs with no armrests. A higher backed chair produced a slightly higher HRR, which was attributed to the extra combustible mass present. If there were gaps between the seat cushion and other cushions, the fire growth was slower but the peak HRR was similar. Chairs, where the cushions were supported by webbing, showed faster fire development and higher HRR values. The fire was observed to burn through the interior structure, producing a pool fire to form on the floor below the chair. Chairs of a similar design with solid wood panelling had slower fire growth and significantly lower peak HRR values (361 kW compared to 821 kW). Button tufting was another variable tested using the full-scale models. However no detectable difference in burning behaviour was caused by button tufting.

The framing used in chairs was usually no frame or it was made of wood, metal, thermoplastic or thermosetting materials. Chairs with no frames were not tested in the CBUF study, since earlier studies

had found chairs with no frames were very hazardous due to large amounts of easily combustible material. For example, bean-bags and foam-block chairs. Sundström (1994) noted that wooden framed chairs were the most common in the commercial market.

During the tests, it was observed that the frame was not usually involved until the later stages of the fire. Therefore the peak HRR was not affected by the combustion of the framing material. However the construction of the frame did affect the burning behaviour. For example, if corrugated metal plates or similar connectors were used, the frame sometimes collapsed in the early stages of the fire. Early failure sometimes exposed large quantities of concealed material to the fire, resulting in rapid fire growth and a higher peak HRR. The chairs with metal frames had similar burning characteristics to the wooden frame chairs, however the joints in the metal frames did not fail from the thermal effects of the fire. The thermoplastic frames performed worse than the wooden frames, but better than the thermosetting frames. The office chairs tested often had metal frames with hard plastic shells. In these cases, the performance depended on the burning behaviour of the plastic. Plastic that melted tended to form a pool fire under the chair, accelerating the burning rate and increasing the peak HRR.

The results of the study indicated that the peak HRR correlation between armchairs, loveseats and sofas was greater than linear, with the high HRR resulting from an increased amount of combustibles. However in a room environment the armchair was the worst case scenario in the early stages of a fire. This was attributed to the acceleration in the growth rate due to radiation feedback.

### **Enright et al. (2001)**

Enright et al. (2001) conducted a study on exemplary New Zealand (NZ) upholstered furniture following the CBUF protocol. The purpose was to examine the goodness of fit of NZ furniture with CBUF model II. A number of cone calorimeter tests were completed to input into the CBUF model, however these results will not be discussed in this review. Thirteen full-scale items were then tested in the furniture calorimeter to validate the CBUF model II results.

There were three styles of armchair and one style of two-seater sofa tested, as shown in Figure 3-6. The materials used in the upholstered items were:

- Fabrics: Polyester & blends, nylon with polyester backing, polypropylene, nylon with 65% polyester- 35% cotton backing, nylon.
- Interliner: General fibre.
- Foam: Polyether foam, standard polyurethane foam.



Figure 3-6: Upholstered furniture designs tested. Extracted from Enright et al. (2001).

The HRR was recorded for each of the full-scale tests and these were compared with the predictions made by the CBUF model II. The analysis found the model did not predict the burning behaviour of the exemplary NZ furniture very well. The results for the furniture were then compared with results from comparable items in the CBUF study. The CBUF items had a similar style/design, fabric, interliner and foam. It was found the NZ furniture consistently produced a significantly higher peak HRR, though the total heat released was similar.

#### **Fleischmann and Hill (2004)**

Fleischmann & Hill (2004) described the burning behaviour of upholstered furniture based on tests on 55 single upholstered chairs and upholstered two-seater sofas. The designs of the chairs were the same as the CBUF Series II. The tests were conducted in a furniture calorimeter, according to the CBUF protocol. The chairs were made of combinations of the fabric, interliners and foams shown below:

- Fabrics: Wool, cotton, polyester, or polypropylene.
- Interliner: -
- Foam: Domestic (standard polyurethane foam), commercial (HR polyurethane foam), or aviation (CMHR foam).

The materials used were those typically available commercially in New Zealand, where there are currently no fire regulations on upholstered furniture. The ignition source was a 30 kW burner, as specified in TB 113 (Ohlemiller & Villa (1992).

The tests identified four distinct phases during burning, excluding the ignition phase. These were (1) Spread, (2) Burn Through, (3) Pool Fire and (4) Burnout.

- The spread phase was identified by the flame spread from point of ignition over the seat and back of the chair, then on to the armrests.
- The burn through phase occurred once flames had spread over the surface of chair and steady state burning occurred. This phase ended once the fire had burned through the seat of the chair.
- The pool phase occurred if the fire burned through the chair, causing molten foam and fabric to form a pool of fuel below the chair. The HRR then increased rapidly to the peak HRR, due to the increase in oxygen available to the fuel pooled on the floor.
- Once the peak HRR had been reached the chair entered the burnout phase, which continued until all the fuel was exhausted or the fire was extinguished.

When the chairs were constructed out of readily combustible materials with low ignition resistance, the burn through phase was non-existent. The fire grew so rapidly that the pool phase followed the spread phase, bypassing burn through. If the chair had high fire resistance, the pool phase did not occur due to insufficient heat production preventing burn through of the chair. The burn through phase was also shortened when the chair self-extinguished.

### **3.1.3 Various Furniture Fire Tests**

#### **Särdqvist (1993)**

Särdqvist (1993) collated the results from a number of experiments for items ranging from building materials, warehouse stock to furniture and furnishings. The database included furniture calorimeter tests, different sized room tests and room tests with varying degrees of ventilation. The range of information from the tests included a detailed description of the item, HRR profile, mass loss profile, CO concentrations, smoke concentrations, etc. There were tests with mock-ups, armchairs, easy chairs, loveseats and sofas. The results showed a wide range of burning behaviour from poor to excellent.

#### **Andersson and Magnusson**

Andersson, B. & Magnusson (1985) described a study of 53 reduced-scale experiments and 11 full-scale experiments carried out in 1978 and 1979. The HRR and smoke production results were presented. The experiments were conducted in a test room, which was instrumented to measure temperature, smoke production, heat flux and mass loss rates. This review focused on the results from the full-scale tests. Different combinations of the fabric, interliners and foams were used to construct full-scale three-seater sofas on a steel frame. The materials that were used are listed below.

- Fabrics: wool, acrylic and 61% / 39%, wool / acrylic
- Interliner: fire retardant polyurethane, modified neoprene foam and novoloid fibres
- Foam: standard polyurethane foam, fire retardant polyurethane foam and HR polyurethane foam.

The ignition source used was a 20 kW – 30 kW liquid fuel burner. It appears the burner was located near the seat-back crevice.

The HRR was calculated using two methods: a) using the temperature and gas flow out of the room, and b) using the mass loss rate and an averaged heat of combustion. The peak HRR for an acrylic-/standard polyurethane was reported as 1400 kW, at 240 s. When the sofa was constructed out of wool-viscose/-fire retardant polyurethane foam the peak HRR reduced to 580 kW and the time to peak HRR increased to 1320 s (22 minutes). The HRR values were calculated using the mass loss rate and a heat of combustion of 18.7 MJ.kg<sup>-1</sup>.

The conclusions drawn from these tests included:

- The fabric used for the covers can significantly influence the burning behaviour of the sofa.
- The fabric can affect the ignitability, rate of fire spread and the HRR profile.
- From observations, the interliners considerably decrease the rate of fire spread and fire growth of the sofas.
- Smoke density measurements indicate that the total amount of smoke produced depends on the combination of materials used.

### **Schumann and Hartzell (1989)**

Schumann & Hartzell (1989) characterised the flaming combustion of upholstered furniture by burning specially made armchairs in a room calorimeter. The room calorimeter was 2.74 m × 2.74 m × 2.74 m. The inlet air was supplied by an external blower and distributed through hoses on the room floor. The air was exhausted through a stack in the centre of the ceiling. The armchair was placed on a load cell and the room and stack was equipped with thermocouples, photometer, flow meters, and a gas analyser measuring CO<sub>2</sub>, CO, O<sub>2</sub> and CH<sub>x</sub>. A schematic of the layout for the testing is shown in Figure 3-7

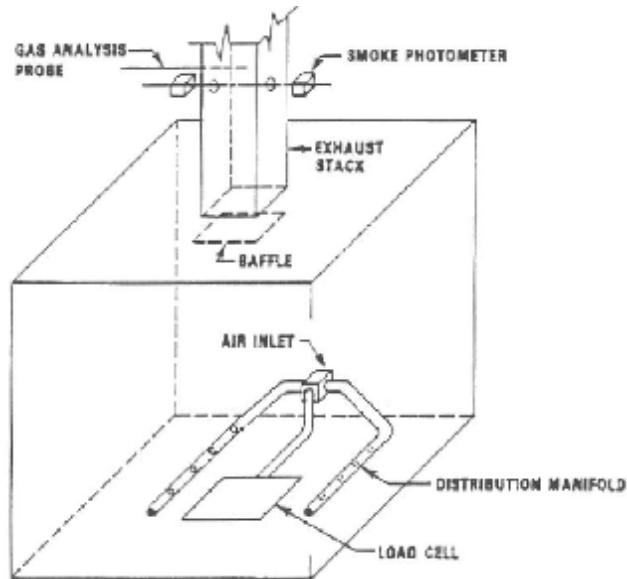

Figure 3-7: A schematic of the layout used for testing armchairs in a room calorimeter. Extracted from Schuhmann & Hartzell (1989).

The chairs were constructed with a wooden frame with foam cushions and a cover fabric. Some chairs contained interliners. The design was the same for each test specimen with 10 different cover/interliner/foam combinations tested. The materials used were:

- Fabrics: Polypropylene, cotton, or vinyl on cotton.
- Interliner: Fibreglass.
- Foam: Standard polyurethane foam, high-resilience (HR) polyurethane foam, melamine-treated polyurethane foam, or combustion modified polyurethane foam.

The ignition source was a premixed natural gas flame with a calculated output of 70 W. The ignition source was located at the centre of the chair, against the back cushion, 16 mm above the seat. The effects of background heat flux of 0.125, 0.22 or 0.9 W/cm<sup>2</sup> on approximately 75% of the seat and back cushions was also tested for six of the combinations.

It was observed that the ignition resistance and the rate at which the fire spread was dependant on the fabric cover. Polypropylene ignited rapidly, while the cotton initially smouldered before spontaneously changing to flaming combustion. The vinyl on cotton required an additional heat flux before it would ignite. A number of the chairs showed two distinct peaks in their HRR profiles. The first peak was smaller attributed to the cover fabric. The second, larger, peak was attributed to the foam as the main contributor to the fuel. The modified foams (melamine treated and combustion modified) only ignited when the heat flux was added. The fire performance was also improved by decreasing peak HRR values by 20% – 40% with the use of the melamine treated and combustion modified foams,

respectively. Significant increases in the time to peak HRR were also measured. When interliners were present, the involvement of the foam in the fire was either prevented or delayed.

In the analysis of the results, time  $t = 0$  s was considered to be the time at which flaming combustion started. In the cases where 2 peaks were observed, the second higher peak was recorded, unless the first peak was greater than 90% of the second peak. The peak HRR was predominantly dependent on the foam, with the peak HRR for the standard and HR foams around 600 kW. Lower HRR values occurred when the chairs had interliners or vinyl on cotton fabric covers (220 kW – 350 kW). The modified foams had peak HRR values ranging from 100 kW – 530 kW, depending on the heat flux applied to the chair. The time to peak HRR varied from 210 s to 450 s. When interliners or modified foams were used, the time to peak HRR increased from 20 minutes to over 2 hours.

### **Fesman and Jacobs (1989)**

Fesman & Jacobs (1989) looked at upholstered furniture intended for public occupancies. The study used three different test methods to evaluate the same combinations of materials:

- California Technical Bulletin, which is a room test (3.7 m × 3.0 m × 2.4 m) with a doorway (0.87 m × 2.0 m) for ventilation. Mock-ups or full-scale chairs can be used. Five double sheets of loosely wadded newspaper are used as the ignition source. Temperature, smoke opacity, CO concentration and mass loss rate are monitored.
- City of Boston Fire Department Procedure BFD IX-10, is also a room test (3.7 m × 2.4 m × 2.4 m). A two-cushion mock-up or a full-scale chair can be used in this test. The ignition source was a brown paper bag filled with four double sheets of loosely wadded newspaper. The flaming behaviour, excessive smoke production, time fire self-extinguishes and mass loss rate are monitored.
- British Standard BS-5852 Part II, requires a room greater than 20 m<sup>3</sup> with inlet and exhaust airflows. A two-foam-fabric-cushion mock-up is tested on a steel and wire mesh frame. The ignition source is a size 7 wood crib. Various flaming behaviour properties are monitored during the test.

No interliners were used and the foam used in all test specimens was melamine HR polyurethane foam. For each test, 5 cover fabrics were used:

- 55%/ 45%, wool / nylon with acrylic backing,
- 75%/ 25%, modacrylic/ nylon with fire retardant backing,
- Nylon with latex backing,
- Fire retardant treated PVC with a treated backing, or



- Standard PVC with a standard backing.

There were a number of observations common to all three tests. The 'wool/nylon', 'modacrylic/nylon' and 'treated PVC fabric' passed all three tests. The fabrics formed a char layer when burnt, limiting the involvement of the foam and much of the cover fabric. The 'nylon' fabric and the 'standard PVC' fabric specimens failed all three tests. The 'nylon' fabric had a slow growth rate, however it did not self-extinguish and eventually led to foam involvement and a more serious fire. The results of this investigation showed that in these cases the different test methods were comparable.

### **Paul and King (1990)**

Paul & King (1990) presented the test results of a representative group of armchairs that complied with UK furniture requirements up to and including regulations made in the 1990's. The requirements of these regulations included:

- Cigarette resistant composites
- Covers resistant to matches
- Combustion Modified High-Resilience (CMHR) polyurethane foams

Tests were conducted in a brick room (3.0 m × 4.5 m × 2.5 m), with a single domestic door connecting the room to a hallway. Ceiling temperature, smoke density and volume, and concentrations of CO, CO<sub>2</sub>, O<sub>2</sub>, NO and HCN were measured and recorded. There was also an attempt to calculate the HRR from the oxygen depletion. The data was logged every 15 s.

The armchairs were constructed from a single fabric. No interliner was used. Polyurethane foam was used, with a wooden frame. There were three series of chairs built using a constant design with different fabric/foam combinations. Other chairs tested were three used chairs, taken from scrap, and three chairs of non-standard test design. The fabrics and foams used are listed below.

- Fabrics: Acrylic pile, woven cotton, woven fire retardant cotton, woven cotton/ wool, viscose pile, or woven polypropylene.
- Foam: Standard polyurethane foam, high-resilience (HR) polyurethane foam, medium density CMHR polyurethane foam or high density CMHR polyurethane foam.

The test set was relatively small (18 chairs), with no replicate test performed, so the repeatability of the results is uncertain. No detailed descriptions of the chairs tested were reported.

A gas flame specified by BS5852: Part 1 - ignition source 1, was used for most tests, since it readily ignited most of the composites in small-scale tests. Three other ignition sources, which increased in duration and theoretical heat of combustion, were also tested. It is assumed that these were BS5852:

Part 1 - ignition sources 4, 5 and 7. The chairs were ignited at the seat/back junction or the seat/back/arm junction.

The results indicated that the chairs burned in a similar manner, independent of fabric, when made with standard or HR polyurethane foam. The 'polypropylene' and 'acrylic' fabrics burned rapidly and split open early, allowing the foam to burn directly. The other fabrics ('wool', 'cotton' and 'viscose') charred and burned more slowly, exposing the foam only after the charred fabric split open. The chairs containing the HR foam burned more slowly than the standard foam, however the difference was small (1 -2 min), which would result in an insignificant advantage in a real fire. However HR foam produced a higher smoke density and peak CO concentration. The used chairs, which contained standard or HR foam, had similar burning characteristics to the new chairs of similar construction.

It was found that when 'acrylic' fabric was used in combination with the medium density CMHR foam, the chair had a similar burning profile to the chairs containing standard and HR foam, with a slight delay reaching the peak HRR. The 'cotton' fabric over the standard and HR foams produced similar results to the acrylic fabric with the high density CMHR foam. A 'cotton' fabric in combination with the high density CMHR foam did not sustain burning with the small gas flame ignition source. When fire retardant fabrics were used over CMHR foams, the smaller ignition sources could not sustain burning. The larger sources caused slow flame spread over the surface of the chair, delaying the onset of rapid burning. The fire then burned steadily, until, it was thought, the foam melted and created a secondary fire under the chair. However this was not observed during the experiments. Rapid burning then occurred destroying the chair.

### **Ohlemiller and Villa**

Ohlemiller & Villa (1992), summarised the findings from a previous study (Ohlemiller & Villa (1990). TB 133 tested the flammability of seating, and Ohlemiller and Villa investigated the reproducibility of the ignition source used and compared it with a gas burner that had a similar heat flux pattern. Mock-up and full-scale tests were performed in the furniture calorimeter. The materials used were:

- Fabrics: polyolefin, nylon, wool and PVC.
- Interliner: fibreglass.
- Foam: melamine-treated polyurethane and TB 117 polyurethane foam.

Seven combinations of fabrics and foams were used in the chair mock-ups. These did not include the use of polyolefin or PVC, the most flammable and least flammable fabrics, respectively. Cushions were assembled according to TB 133. To test for repeatability, each ignition source was tested twice. Therefore four mock-ups were made of each of the different combinations. The full-scale chairs were constructed out of solid hardwood frames. Ten 'fabric/interliner/foam' combinations were tested. No

batting wraps were used in any of the chairs. In some cases, no interliner was present either. No repeats were performed for the full-scale tests. The configuration of the full-scale chair is shown in Figure 3-8.

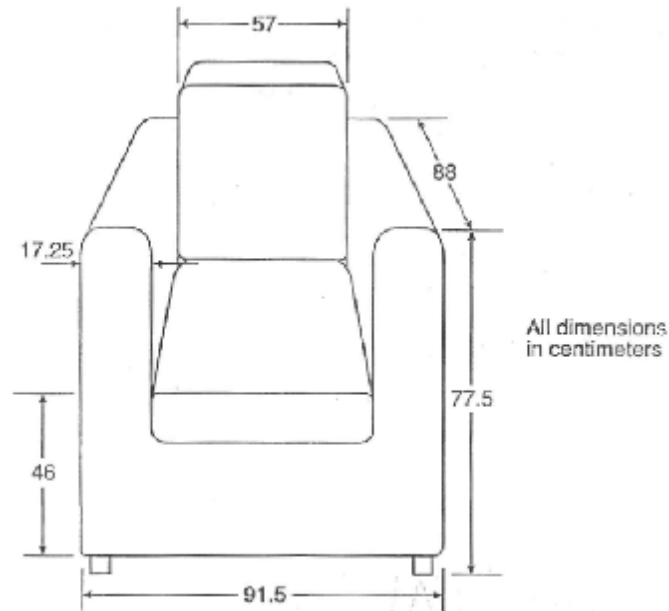

Figure 3-8: Configuration of the full-scale chairs. Extracted from Ohlemiller & Villa (1992)

The two main differences between the mock-ups and the chairs were:

- The width of the mock-up seat was appreciably larger than the full-scale chair (70 cm and 57 cm, respectively).
- The cushions used in the mock-ups left part of the back of the foam block exposed. Whereas all foam surfaces on the full-scale chairs were fully encased by the 'fabric/interliner'.

The first ignition source (TB 133) was five sheets of crumpled newsprint covered by a sheet metal/wire mesh box, as shown in Figure 3-9. This was centred between the arms on the seat, offset approximately 25 mm from the chair back. The paper was ignited by a match and burned for approximately 7 minutes, with approximately 2 minutes of flaming combustion and approximately 5 minutes of smouldering. The second ignition source was a propane gas torch, mimicking the first source by producing a comparable heat flux on the back and sides of an inert mock-up.

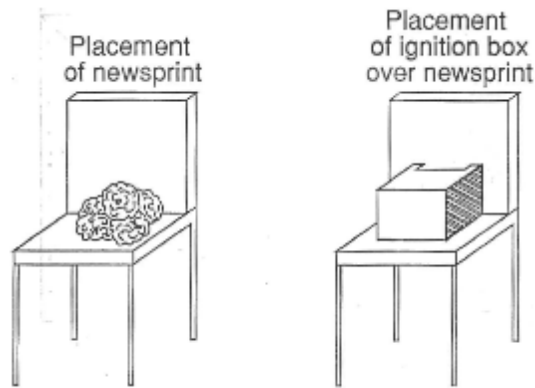

Figure 3-9: TB 133 Ignition Source 1. Extracted from Ohlemiller & Villa (1992).

The mock-up results were compared to the full-scale results. The results associated with the two ignition sources used were also compared. The chairs and mock-ups have been described as 'fabric/interliner/foam' combinations. The results for the 'nylon-/melamine' combination showed a noticeable difference between ignition sources in mock-up form, but similar performance in the full-scale test. In contrast, 'nylon/fibreglass/TB 117' produced comparable results between the two ignition sources in the mock-ups, but the results varied in the full-scale tests. Late fires developed in the 'PVC-/melamine' mock-ups, which did not occur in the full-scale tests. It was suggested that the late fire was due to the exposed cushion back present in the mock-up configuration.

The following combinations had comparable results for the two ignition sources in the full-scale tests:

- 'wool-/TB117'.
- 'nylon-/TB117'.
- 'nylon-/melamine'.
- 'polyolefin-/TB117'.

These combinations ignited early and had low fire resistance resulting in rapid flame spread. Peak HRR values exceeded 1 MW and there was high mass loss. The 'nylon-/melamine' combination was a slow developing fire, delaying the time to peak HRR. Both ignition sources on the 'wool/fibreglass/TB117' combination resulted in insignificant fire development.

For both ignition sources, the 'polyolefin/fibreglass/TB117' combination resulted in a late developing fire. However the peak HRR and the time to peak HRR depended on the ignition source. Ohlemiller & Villa (1990) suggested the two ignition sources are comparable due to the randomness of late developing fires. The 'PVC-/TB117' combination generated a late developing fire with the TB 133 source, but minimal burning when exposed to the gas burner. The difference between the results for the different ignition sources for the 'nylon/fibreglass/TB117' combination was attributed to the variability of the

TB 133 source. The 'Nylon/fibreglass/melamine' and 'PVC/-melamine' combinations resulted in weak fires, with noticeable differences between ignition sources. The 'nylon/fibreglass/melamine' combination was the only full-scale test in which the gas burner produced a more severe fire than the TB 133 ignition source. It was concluded that this was not a consequence of the material combination but of the variability inherent in the TB 133 ignition source. The reduced severity was due to one arm of the chair failing to ignite, compared to the gas burner which ignited both arms of the chair.

The fibreglass interliners significantly reduced the fire severity. The TB 117 foam produced a more severe fire than the melamine treated foam. The fabrics in increasing order of flammability were:

- PVC
- wool
- nylon
- polyolefin

The flammability of the combinations was dependant on the interactions between all three components. The combinations containing interliners were the least flammable, with the exception of the 'PVC/-melamine' combination, which had low flammability without an interliner. The combinations without interliners were more flammable and were dependant on the flammability of the fabric and then the foam. The nature of the TB 133 ignition source meant variability of results was inevitable and repeats of the full-scale tests may be necessary to determine whether the HRR profiles are typical of the material combinations. The gas burner was a more repeatable ignition source, however these experiments found it resulted in fires that were less severe compared to TB 133. The gas burner was also a less realistic ignition source when considering design fires for residential buildings. However when the chair materials ignited early and had low resistance to flame spread the results from the two ignition sources were similar.

### **Ohlemiller and Shields (1995)**

Ohlemiller & Shields (1995) tested 27 full-scale fabric/interliner/foam mock-ups. The configuration of the mock-up is shown below in Figure 3-10, using TB 133 to investigate the effects of different fabrics and barriers. A number of cone calorimeter tests were also conducted, however they are not relevant to this review. The full-scale mock-up tests were conducted in a furniture calorimeter. The HRR and heat flux were measured and camera observations were taken for each test.

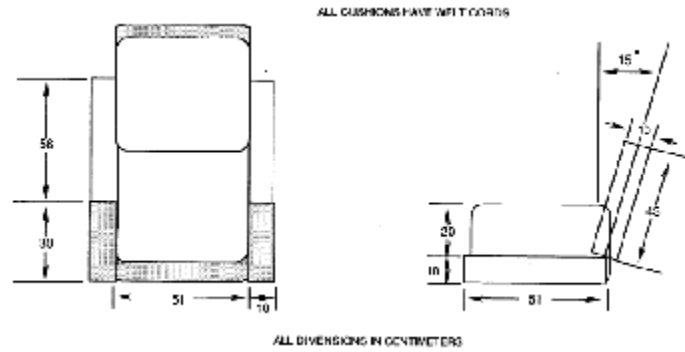

Figure 3-10: Mock-up configuration. Extracted from Ohlemiller & Shields (1995).

The cushions were attached to a steel frame, with a steel mesh under the arm cushions to prevent them falling off the frame. The cushions were constructed with a fabric cover/interliner/foam padding. The materials used are shown below:

- Fabrics: Polyester, nylon, cotton, 2 densities of polypropylene, 2 densities of polypropylene with fire retardant backcoat, 75% / 25% modacrylic/ nylon, or 62% / 38% cotton/ polyester.
- Interliner: Aramid fibre, knitted glass/ charred fibre, knitted glass/ charred fibre embedded with halogen fire retardant resin, or fibreglass.
- Foam: Melamine-treated polyurethane or Cal 117 polyurethane foam

Initial samples were made with nylon zippers however these failed during testing, prematurely exposing the foam. In subsequent samples, the cushions were sewn closed to prevent this type of failure. The ignition source was a square-ring propane gas burner, which was positioned so it did not touch any of the surfaces. It was located on the centre line of the seat cushion offset from the back cushion.

The test results showed that there were often two peaks in the HRR, the first occurring while the burner was still on. The second, often larger, peak occurred once the burner was extinguished. With the exception of the polypropylene fabrics, the first peak appeared to be more dependent on the cover fabric than the interliner. With increasing HRR ranging from 40 kW to 180 kW, the fabrics were modacrylic/nylon, cotton, polyester, polyester/cotton, and nylon. The interliners with the polypropylene fabrics interacted differently depending on the combination. The peak HRR varied from 80 kW to 240 kW.

The camera observations showed that typical flaming started at the seat back and on the seat cushion, below the burner. From there, the flaming area increased rapidly. The thermoplastic fabrics (for example, nylon and polyester) curled back from the flames eventually melting and dripping off the cushions or forming small pool fires, exposing the materials underneath. The cotton fabric formed a char layer, which split while the burner was still on, exposing the material underneath.

Once the burner was extinguished, most of the sample continued to burn with flames spreading along the crevices between the cushions. For the mock-ups made with modacrylic /nylon covers and interliners, the first peak HRR was greater than the second peak. The cotton and polyester cover with the knitted glass or the fibre glass interliners did not have a secondary peak HRR. With the aramid fibre interliner, the second peak HRR for the cotton and polyester fabric covers was limited to less than 120 kW. The polyester and nylon fabric covers did not show a second peak with the fibre glass interliners, but a significantly higher second peak occurred when the other interliners were used (over 350 kW and 450 kW, respectively). The polypropylene fabric showed a high second peak HRR (200 kW – 750 kW), regardless of the interliner used. The exception being the knitted glass/charred fibre embedded with halogen fire retardant resin interliner, where the second peak HRR was consistently less than 80 kW. The high density polypropylene with fire retardant backing over the melamine foam also controlled the HRR to less than 80 kW, once the burner was extinguished.

The test found that interliner failure was due to the melting of the foam. In these cases, the heat transfer through the cushion was sufficient to melt the foam. The melted foam seeped through the pores of the interliner. The melted foam could then ignite, increasing the HRR, which in turn melted more foam, while the interliner remained intact. In some cases, the heat transfer was sufficient to ignite the foam within the interliner without causing it to break. A single test was performed using a two cushion mock-up, which removed a major source of radiation feedback (the armrests). This produced a significant reduction in HRR and chair involvement, showing radiation feedback as a major contribution to the burning characteristics of an upholstered item.

### **Nurbakhsh et al. (1991)**

Nurbakhsh et al. (1991) summarised a previous report (Nurbakhsh (1991)). The test results of full-scale upholstered chairs in three different test locations were compared. Ten sets of upholstered chairs were tested in the California Bureau of Home Furnishings (CBHF) test room, ASTM room and furniture calorimeter. The instrumentation was identical in each room. Measurements were recorded for CO concentrations, temperature rise, heat flux, smoke opacity, weight loss and HRR.

The chair design and ignition sources were the same as that used by Ohlemiller & Villa (1990). In total 70 chairs were obtained, of which 55 were tested. These chairs were made of various fabric/interliner/foam combinations. The materials used are shown below:

- Fabrics: wool, nylon, PVC, vinyl, or polyolefin.
- Interliner: fibreglass.
- Foam: melamine-treated polyurethane, or TB117.

The ignition sources used were crumpled newspaper (TB 133) and the equivalent gas burner.

During testing, four of the chairs were excluded from the CBHF room tests due to the possibility of flashover, which was beyond the safety margin of the room. The excluded chairs were the 'wool-/TB117', 'nylon-/TB117', 'nylon-/melamine', and 'polyolefin-/TB117' combinations. In the ASTM room, the chairs were ignited by the newspaper (TB 133). In the furniture calorimeter, each chair was ignited by the newspaper, then the tests were repeated using the gas burner. In the CBHF room, both ignition sources were used and tests were conducted with each ignition source, for comparison. A single test was conducted with a 'nylon-/TB117' chair in the CBHF room using the newspaper ignition source. The resulting fire exceeded the capabilities of the exhaust system. Mass loss rate, temperature, CO concentration and HRR measured in the ASTM room tests were compared to the results in the CBHF room. The results were comparable when equivalent chairs tested.

Figure 3-11 shows the HRR curves for the 'nylon/fibreglass/TB117'. It is typical of the HRR curves produced by most of the chairs in the three testing facilities. There are two peaks, which have been identified. The first dominated by the burning fabric and the second larger peak dominated by the foam.

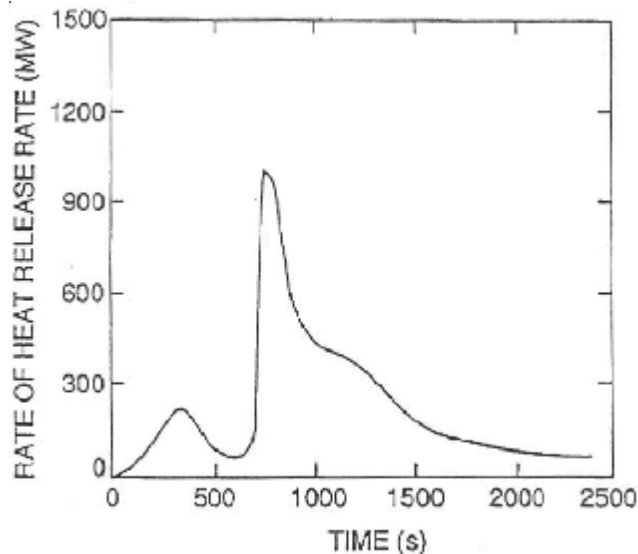

Figure 3-11: The HRR curve for a 'nylon/fibreglass/TB117' combination chair.  
Extracted from Nurbakhsh (1991).

The first peak was similar in magnitude in the two test rooms; however the second larger peak was significantly higher in the ASTM room. The radiation feedback present in the ATSM room accounted for the enhanced HRR. Overall, the tests found that when the peak HRR was below 600 kW there were no



significant compartment effects. This condition may not be true for smaller rooms or rooms with low thermal conductivity.

### 3.1.4 Influence of Ignition Source

#### **McCormack et al.**

California has a number of regulations regarding the flammability of upholstered furniture sold within the state. The furniture was tested using TB116 and TB117. "TB116 is a voluntary standard which tests the whole furniture item for total resistance of cigarette ignition. TB117 is the mandatory standard involving small-scale tests of the filling/ stuffing materials requiring both flame retardancy and smoulder resistance." (Damant et al. (1983) There is ongoing testing of furniture manufactured within California and furniture imported into the state to ensure compliance. Imported items are tested by purchasing items at random from retail outlets, items range in price, construction, materials and origin. Damant et al. (1983) published findings for 171 furniture items. McCormack et al. (1986) discussed the propensity to cigarette ignition of 450 items including those tested. McCormack et al. (1988) presented results from furniture purchased from 1986 to 1988 and included the findings from 1981-1986. The total number of chairs tested was 700 of which 679 were tested using TB 116.

The 450 chairs investigated by McCormack et al. (1986), purchased between 1981 and 1986, were manufactured in the USA. The foams used in the furniture varied from those which complied with TB 117 to those that either failed or had not been tested. The variety of padding materials tested included:

- Shredded polyurethane foam,
- polyurethane foam pads,
- Cotton batting,
- Cellulose pads, and
- Synthetic fibre and cotton mixed batting and pads.

A few chairs containing hair or vegetable fibre were tested. However as chairs made of these padding materials are rarely available, the results were disregarded and removed from the data set.

The chairs purchased from 1986 to 1988 (McCormack et al. (1988) were manufactured in Europe (Italy, Denmark, Norway, Belgium, Romania), Asia (Taiwan) and Canada. The designs varied from dining room chairs, office chairs, recliners, bar stools and armchairs. The majority of the chairs contained some polyurethane foam. Cover fabrics were identified as 100% cellulosic (89 chairs), 100% thermoplastic (256 chairs), blends (295 chairs), and leather (39 chairs). The fabrics were grouped into cellulosic fabrics and thermoplastic fabrics.

- Cellulosic: cotton, rayon and linen.
- Thermoplastic: acrylic, polyester, PVC, nylon, polypropylene, acetate, wool, and silk.

The ignition source for TB 116 was a cigarette placed under a 152 mm x 152 mm square of cotton sheeting. The cigarettes were placed on the chair at one or more of the following locations (as shown in Figure 3-12):

- top of the back,
- tuft,
- seat/ back crevice,
- seat/ arm crevice,
- top of arm,
- quilting welt cord,
- decking (seat platform),
- footrest,
- headrest, and/or
- seat

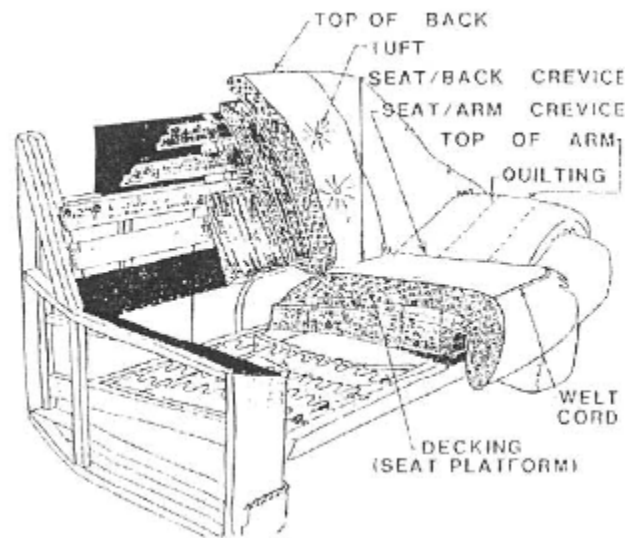

Figure 3-12: Locations of ignition used for the testing of various chairs.  
Extracted from McCormack et al. (1988).

A chair was considered to have ignited if the char spread more than 50.8 mm from the cigarette in any direction.

Of the 700 chairs tested 480 did not ignite from any of the cigarettes, the remaining chairs had ignition at 1, 2 or 3 of the ignition locations listed above. A summary of the relevant conclusions of the study results include (McCormack et al. (1988):

- The most vulnerable ignition location for an upholstered chair was at a crevice and along the welt cord.
- The fabric used influenced the ignitability of the chair by cigarettes.
- The susceptibility to cigarette ignition appeared to relate to the cellulosic content of the chair.
  - Chairs, which had 100% thermoplastic fabric covers, were the most resistant to smouldering, 31 of the 256 chairs smouldered.

- Chairs, which had 100% cellulosic fabric covers, were the least resistant to smouldering, 60 of the 89 chairs smouldered.
- Only two of the leather covered chairs smouldered.
- Heavier fabrics were more likely to ignite and smoulder than lighter weight fabrics.
- The probability that smouldering would occur increased as the cellulosic content of the fabric increased.
- Smouldering cigarette ignition was most likely to occur in the crevice area of an upholstered chair with a heavy-weight fabric 100% cellulosic cover with cotton batting directly beneath the fabric and no resin back coating was present

### **Cleary et al. (1994)**

Cleary, T. G. et al. (1994) investigated the influence of ignition sources on the flaming fire hazard of upholstered furniture. The tests were carried out in a furniture calorimeter using the same full-scale chair as Ohlemiller & Villa (1992). Five different fabrics were used to cover conventional non-fire retardant polyurethane foam, these are described below:

- Cotton, non fire retardant cotton batting.
- 63% nylon/26% olefin/11% acrylic with latex backing.
- 100% olefin, latex backing.
- Acrylic, rayon/cotton backing.
- Expanded vinyl.

There were five ignition sources tested: a cigarette, match sized flame, incandescent lamp, space heater and a large flaming source. An 85 cm non-filtered cigarette, which had burned for 2 minutes, was placed in the same position as the match flame and was not removed for the duration of the test. The match flame was simulated using a small propane gas burner. An established flame was placed in the crevice of the seat and the arm cushions for 20 s and then removed. The incandescent lamp was a 55 W quartz-halogen lamp with a typical desk lamp fixture to simulate a reading lamp. It was placed near the corner of the chair on the seat and then tipped on to the chair arm, so the bulb was 5 cm from the covering fabric. An electric spark at 10 s intervals tested the ignitability of the pyrolysed material. The large flaming source was the gas burner characterised by Ohlemiller and Villa Ohlemiller & Villa (1992) centred between the arms, on the seat, offset from the back cushion by 25 mm. The space heater was initially placed with the front grill 10 cm from the front of the seat. It was eventually tipped so the grill touched the front of the seat cushion. An electric spark was used in the same manner to test for pyrolysed material, as had been used for the lamp.

HRR rates and combustion gas species were recorded for each test, however it appears only the peak HRR and time to peak HRR were published. Detailed results of the HRR profiles, mass loss rates,

concentrations of CO and CO<sub>2</sub>, and smoke yields are given in Cleary, T. et al. (1992). Time,  $t = 0$  s, was taken as the time when flaming combustion began. When sustained burning was achieved, a replicate test was performed. These repeats produced similar ignition behaviour.

The cotton/non-fire retardant cotton batting chair was the only chair to ignite from the cigarette, after smouldering for approximately 3 hours. However the same cover did not ignite with the lamp or match ignition source. The peak HRR varied from 400 kW – 500 kW, with the time to peak varying from 1000 s – 2200 s. The '63% /26% /11% nylon/ olefin/ acrylic with latex backing' chair and the '100% olefin with latex backing' chair did not produce sustained burning from the lamp or cigarette ignition source. The peak HRR was 1000 kW – 1500 kW and time to peak was 300 s – 600 s, and 800 kW – 1200 kW and 250 s – 550 s, respectively. The '100% olefin' chair test was repeated seven times with the match ignition source, but only developed into flaming combustion during one of the tests. The 'acrylic with rayon/cotton backing' chair burned for all ignition sources, except the cigarette, with a peak HRR 900 kW – 1300 kW in a time of 150 s – 950 s.

When sustained burning was achieved, the peak HRR for each type of chair was independent of the ignition source. However, the time to peak HRR varied considerably (up to 1500 s), depending on ignition source. The larger ignition sources (the gas burner and space heater) resulted in sustained burning for all chairs.

### **Söderbom et al. (1996)**

The influence on the size of the ignition source of the burning characteristics of items in the furniture calorimeter was investigated by Söderbom et al. (1996). All the HRR profiles start (at time,  $t = 0$  s) at the point where the HRR reaches 50 kW. Two sets of experiments were discussed. The first experiments were conducted earlier by the University of Gent. In these experiments, two types of armchair were tested:

- An armchair constructed with a solid beech frame, '65 % – 35 %, acrylic – viscose/polyether fibre/polyether foam (27.5 kg.m<sup>-3</sup> & 17 kg.m<sup>-3</sup>)', and
- A fire retardant (fire retardant) armchair constructed with a solid beech frame with wooden laths, '69 % – 31 % acrylic – cotton/polyester fibre/CMHR foam (37kg.m<sup>-3</sup>and 35 kg.m<sup>-3</sup>)'.

The ignition source was a square gas burner set at four different intensities:

- 40 kW for 120 s,
- 30 kW for 120 s,
- 30 kW for 180 s, and
- 20 kW for 300 s.

The results showed there was no significant difference between the ignition sources. The armchair had a peak HRR ranging from 463 kW – 511 kW after 150 s – 200 s. The fire had a growth rate similar to a  $t^2$ -fire. The fire retardant armchair had higher peak HRR values, ranging from 918 kW to 1182 kW. However the peak was reached later (300 s – 400 s) and there was a period of steady burning at approximately 20 kW before the fire rapidly grew to its peak HRR.

The second set of experiments used six different armchairs available commercially on the European market. All chairs had upholstered armrests and had the following combinations of materials:

- Acrylic with fire retardant backcoat/fire retardant polyester/CMHR seat – fire retardant polyester back.
- Leather/-/HR foam.
- Polyester/polyester fibre/polyether foam.
- Fire retardant treated cotton/fire retardant polyester fibre/CMHR foam.
- Polyester/polyester fibre/polyether foam.
- Fire retardant polyester/-/HR foam.

Lower ignition sources were used for this series of experiments, by using a smaller gas burner. The heat outputs used were:

- 1.7 kW for 90 s
- 5.8 kW for 90 s
- 30 kW for 120 s

If the item did not ignite with the 1.7 kW ignition source, then the heat output was increased to 5.8 kW and applied for a further 90 s. Initial match sized flame tests were also conducted to ensure the furniture encompassed a large range of fire resistance. The first four items did not ignite using the smallest ignition source. However the 'polyester/polyester fibre/polyether foam' armchair ignited with the smaller match sized flame. This was thought to be due to the local geometry of the chair at the location where the burner was applied. The other two items ignited when the 1.7 kW source was used, so the 5.8 kW source was not applied.

The 'acrylic with fire retardant backcoat/fire retardant polyester/CMHR seat – fire retardant polyester' armchair had the best performance. It did not ignite with the 1.7 kW or the 5.8 kW ignition sources. The growth rate was slow when the 30 kW ignition source was used and the peak HRR was relatively low, 730 kW, compared to the other armchairs. The 'fire retardant treated cotton/fire retardant polyester fibre/CMHR foam' armchair had a steady state burning (less than 150 kW for over 1000 s), before rapid fire growth to its peak HRR. The HRR of other armchairs grew rapidly to peaks exceeding 1000 kW.

Once the results were shifted, so  $t = 0$  s was associated with the HRR reaching 50 kW, comparison of results indicated that the growth rate and the peak HRR were very similar for both ignition sources. These results showed that if the ignition source was sufficient to ignite the item, then the size of the ignition source did not significantly affect the HRR profile of an item.

### 3.1.5 Toxicity

#### Kallonen et al. (1985)

Most of the published results from tests do not report the concentrations of the combustion gases. Kallonen et al. (1985) conducted toxicity tests for 11 cover fabrics and 6 foams/fillings. The materials were tested under temperature conditions at approximately 500°C and 700°C. Rats were used for an indication of tenability. The chemical composition the combustion products was also measured. The components measured were CO, HCN, CO<sub>2</sub>, O<sub>2</sub> and HCl. The fabrics and fillings tested were widely used commercially and often tested in upholstered furniture tests, as presented in Table 3-2.

Table 3-2: Fabrics and Foam/Fillings tested by Kallonen et al. (1985).

Fabrics	Foams/Fillings
Modacrylic	fire retardant polyester fibrefill
Wool	neoprene foam
fire retardant cotton 1	HR polyurethane foam
fire retardant viscose	fire retardant polyurethane foam
fire retardant cotton 2	flame laminated polyurethane foam
fire retardant cotton/viscose blend	standard polyurethane foam
fire retardant cotton 3	
PVA/ PVC	
fire retardant polyester	
Cotton	
waterproofed cotton	

Extracted from Kallonen et al. (1985)

Kallonen et al. (1985) presented a detailed analysis of the combustion gases of wool, modacrylic, polyester fabric and fire retardant polyester fibrefill; however this is not discussed in this review. From the toxicity tests, it was found that HCN and CO were the main cause of toxicity. The chemical analysis of the materials found that in the non-flaming tests the CO, CO<sub>2</sub>, and O<sub>2</sub> were essentially constant for the duration of the toxicity tests (30 minutes). More CO<sub>2</sub> was produced at 700°C compared with 500°C.

The fire retardant cottons produced more CO than the untreated cotton. In the untreated and treated case, the CO concentrations increased at the higher temperature, but the waterproofed cotton showed no change at the two test temperatures. At 700°C, the following materials produced lethal concentrations of CO: fire retardant viscose, two of the fire retardant cottons and the fire retardant cotton/viscose blend. HCN was produced when the materials or the fire retardant treatment contained nitrogen. At both temperatures, lethal concentrations of HCN were produced with the modacrylic, wool, one of the fire retardant cottons and the polyester fibrefill. The following materials produced high concentrations of HCl for at least one of the test temperatures: PVA/PVC, modacrylic and neoprene. The concentrations of HCl were greater than 1000 ppm, but were not lethal to the experimental animals.

In general, the materials became more toxic as the temperature increased. The health of the test animals indicated that exposure to the hot gases at the higher temperature (700°C) resulted in death during the exposure. At 500°C, test animals deaths also occurred up to one week after the exposure. The most toxic materials tested at 500°C, in order of decreasing toxicity, were:

- modacrylic,
- fire retardant cotton, then
- fire retardant polyester fibrefill.

The most toxic materials tested at 700 °C, in decreasing toxicity, were:

- modacrylic,
- wool,
- fire retardant cotton,
- fire retardant viscose, then
- fire retardant polyester fibrefill.

### **Andersson et al. (2004)**

Andersson, P. et al. (2004) presented a summary of results from the Fire Life Cycle Assessment (LCA) Model study for a furniture case study. The study was part of a larger study that was initiated in 1995 to determine the environmental impact of methods used to improve fire safety. To obtain the inputs for the Fire LCA model, one non-fire retardant sofa and two fire retardant sofas were tested in an ISO 9705 room. The HRR was measure in each test as well as the yields of:

- Inorganic compounds: CO<sub>2</sub>, CO, HCN, HCl, NH<sub>3</sub>, NO, Sb, Br and P,
- Volatile Organic Compounds (VOCs); 10 different compounds,
- Polybromide diphenyl ethers (PBDE); 8 different compounds,
- (PAHs); 20 different compounds, and
- Dioxins and Furans; 12 different groups of compounds.

The sofas were two-seaters with a wooden frame, polyurethane foam padding and cotton cover. The non-fire retardant sofa was made with standard foam and an unmodified cotton cover. Fire retardant sofa 1 was made with melamine foam and a phosphorous (P) treated fire retardant cotton cover. Fire retardant sofa 2 also had melamine foam and the cotton cover had a brominated (Br) backing coat. The ignition source for the non-fire retardant sofa was a utility lighter. The fire retardant sofas were ignited using a 30 kW burner initially in one corner of the sofa for 10 minutes and then the opposite corner for 5 minutes.

The peak HRR for all the sofas tested was 690 kW – 750 kW. Fire retardant sofa 2, treated with bromide, was the only one that produced detectable levels of HCN. This was probably due to the Br inhibiting combustion, thereby promoting the formation of HCN. There were significant concentrations of HCl produced by the non-fire retardant sofa. The source of Cl was found to be the adhesive used on the sofa. Tests found Br in the combustion gases of all three sofas. For the non-fire retardant sofa and the fire retardant sofa 1 (P treated), the only possible source of Br was from impurities in the foam. Br inhibits combustion, so a high concentration of chlorinated dioxins/furans was found in the combustion gases of fire retardant sofa 2. Also due to the Br in fire retardant sofa 2, significant concentrations of PBDEs and brominated dioxins/furans were produced.

### **3.1.6 Interliners**

#### **Gallagher (1993)**

Gallagher (1993) studied the effect of an interliner on the burning behaviour of upholstered materials. Small-scale tests were conducted on various 'fabric/interliner/foam' samples. Two foams were looked at: a polyurethane foam that complied with TB 117, and a melamine modified foam that complied with TB 133 (a more stringent standard). The materials used for the covers and interliners were:

- Fabric: Nylon A, nylon B, polypropylene (7.7 oz/yd<sup>2</sup>, 8.23 oz/yd<sup>2</sup>, 13.1 oz/yd<sup>2</sup>), or cotton (8 oz/yd<sup>2</sup>, 16 oz/yd<sup>2</sup>).
- Interliner: None, glass cloth, Kevlar, polyester batting, or cotton batting.

A heat flux of 1.0 W/cm<sup>2</sup> was applied to the samples within a calorimeter (ASTM E 906). The pilot flame was extinguished after 80 s.

The results of these tests showed that the behaviour of a sample was dependant on the combination of the materials such that the performance of an upholstered item can not be accurately predicted using individual component tests. For example, the nylon fabric samples showed no significant differences between the two fabrics and, as expected, the heat released from the 'nylon-/Cal 117' was considerably more than the 'nylon-/Cal 133' sample. However when a glass cloth interliner was included in the sample the heat released from the Cal 117 and Cal 133 samples was remarkably similar. The interliner



in the 'nylon/glass cloth/Cal 117' samples acted as a thermal barrier decreasing the heat released. Conversely the interliner in the 'nylon/glass cloth/Cal 133' samples appeared to form a heat trap causing the Cal 133 foam to melt and char under the interliner, increasing the heat released. The polypropylene sample showed the same behaviour as the nylon samples. When the interliner was present in the polypropylene samples, the peak heat release was proportional to the weight of the fabric. In the cotton samples, the glass cloth interliners resulted in a decrease in total heat released. Without the interliners, the burning behaviour of the cotton samples appeared to change, due to the depletion of melamine in the foam the flaming characteristics changed to a more sustainable burning and the levels of smoke produced reduced.

The Kevlar interliner produced similar burning behaviour to the glass cloth. The polyester and cotton batting, when used in combination with melting fabrics, appeared to exacerbate burning behaviour. The melting material absorbed into the upper layer of the batting, allowing it to burn more readily. In general, these tests showed the fire performance was improved with the interliner when the Cal 117 foam was used. However the performance deteriorated when the glass cloth interliner was used in conjunction with the Cal 133 foam.

### **3.1.7 Other Design Features**

#### **Trimmings**

D'Silva & Sorensen (1996b) investigated the flammability of decorative trimmings on upholstered furniture. The experimental results indicated cellulosic trimmings had a tendency to smoulder, which could lead to progressive smouldering of the upholstered furniture. However trimmings that were made from fire retardant materials continued to have good fire resistance. The trimmings on an upholstered item contributed insignificantly to the total fuel, therefore having a negligible effect on the burning characteristics of an item. However, depending on the materials used as trimmings, they could act as a secondary ignition source, increasing the ignitability of the item. While developing a new method to test trimming flammability, D'Silva (1998) found the flame spread was dependant on the fibre type and the angle of the trimming from the ignition source. Furthermore, ignition of an upholstered item from the flaming trimming depended on the trimming material and the cover fabric.

#### **Soiled and Unsoiled Fabrics**

Only a few fire tests have been conducted on used furniture, so the fire performance of used furniture in general is unclear. (Wanna et al. (1996a); Wanna et al. (1996b) conducted two studies into the smouldering potential of unsoiled and soiled upholstery fabrics and then characterised the behaviour. The first study looked at fabric obtained from 60 used chairs; armchairs, recliners, sofas etc. from stores around Richmond, Virginia, USA. The average age of the chairs was 15 years. The second study was conducted with a similar sample size in the state of Georgia. Samples (127 mm square) were taken

from each chair, representing both unsoiled and soiled fabric. The unsoiled samples were taken from the underside of cushions and from deep crevices. The soiled samples were from the tops of the cushions and the arm rests. The fabrics were divided into three categories: cellulosic, synthetic and cellulosic/synthetic blends.

The smouldering potential was tested using a 3 second exposure to a small butane flame. Ignition was considered possible if the fabric continued to smoulder for over 2 minutes after the flame was removed. The flaming combustion generated with the synthetic fabrics was blown out, allowing the smouldering potential to be studied. Five repeat tests were conducted for each sample.

Increasing smouldering potential due to oil stains was not considered in these studies. Quantities of sodium and potassium ions in the fabrics were measured. These were indications of how much sweat had been absorbed into the fabric. The highest sodium and potassium ion concentrations were found on the arm rests of the chairs. Other species measured were calcium, magnesium, and six different anions including chloride and sulphur. None of the synthetic fabrics smouldered once the flames were extinguished. The material melted, curled and blackened. Overall, findings in both studies indicated that soiling did not increase smouldering potential. Depending on the nature of the soiling, the smouldering potential was even observed to decrease, particularly if the sulphate anion concentration was high.

### **3.2 Literature Summary of Upholstered Furniture Fires**

- Easy chairs can contain enough combustible mass to cause flashover in a room even in isolation. Lawson, J. R. W. et al. (1984)
- Ignition of upholstered furniture is more difficult if the item contains wooden panels within its frame and the ignition source is located at these sites. Lawson, J. R. W. et al. (1984)
- In general it is found easy chairs and loveseats with rapid fire growth rates have one distinct peak HRR. Lawson, J. R. W. et al. (1984)
- Office chairs have lower peak HRR as they contain significantly less combustible materials. Lawson, J. R. W. et al. (1984)
- Arms on upholstered items increase the HRR and fire growth rate; this is caused by the increase in radiation feedback on to the seat of the chair. Sundström (1994)
- Cushions supported by webbing show higher HRR and faster fire growth rates. This is due to the cushion burning through the webbing forming a pool fire inside the chair, significantly enhanced radiation feedback. Sundström (1994)
- A chair with no frame causes the most hazardous conditions, because of the large amount of combustible materials. Sundström (1994)
- The most common framing material for upholstered furniture items is wood. Sundström (1994)

- The combustible mass of the frame is inconsequential to the burning behaviour of an upholstered item in early stages of the fire, as it does not become involved until the later stages of the fire. However if the frame fails it can adversely affect the burning behaviour because large quantities of combustible material can be suddenly be exposed. Sundström (1994)
- It is generally found the correlation between an increase in peak HRRs and the size of the chair; that is between armchairs, loveseats and sofas and this correlation is greater than linear. Sundström (1994)
- In the early stages of a fire an armchair fire still represents the worst-case room scenario, this is due to greater radiation feedback effects between the item and itself, and the item and the room. Sundström (1994)
- The most vulnerable area of an upholstered seat, to cigarette ignition, is along a crevice or welt cord. McCormack et al. (1986)
- HR foam gives a higher peak CO and smoke density compared with standard PU foam Paul & King (1990)
- Where armchairs have cover fabrics which are char forming or treated with FR two peak HRR can be identified, the 1<sup>st</sup> peak is associated with the burning fabric the 2<sup>nd</sup> peak is associated with the foam. Schuhmann & Hartzell (1989)
- It has been found that peak HRR below 600 kW within a standard sized room are not appreciably affected by radiation enhancements and compartment effects. Nurbakhsh et al. (1991)
- It has been found that if an ignition source is sufficient to cause flaming combustion in an upholstered chair different sized ignition sources produce comparable peak HRR, with differing times to reach the peak. Cleary, T. G. et al. (1994)
- No matter how small the ignition source there is always some statistical probability it will ignite a larger item (e.g. an upholstered chair) leading to a sizeable fire. Cleary, T. G. et al. (1994)
- Upholstered furniture that is smouldering may have a time delay of several hours before flaming combustion initiates spontaneously. Cleary, T. G. et al. (1994)
- Preliminary experiments found that nylon zippers used on fabric covers can fail before the fabric, exposing the foam to a fire prematurely. Cleary, T. G. et al. (1994). This could severely compromise the FR of an upholstered item and change its burning behaviour.
- Cover fabrics can affect the burning behaviour of an item:
  - Cotton fabrics can char, slowing fire growth and lowering the HRR unless the char layer breaks. Krasny & Babrauskas (1984)
  - Thermoplastic fabrics tend to melt and form pool fires exposing combustible material underneath. Ohlemiller & Shields (1995)
- General observations from upholstered chair fires show flames tend to spread along the crevices. Ohlemiller & Shields (1995)

- Interliners can fail without breaking, the heat transfer through the interliner can be large enough to cause the foam to melt or even ignite. Ohlemiller & Shields (1995)
- It was found that the CBUF model was not good at predicting the burning behaviour of New Zealand furniture, the NZ furniture consistently produced higher HRRs than the model predicted. Enright et al. (2001)
- Tests monitoring combustion products found that more CO<sub>2</sub> was produced at higher temperatures, 700 °C compared with 500 °C. The study also found that FR cottons produce more CO than non FR treated. Kallonen et al. (1985)
- The most toxic cover fabrics in decreasing order at 2 different temperatures. Kallonen et al. (1985)

Temperature 500 °C	Temperature 700 °C
Modacrylic	Modacrylic
fire retardant cotton	Wool
fire retardant polyester fibrefill	fire retardant cotton
	fire retardant viscose
	fire retardant polyester fibrefill

- Trimming can increase the ignitability of upholstered items due to the trimmings increased smouldering potential. (D'Silva & Sorensen (1996a); D'Silva & Sorensen (1996b))
- Soiling of materials (excluding oils) does not increase smouldering potential of upholstered cushions. (Wanna et al. (1996a); Wanna et al. (1996b))
- In general the fire performance of an upholstered item is improved with "interliner/ Cal 117 foam" combination is used. However the performance can deteriorated when the glass cloth interliner is used in conjunction with the Cal 133 foam. Gallagher (1993)

## 4 Literature Review – Characteristic Compartment Effects

Fires in compartments can have different burning characteristics from fires in the open, therefore how a fire changes in a compartment becomes important when considering a design fire in the design fire. A fire in a compartment can quickly grow to full room involvement, where the fire rapidly grows from a single item burning to all flammable items in the room burning. This event is known as flashover there are 3 commonly used criteria to identify the occurrence of flashover in a compartment fire, the origins of which are described by Liang et al. (2002). The criteria are:

- Compartment temperatures reaching 500 °C – 600 °C
- Radiation on the compartment floor reaching 15 – 20 kW/m<sup>2</sup>
- Flames extending out of the compartment

The possibility of flashover and the time before flashover occurs is dependant on parameters of the compartment as well as the fuel characteristics. Room size, available ventilation and radiation feed back effects need to be considered when determining whether a fire will reach its peak HRR in either ventilation controlled or fuel controlled conditions. The parameters mentioned above can affect the fire characteristics including, growth rate, species production and mass loss rate. The literature reviewed focused on experimental observations, as opposed to mathematically derived compartment effects. The aspects of compartment effect of interest were how the above compartment parameters affected fire characteristics both qualitatively and quantitatively.

### 4.1 Literature Annotation

#### **Harmathy (1979)**

Harmathy (1979) looks at the effects of the fuel on the characteristics of a fully developed compartment fire. The focus of this paper was on synthetic polymers and this was compared to the behaviour of wood, which was already well studied. It was noted that the parameters which increased the severity of the fire were:

- The heat flux absorbed by the compartment boundaries.
- Duration of the fully developed fire.
- Average temperature of the gas within the compartment.

Small pool fires in well ventilated compartments show very little compartment enhancement compared to free burn fires of the same size. However, large pool fires show completely different burning characteristics in a compartment compared to free burn scenarios. In large fires the entrainment of air

into the plume is restricted to the direction of vents in the compartment. Radiation back on to the fire also increases producing high levels of volatiles.

Fuels in pile type configurations (Figure 4-1) are a more complex geometry than pool fires, the air being entrained into the fire and the volatiles produced by the fire are "primitively premixed". This creates fires with a shorter flaming period and a hotter fire than a pool fire. Harmathy (1979) notes that earlier studies show the pyrolysis rate was 3.7 – 5.4 times higher in a pile configuration compared with a slab of pool fire of the same material and base area. Though there were only a few studies in this area at the time it was found that increasing the pile density and height decreased the pyrolysis rate.

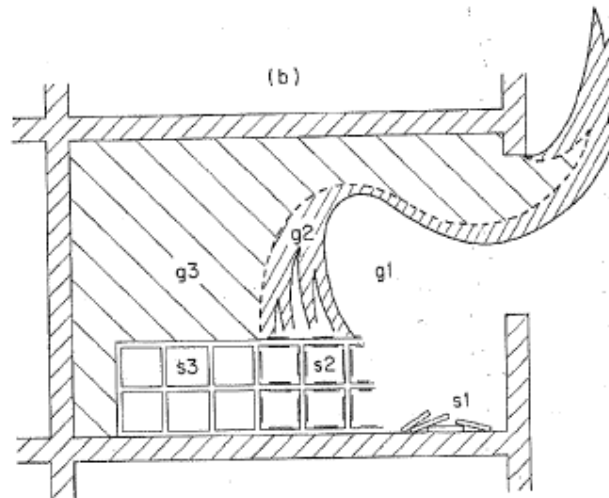

Figure 4-1: Pile Configuration of Fuel. Extracted from Harmathy (1979)

Harmathy (1979) found the following factors increased the severity of wood fires:

- Strongly dependant on the fire load, the severity of the fire increased with fire load
- Severity was highest at low ventilation and decreased severity as the ventilation conditions improved.

When the burning characteristics of synthetic polymers were compared to that of wood, it was found they gave much more severe fires. The severity of a synthetic polymer fire also increased in severity when the fuel load was increased, which was more prominent than the increase observed in wood fires.

The article suggested that items made from a mixture of cellulosic material and smaller quantities of synthetic polymers (plastics) could be characterised by a cellulosic fire with a very high growth rate superimposed in the initial period of the fire and an increase in fire spread.

## Babrauskas (1984)

Babrauskas, V. J. (1984) conducted a series of room tests and compared those previously conducted furniture calorimeter tests Babrauskas, V. (1983). The purpose of these comparisons was to investigate 3 questions;

- Is the pre-flashover HRR the same in the room tests and furniture calorimeter tests?
- How can flashover conditions be best predicted?
- Does the burning rate of the furniture item increase appreciably after flashover compared with the free burn burning rate?

The layout of the room tests can be seen in Figure 4-2. The room tests considered fuel controlled scenarios only, so none of the tests reached ventilation controlled conditions. The room was lined with gypsum with the paper burned off before the furniture tests, this was to prevent the burning paper influencing the HRR and other burning characteristics.

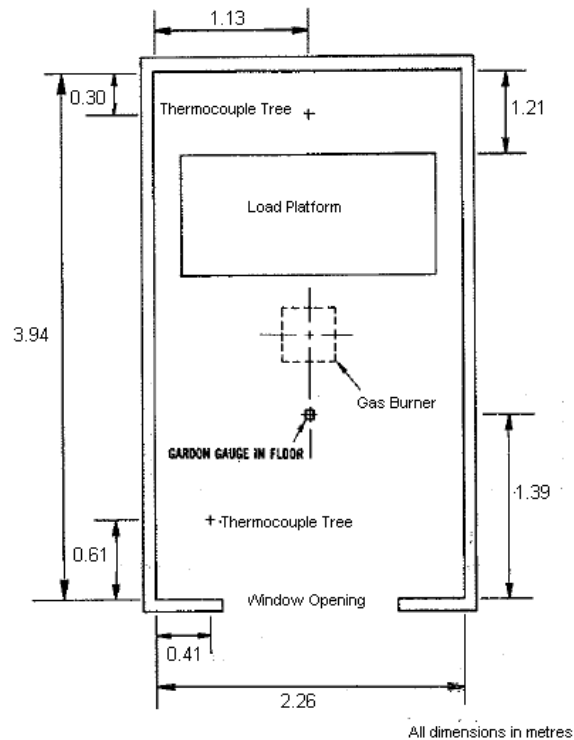

Figure 4-2: Room Configuration for Experiments. Extracted from Babrauskas (1984)

The items of furniture were an arm chair and a 2-seater sofa (loveseat), both constructed with a wooden frame, PU foam and polyolefin cover fabric. In the free burn tests the ignition source was a gas burner located by the side of the item, the HRR of the gas burner represented a burning wastepaper basket. In the room tests the ignition source was a polyethylene wastepaper basket containing 390g of milk

cartons. Four different room tests were conducted (Table 4-1) with varying ventilation conditions, the soffit height was kept constant with changing opening height and width.

Table 4-1: Description of the room tests. Extracted from Babrauskas (1984)

Test	Item	Soffit (m)	Opening	
			Width (m)	Height (m)
1	Loveseat	0.31	2.0	1.13
2	Loveseat	0.31	2.0	1.5
3	Armchair	0.31	1.29	2.0
4	Loveseat	0.31	1.29	2.0

Observations from the experiments showed unexpected behaviour around the opening. From previous predictions it was expected that the flow from the opening would be like an inverted weir. However the observed behaviour is shown below in Figure 4-3;

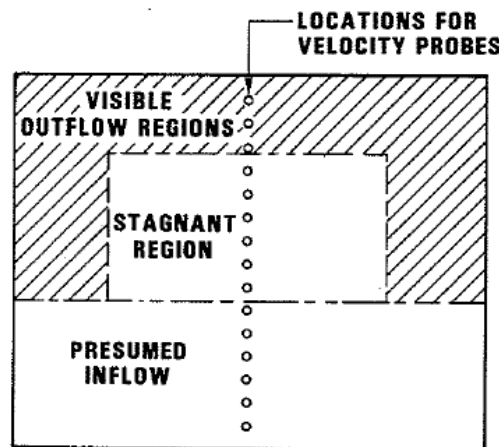

Figure 4-3: Observed air flow through the opening. Extracted from Babrauskas (1984)

All the room tests conducted were fuel controlled and did not reach flashover conditions, when compared with the free burn results it was found there was no significant enhancement due to room effects. The peak HRRs were 10% higher, however the width of the peaks were also 10% wider. The increase in width indicates the higher HRR was more likely due to experimental scatter. A narrowing of the peak HRR width would be expected when room enhancement occurred.

### **Blomqvist & Andersson (1985)**

Blomqvist & Andersson (1985) conducted full scale furniture experiments in order to compare them with zone models. The experiments consisted of 10 room tests and two free burn tests. An ISO room, which has the dimensions 2.4 m x 3.6 m x 2.4 m high, was used. The ventilation in an ISO room tests is an opening in the short wall (0.8 m x 2.0 m). The walls, floor and ceiling were constructed of concrete.



The fuel was full sized mock-ups of a 3-seater sofa, the frame was metal, and the cushions, standard PU foam with 100% acrylic cover fabric.

Data recorded in the free burn tests were, mass loss rate and HRR. In the room tests mass loss rate, HRR and two temperatures were measured. In the comparison between the free burn and room experiments it was found that in the early stages of the fire the characteristics were similar in both scenarios. The fire in the rooms' growth rate then rapidly accelerated, between 140 s and 180 s after ignition, compared to the free burn experiments. The peak HRR in the room was also noticeably higher in the room tests 1.8 MW compared with 1.2 MW in the free burn conditions.

The experimental results were compared with the zone model Harvard Mark V. In the simulations the sofa fires were represented by defining the following 4 variables:

- Initial burning radius
- Maximum burning radius
- Fire spread parameter
- Fraction of heat released

These parameters were altered in free burn simulations to give the most accurate results compared to the experiments. These values were then used in the room experiments. All other parameters were kept at the programs default values.

One of the limitations of the zone model in simulating the real fires was that in the experiments it was found that the lower layer temperature sometimes exceeded 400 °C, however in the zone model heating of the lower layer was ignored so remained at ambient temperature. As a result heat loss to the lower layer would be over estimated in the simulation resulting in a lower upper layer temperature.

### **Dembsey et al. (1995)**

Dembsey et al. (1995) 20 full scale compartment fires were compared with models of the same scenarios. The primary focus of the experiments was to look at near-field entrainment rates of large fires in small compartments. Ceiling jet temperatures (0.1 m below the ceiling) were collected, these results were analysed to show the effects of ventilation, near field entrainment and burner location. A grid of 15 thermocouples was used to measure the ceiling jet. The burner was located at the centre of the compartment or the side wall. The experiments had HRRs ranging from pre-flashover to post-flashover conditions, 330 kW – 930 kW. The average net heat flux and radiation heat flux of the upper and lower regions of the walls and the floor were estimated using the temperature histories during experiments.

On average the maximum temperature measured by the thermocouple grid was 80°C hotter when the burner was located at the side wall, compared to the centre. This was attributed to the channelling of hot gases caused by the wall. The grid also showed that the radial temperature distribution with respect to the burner was not axisymmetric at both locations. The temperatures at the back of the compartment were consistently lower than those at the front, with differing up to 180°C. With the exception of a burner located at the side wall with HRRs less than 400 kW, in those cases the back of the compartment was slightly hotter ~10°C. When the HRR was greater than 600 kW the flames impinged on the ceiling, at this stage the hottest point shifted from directly above the burner towards the door.

The effect of burner location, ventilation conditions and near-field entrainment can not be resolved by 2-layer ceiling jet models. FIRST v 1.2, CFAST v 2.1, and 2 simple correlations were used to predict the upper layer temperatures for 3 of the experiments and these were compared to the experimental results. Default values were used in the models where the inputs were unknown. CFAST predicted temperatures hotter than those found in the experiment. This was due to the enthalpy flow through the door in the CFAST model exceeding the maximum enthalpy flow found in the experiments. The thermal properties of the walls did not appear to influence the results. CFAST results were very conservative; they suggested incipient flashover conditions when there was a 330 kW burner, none were visible in the corresponding experiment. The FIRST models consistently predicted upper layer temperatures lower than those found experimentally, 70°C to 240°C. In the FIRST model the floor and lower wall temperatures were kept at ambient temperature. The 2 correlations were  $\pm 40^\circ\text{C}$  the upper layer temperature at the end of the experiments. However, they do not produce temperature versus time profiles.

### **Fleischmann & Parkes**

Fleischmann & Parkes (1997) studied a series of pool fires, which were conducted in a test room 1.0 m x 1.5 m x 1.0 m high with different ventilation openings. The maximum opening was a 0.5 m square window centred in the 1.0 m x 1.0 m wall. The instrumentation used and the configuration of the test compartment is shown below (Figure 4-4). The experiments were conducted outside where ambient conditions were monitored by a weather station.

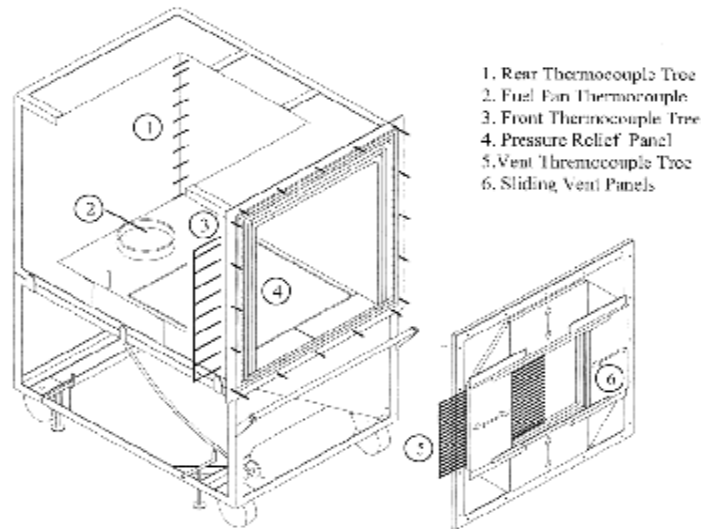

Figure 4-4: Test Configuration. Extracted from Fleischmann & Parkes (1997)

For each experiment there was a three-minute baseline taken to record ambient conditions before ignition of the fuel. The pool fire used heptane with a diameter of 0.2 m and a constant height of 35 mm was used and left to burn for 90 minutes.

A free burn test was conducted and then 14 compartment tests. Nine different vent geometries were used with opening factors ranging from 0.0039 – 0.071 m<sup>5/2</sup>, where:

$$\text{opening factor} = A_{\text{vent}} \sqrt{H_{\text{vent}}}$$

Equation 3

There are a number of methods available to calculate the ventilation rates. In this case they were calculated using the data from the two thermocouple trees because of the small size of the vent and the test compartment other methods were inappropriate. The mass loss rates of all experiments were compared with their corresponding ventilation rates. The free burn test found the steady state mass loss rate to be 0.0011 kg/s, 1.8 times greater than the predicted mass loss rate was calculated to be 0.00063 kg/s.

Parkes (1996) describes the experiments and the results in more detail and compared the experimental results with CFAST models. The experiments were conducted to investigate under-ventilated compartment fires. It was observed that the growth rate in each of the experiments was found to be similar until all the oxygen had been consumed. When flashover occurred, flaming moved from the back of the compartment to the front, extending out of the window. In some of the experiments the vent size

was decreased during the experiment, in these cases if the fire had reached steady state it would only self extinguish if the vent was completely closed.

The summary table below Table 4-2 shows the effect the size of the ventilation opening can have on the mass loss rate.

Table 4-2: Summary of Results. Adapted from Fleischmann & Parkes (1997)

Run #	Width <sub>opening</sub> [m]	Height <sub>opening</sub> [m]	Sill height [m]	Ventilation factor	m <sub>burned</sub> [kg/s]
Free <sub>predicted</sub>	N/A	N/A	N/A	N/A	0.00063
Free	N/A	N/A	N/A	N/A	0.0011
1	0.20	0.50	0.75	0.071	0.0043
2	0.13	0.50	0.75	0.046	0.0023
3	0.13	0.50	0.75	0.046	0.0023
4	0.13	0.38	0.63	0.030	0.0021
5	0.06	0.50	0.75	0.021	0.0017
6	0.13	0.25	0.50	0.016	0.0012
7	0.13	0.25	0.75	0.016	0.0012
8	0.06	0.38	0.63	0.014	0.0011
9	0.03	0.50	0.75	0.011	0.0012
10	0.03	0.50	0.75	0.011	0.0011
11	0.06	0.25	0.50	0.008	0.0007
12	0.03	0.38	0.63	0.007	0.0009
13	0.03	0.25	0.50	0.004	Self extinguished
14	0.03	0.25	0.50	0.004	Self extinguished

These experiments found that for a small pool fire when there was sufficient ventilation the radiation feed back increased the mass loss rate by nearly 7 times the predicted free burn rate.

An article by Parkes & Fleischmann (2005) investigated the effect of the fuel location on the HRR in a compartment fire. A half scale compartment was used for the experiments, which had 0.2 m x 0.2 m heptane pool fires. Three different ventilation conditions were investigated; full open wall, soffit and an open door. The fuel was also located in three different locations; the front, centre and rear of the compartment. Figure 4-5 below shows the configuration of the compartment and the possible locations of the fuel.

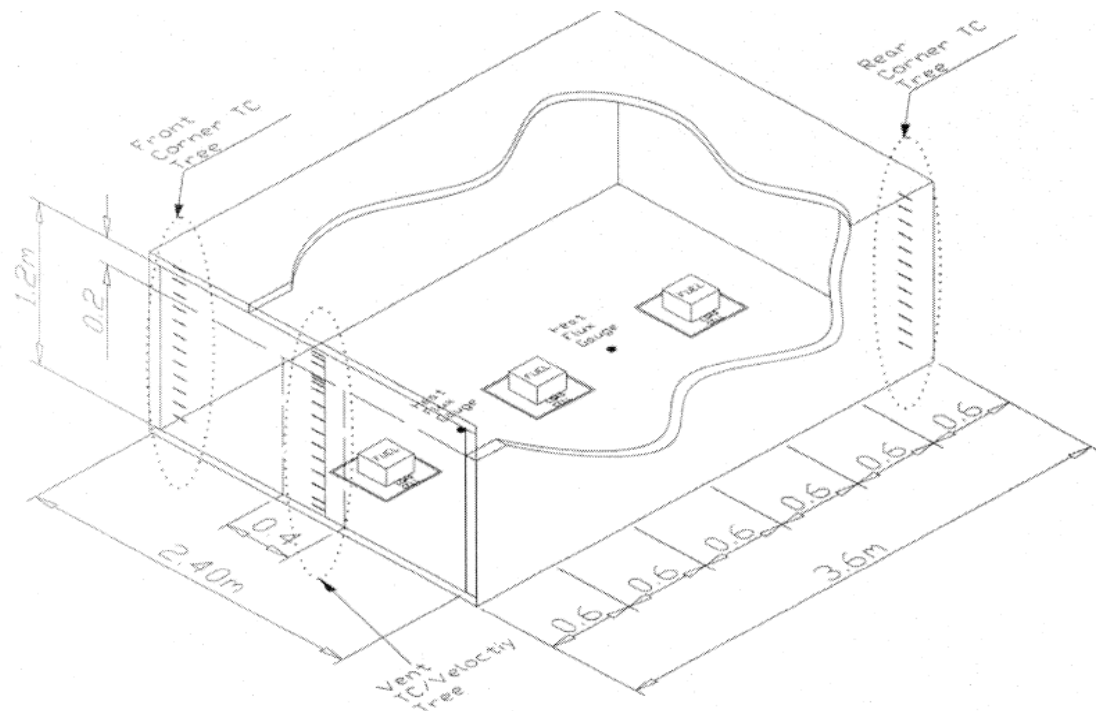

Figure 4-5: Compartment Configuration Parkes & Fleischmann (2005)

Instrumentation in the compartment included; thermocouple trees in the front and rear corners of the compartment. Vertically down the centre of the vent thermocouples and bi-directional probes (pressure transducers) to measure velocity, and heat flux gauges on the floors and walls. Mass loss rate from the pans was also recorded; the fuel was kept at a constant height, and the HRR was recorded.

Nine compartment tests were conducted and one free burn test. The free burn test reached a steady state HRR 3 minute after ignition of around 86 kW. This was lower than expected by the author, it was thought that the increased insulation around the pan and the lack of radiation feedback from the pan sides, due to constant fuel height, accounted from this discrepancy.

Comparing the free burn results with the compartment with the door sized vent. The rear and centre pans took longer to reach a steady state HRR; however the HRR was significantly higher (Table 4-3).

Table 4-3: Selected Results from the Compartment Tests with a Door Sized Vent, Extracted from Parkes & Fleischmann (2005)

Pan Location	Time to peak HRR	Peak HRR	
Centre pan	1800 s	208 kW	139% increase from free burn
Rear pan	2700 s	270 kW	210% increase from free burn

For the experiment with the pan located at the front of the room the HRR decreased to 55 kW. Experimental observations showed that the flames were forced over by the incoming air. The tilt of the

flames could be sufficient enough to decrease the amount of radiation feed back from the flames on to the fuel surface.

The location of the fuel at the rear of the compartment clearly illustrates the difference the ventilation can have on the resulting fire. In the cases with the full wall opening and the soffit vent the HRR was similar to the free burn experiment (70 kW – 100 kW) showing minor radiation enhancement. But when the ventilation was reduced to the open door size the HRR increased significantly to 270 kW.

Thermocouple trees within the compartment showed how the difference in ventilation and location of fuel source could change the compartment environment, changes from a 2-layer to single layer environment are shown below (Table 4-4).

Table 4-4: Summary of experimental results showing layer behaviour.  
Extracted from Parkes & Fleischmann (2005)

Ventilation	Fuel Location	Number of Layers
Full vent	rear	2
Soffit	rear	2
Door	front	transition
Door	centre	transition
Door	rear	1

The difference in the location of the fire could cause a room to flashover. The size and shape of ventilation openings can affect the flame shape and therefore the radiation from the flames on to the fuel surface thereby reducing or increasing the HRR.

### **Peatross & Beyler (1997)**

Peatross & Beyler (1997) conducted compartment experiments and compared the vertical temperatures and the oxygen concentration profiles. The test room had the dimensions 3.3 m x 3.4 m x 3.05 m high and bounded in steel. The fuel was suspended from the centre of the room in a 2 m x 2 m cradle connected to a load cell.

Different combinations of fuel and ventilation condition were tested. These tests were divided into two series, natural ventilation and forced ventilation, each containing 12 tests.

There were a number of variables in these experiments, 4 different fuels were used; 2 pan sizes containing diesel fuel (0.84 m, 0.62 m), wood cribs (1.9 m x 1.9 m x 0.71 m) and polyurethane slabs (2.0 m x 2.0 m x 0.15 m). There were three different ventilation conditions for natural ventilation setups;

an open door, 0.9 m x 2.0 m; a partially open door, 0.225 m x 2.0 m; and an open window, 0.9 m x 0.8 m the sill height 1.2 m above the floor. Ventilation rates were calculated using data from the bi-directional probes. An upper layer temperature was calculated to give an indication of the burn rate enhancement due to radiation feedback.

The forced ventilation experiments have not been discussed in this literature review as they are not relevant to this study.

Natural Ventilation: The ventilation rate calculated from the probe data was consistently less than the theoretical ventilation rate calculated by  $A\sqrt{h}$ . This result was expected as the theoretical rate assumes the flow is choked, maximum amount of air possible given the size of the vent, which is unlikely in reality.

For all fuels the burning rate was highest for the largest vent, due to the highest ventilation rate. The burning rate was higher for the partially open door compared to the window even though they had the area. For all fuels 2-layer burning occurred. The profile in the smaller vents showed there was less mixing so oxygen concentration in the flame base was reduced resulting in a lower burning rate. The only exception in these trends was the smallest fuel source the 62 cm pan. The temperature and oxygen profiles showed no 2-layer characteristics within the compartment which may account for the other different burning characteristics.

Oxygen concentration: Peatross & Beyler (1997) reviewed other studies on the effect of oxygen concentration of the burning rate of fuels. It concludes that furniture calorimeter data used in fire models may seriously over estimate compartment temperatures and flashover potential. The furniture calorimeter tests do not consider the reduced oxygen concentration at the flame base due to under ventilation in compartment fires, causing a decreased burning rate, as little as 1/3<sup>rd</sup> of the free burn rate. This finding suggests a less conservative burning rate can be used in fire predications.

**Andrew et al. (1999)**

Andrews et al. (1999) tested pool fires within a reduced scale compartment (1.4 m x 0.96 m x 1.5 m) with low ventilation conditions. This follows similar research done by Fleischmann & Parkes (2005) with higher ventilation and Peatross & Beyler (1997) who looked at higher ventilation cases and forced ventilation. In this case the ventilation represented the leakage when all doors and windows were closed. The ventilation rate was measured as an inlet air area coefficient  $K_{in}$  where:

$$K_{in} = \frac{\text{leakage\_open\_area}}{\text{cross sectional\_area\_of\_an\_equivalent\_volume\_cubic\_room}} \quad \text{Equation 4}$$

Three cases were chosen 0.0%, 0.11% and 1.0%. In a normal room with a single door a typical  $K_{in}$  range would be 0.09% to 0.6%. The leakage was simulated by inlet air vents on the floor of the test compartment with an outlet in the ceiling. The roof of the enclosure was constructed with steel and no insulation. The fuel for the pool fire was a 200 mm square pan of kerosene. The highest HRR was 70 kW and occurred with the highest ventilation rate. The lower ventilation rate created a steady state HRR of 15 kW from 100 s – 900 s. No ventilation caused the flames to extinguish after about 250 s; approximately 20% of the fuel had been consumed.

The free burn situation with the kerosene fire (diameter of 0.2 m) resulted in a HRR of 0.86 MW/m<sup>2</sup>, in comparison the maximum HRR in the 1.0% ventilation case was 1.75 MW/m<sup>2</sup>. The increase in HRR was due to the radiation feedback from the walls of the compartment. For both ventilation cases the fire was clearly ventilation controlled.

Andrews et al. (1999) cited Heselden et al. (1970) giving a criterion for ventilation control that involved a fire load with an inlet air of greater than 150 kg/m<sup>2</sup> of inlet air.

The HRR was based on the mass loss rate of the fuels. This was then corrected for combustion efficiency, the effect of which was the most obvious in the highest ventilation case. The calculated peak HRR was reduced from 80 kW to 70 kW. For all ventilation cases 0.0%, 0.11% and 1.0% the HRR and the gas compositions were similar in the first stage of the fire, the first 100 s to 200 s. Indicating that within this first stage the fuel combustion was dependant on the air already within the compartment. At this stage the oxygen concentration was 15.5% and the CO 0.1%, the case with no ventilation then quickly extinguished due to lack of oxygen. In the other 2 cases the oxygen concentration continued to drop at the ceiling, but the entrained inlet air was sustaining the flames. The lower ventilation rate was enough to achieve steady state between the HRR and the inlet air. The higher ventilation rate increased the amount of oxygen available, rapidly increasing the HRR. At the peak, the CO and UHC (Unburned Hydrocarbons) concentrations increased, oxygen levels dropped and the fire became oxygen starved.

Temperature was measured 70 mm below the ceiling for the three experiments, the maximum temperatures reached were 180°C, 280°C and 500°C; no ventilation, 0.11% and 1.0%, respectively. The results from the highest ventilation case, 1.0%, can be compared with cases with relatively similar conditions from Peatross & Beyler (1997). In which the low ventilation case ( $K_{in} = 1.7\%$ ) had diesel fuel (0.62 m and 0.84 m diameter pans) and the pool area to floor ratio was similar, 2.7% and 4.9% compared to 3.0% in this case. The maximum temperatures reached in Peatross & Beyler (1997) experiments were 200°C and 300°C significantly lower than the 500°C reached in Andrews et al.



(1999). This difference can be accounted for by the difference in fuel; diesel produces more soot than kerosene so can absorb more heat.

### Thomas & Bennetts (1999)

Thomas, I. R. & Bennetts (1999) stated that it is usually assumed that the burning rates of enclosure fires are proportional to the ventilation factor  $A\sqrt{h}$ . This paper looked at a series of experiments which investigated the effect of different shaped vents on the mass loss rate and the HRR of fuel, in particular the effect of the width of the vents relative to the width of the enclosures. The test compartment had dimensions 1.5 m x 0.6 m x 0.3 m high, two of the walls were made of glass for observation purposes. The fuel was 10 trays (250 mm square, 25 mm deep) of 96% / 4%, ethanol / methanol. A thermocouple was placed 25 mm from the ceiling at the centre of each tray. The tray furthest from the vent was ignited.

Observations from the experiments found that the burning behaviour in the long and wide compartments were similar when the width of the vent was the same as the wall of the enclosure, results Table 4-5.

Table 4-5: Summary of Results from Tests where Vent Width = Compartment Width. Extracted from Thomas and Bennetts (1999)

Enclosure Width x Depth (m)	Vent Width x Height (m)	Mass Loss Rate (g/s)	Duration of Burning (s)	Maximum Temperature (°C)
1.5 x 0.6	1.5 x 0.275	-11.2	475	909
0.6 x 1.5	0.6 x 0.3	-2.7 *	1596 *	823 - 776

\* averaged over 4 repeat tests

In general the following burning behaviour occurred;

- The flames flashed through the compartment before established flaming occurred in the front of the front trays.
- The flame front extended across the whole width of the compartment on the front edge of each tray.
- The flame front continued to move back as the fuel was exhausted.
- Once fuel was exhausted in the front trays the flame front moved to the tray directly behind it, this process continued until all the fuel was consumed.
- The flame front widened at the back trays due to radiation feedback from the back wall.

The mass loss rate was essentially constant for the duration of the experiments in the other tests, though the rates were different for the different compartments. Below is a summary of the other results (Table 4-6). There were four phases of burning observed during the experiments which have been described below.

Table 4-6: Summary of Results from Remaining Tests. Extracted from Thomas and Bennetts (1999)

Enclosure W x D (m)	Vent W x H (m)	Mass Loss Rate (g/s)			Duration of Burning (s)	Maximum Temperature (°C)
		Phase I	II	III & IV		
1.5 x 0.6	0.6 x 0.275	-7.8	-5.2		707	939
1.5 x 0.6	0.3 x 0.275	-3.5	-5.0	-2.6	1169	808
0.6 x 1.5	0.3 x 0.275	-3.4	-2.1	-1.6	2204	834
1.5 x 0.6	0.2 x 0.275	-2.9	-3.8	-2.0	1605	778
0.6 x 1.5	0.2 x 0.275	-2.9	-1.8	-1.1	2686	742

\* averaged over 2 repeat tests

In the long enclosures where the vent width was narrower than the width of the enclosures there were four burning phases observed. In phase I the flame front appears to be confined to the areas directly exposed to the vent. As the flame front moved towards the rear of the enclosure the front extended to the side of the enclosure. At this stage the majority of the hot gases rose to the ceiling and moved toward the vent, a small quantity moved to the back of the enclosure. The flow of gases hitting the front wall surrounding the vent created a back flow and strong circulation of hot gases within the environment. The air coming out of the enclosure was rich in unburned fuel with large flames extending out of the vent. There was a high mass loss rate but relatively low temperatures within the enclosure in phase I and phase II compared to phase III and phase IV. In phase I the flow was visibly 3D (three dimensional).

The phase II was a transition into more of a 2D (two dimensional) flow. Phase III and phase IV showed the flame front moving back as the fuel was exhausted and the flame front widening at the rear of the enclosure due to radiation feedback from the back wall influencing the burning behaviour.

The wide enclosures where the vent width was smaller than the width of the wall showed 3D behaviour though all phases of the experiment, there were three clear stages in burning behaviour. Phase I showed the flame front extended across the front trays across the width of the vent. The flames spread laterally across the trays and the flames extended upwards and across the ceiling mostly towards the vent. The flow of hot gas was deflected by the front wall back into the enclosure where it looped back, lower in the enclosure colliding in the middle and flowing out through the vent underneath the hotter gas layer. There was little recirculation. At this stage the hot gases occupied around 2/3<sup>rd</sup>s of the vent depth. In the second stage the flame front moved back as the fuel was exhausted, the same general flows were observed, however there was an area clear of flames due to the path of the inlet air towards the rear of the enclosure.

Once the fuel in the trays in front of the vents were consumed the flames spread to the sides of the enclosures the flow of hot gases and air similarly looped around and exited through the vent occupying 2/3<sup>rd</sup>s of vent depth. In the wide enclosure tests it was noticed that in some cases flame spread to some trays was not apparent however the fuel was exhausted at the end of the experiments. This was due to large quantities of fuel being evaporated and transported towards the vent.

The mass loss rates for a particular vent size were considerably higher in the wide compartments compared to the long compartments. The temperatures in the compartments were higher above the trays closest to the vents and these temperatures were sustained for longer periods of time. The temperatures were highest in the later stages of the test even though the mass loss rates were lower at these times. This was due to more burning occurring and more heat released within the compartment away from the vent. In the earlier stages of the fire there was substantial flaming outside of the compartment.

#### **Thomas & Smith et al. (2000)**

Thomas, P. H. & Smith (2000) comment on fully developed fires in large compartments, they note that fire behaviour is dependant on location of the ventilation, the long or short wall and relative to the location of the fire, and time equivalence does not account for it.

#### **Girgis (2000)**

Girgis (2000) conducted an experimental study on the behaviour of upholstered furniture in an ISO room 3.6 m x 2.4 m x 2.4 m high with a 0.8 m x 2.0 m opening. These results were compared to results from furniture calorimeter tests. In each environment six upholstered armchairs were tested, the chairs were made specifically for the experiments. They were the same size, design and had the same cover fabric (Figure 4-6). Six different foams were used of which two contained fire retardant.

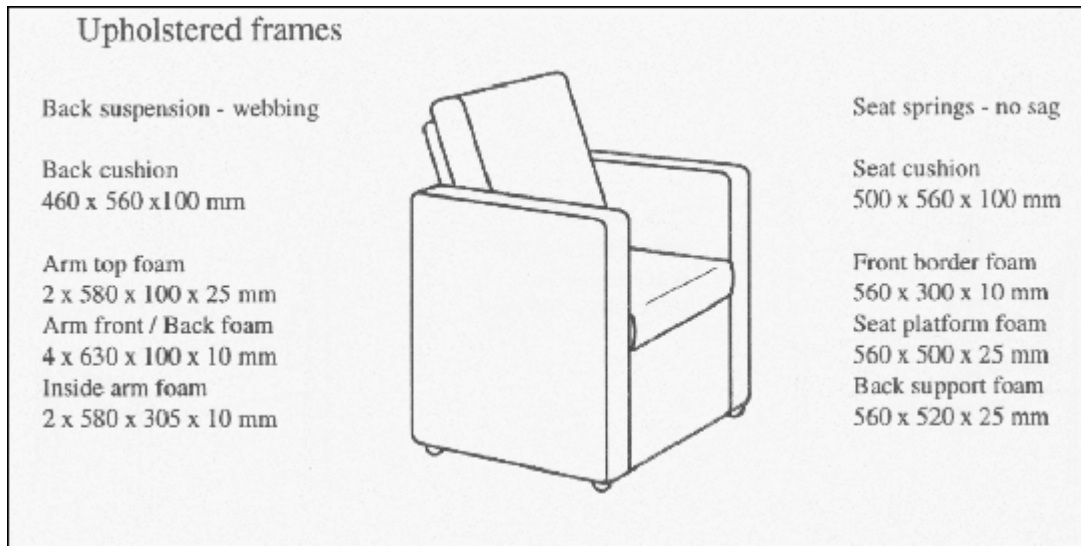

Figure 4-6: Test Chair, Extracted from Girgis (2000)

In the compartment series, the chair was placed in the far right hand corner of the room, a “room corner test” following the ISO9705:1993 procedure. The ignition source for both the compartment tests and the furniture calorimeter tests was a square burner fuelled by LPG situated just above the seat. The burning behaviours between the two environments were compared by evaluating the HRR (peak HRR, time to peak HRR and to a HRR of 500 kW) and the smoke species (specifically ratio of CO/CO<sub>2</sub>) in each experiment, see Table 4-7.

Table 4-7: Summary of Results from the Comparison of Compartment and Free Burn Experiments.  
Extracted from Girgis (2000)

	Free Burn Experiments				ISO Room Experiments			
	Peak HRR [kW]	Time to Peak [s]	Time to 500 kW [s]	Max CO/ CO <sub>2</sub>	Peak HRR [kW]	Time to Peak [s]	Time to 500 kW [s]	Max CO/ CO <sub>2</sub>
Domestic foam	690	150	131	0.002	1450	184	130	0.096
FR Domestic foam	841	149	119	0.011	1340	196	159	0.114
Auditorium foam 1	952	173	102	0.006	1560	144	105	0.087
Auditorium foam 2	1045	121	200	0.006	1590	136	163	0.098
Aviation foam	593	215	106	0.006	1820	210	103	0.109

As expected the peak HRR achieved within the ISO room were higher than those produced by the corresponding chairs in the furniture calorimeter due to radiation feedback from the ceiling and the walls. It was observed that the samples, which produced higher HRR in the furniture calorimeter, also produced high HRR in the ISO room compared to the other samples. However, it was also observed that some of the foams were more adversely affected in the compartment environment than others. The

rank from best to worst in term of fire performance was not the same for the ISO room tests and the furniture calorimeter tests. This can also be seen in the slight variations in the time to reach 500 kW. There are also degrees of variability due to factors like local heating/ flaming, varying ambient conditions, local variations in fabric and foam. Testing involving repeats would be necessary for a statistical analysis of the burning behaviour of the chairs.

The ratio of CO/CO<sub>2</sub> increases significantly (10 – 48 times) when the chairs were in the ISO room. This was due to incomplete combustion caused by ventilation limits in the room. This illustrated the possibility of increased toxicity of upholstered items in a compartment, increasing the risk of life safety to occupants.

### **Delichatsios & Silcock (2003)**

Delichatsios & Silcock (2003) focus on the steady state phase of a compartment fire, Delichatsios & Silcock (2003) recognise the nature of the growth period in a fire can vary and is the most difficult phase to predict. The growth phase is dependant on a number of different variables including the fuel type, its configuration and distribution within the enclosure and the intensity of the ignition source. This work does not consider the growth phase or the transition from the growth phase to the steady state phase. However it does recognise there are a number of different transitions.

The article identified two variables that the burning rate depended on:

- Heat flux on the fuel surface received from the flames and hot gases
- Pyrolysis and combustion properties of the material being burnt

By performing a global energy balance in the enclosure the flow and the pyrolysis rate can be pictured semi quantitatively. By assuming ventilation controlled conditions it can be assumed all incoming air is consumed. The inlet airflow/ ventilation conditions are dependant on the temperature distribution (layered or uniform). The heat flux depended on the temperature and the smoke concentration. There were generally two temperature regions; higher temperatures near the combustion zone and lower temperatures further away.

It was found the radiative heat flux could be conservatively estimated using the higher temperature and optically thick conditions. Some fuels had no excess pyrolysis so there was no flaming outside the compartment. It was also found that when the pyrolysis rate was at its maximum the inlet air was dependant on the heat flux and the effective pyrolysis area. It was also noted that flames could extend outside the compartment even when the fire was fuel controlled.

## **4.2 Literature Summary of Compartment Effects**

Following is a summary of the results and observations presented in the reviewed literature for investigations of compartment effects:

- Compartment flashover is commonly identified using three variables:
  - Compartment temperatures reaching 500°C – 600°C
  - Radiation on the compartment floor reaching 15 – 20 kW/m<sup>2</sup>
  - Flames extending out of the compartment
- Parameters which increase the severity of a compartment fire are (Harmathy (1979):
  - The heat flux absorbed by the compartment boundaries.
  - Duration of the fully developed fire.
  - Average temperature of the gas within the compartment.
- Small fires in well ventilated compartments were not noticeably affected by compartment effects. Harmathy (1979)
- Gas flow through compartment vents are characterised by fresh air flow into the compartment near the bottom of the vent, hot gas flow out around the top and edges of the vent and a stagnant area in the centre. Babrauskas, V. J. (1984)
- Upholstered furniture fires, which are fuel controlled, do not conclusively show burning characteristics with compartment effects. Babrauskas, V. J. (1984)
- In compartment fires, which reach flashover, the initial growth stage of the fire was similar to a free burn fire. The fires then deviated from the free burn behaviour with a rapid increase in growth rate and higher peak HRR (approximately 50% increase). Blomqvist & Andersson (1985)
- The location of the fire within a compartment and the ventilation affected how the incoming fresh air was entrained into the fires. Dembsey et al. (1995)
- Under-ventilated compartment fires have burning characteristics which are comparable with free burn fires until the oxygen within the compartment was consumed. Parkes (1996), Andrews et al. (1999)
- In reduced scale compartment experiments it was found when there was sufficient ventilation to prevent a fire self extinguishing, radiation feedback effects could increase the mass loss rate by up to seven (7) times. Parkes (1996)
- Burning rate was affected by the configuration of the vents in a compartment fire. Tall thin vents with the same area as wide squat vents have a higher burning rate. Peatross & Beyler (1997)
- In under ventilated compartment fires the oxygen concentration at the flame base can be reduced significantly causing a decreased burning rate, as little as 1/3<sup>rd</sup> of the free burn rate. Peatross & Beyler (1997)

- For the same sized vents the mass loss rates were considerably higher in the wide compartments compared to the long compartments. Thomas, I. R. & Bennetts (1999)
- Temperatures in a compartment fire are hottest close to the vent. Thomas, I. R. & Bennetts (1999)
- Upholstered arm chairs, made from different types of foam, tested in free burn and in compartment fires can have a different rank in fire severity. Girgis (2000)
- The ratio of CO/CO<sub>2</sub> increases significantly in a compartment fire compared to a free burn fire Girgis (2000)
- The steady state burning rate in a compartment fire depends on two variables Delichatsios & Silcock (2003):
  - Heat flux on the fuel surface received from the flames and hot gases.
  - Pyrolysis and combustion properties of the material being burnt
- It was also noted that flames could extend outside the compartment even when the fire was fuel controlled. Delichatsios & Silcock (2003)
- When there was a pool fire in a compartment the locations of the pans resulted in differing times to reach a steady state HRR. In a compartment with a door sized vent pool fires at the rear or in the middle of the compartment took longer to reach a steady state HRR than the free burn equivalent. Fleischmann & Parkes (2005)
- The HRR was significantly higher in a compartment where the pool fires were in the middle of the compartment or the rear of the compartment than in a free burn fire. Fleischmann & Parkes (2005)
- Different ventilation conditions and fuel locations could change the compartment environment from 2-layer to single layer environments. Fleischmann & Parkes (2005)
  - Changing the fuel location could cause the compartment fire to flashover
  - The ventilation shape and size altered the flame shape, changing the amount of radiation feedback on to the fire.

## **5 Literature Review Summary**

### ***5.1 Bedding Assembly Fire Characteristics***

Experimental results from investigations into the burning behaviour of mattresses and bedding were shown to be influenced by:

*Type of mattress* – For example, solid foam mattresses burned more readily and with faster flame spread than innerspring mattresses. They also showed higher occurrences of burnout compared with innerspring mattresses, which smouldered, and self extinguished. Solid foam mattresses were more sensitive to the surrounding environment with greater radiation enhancement compared to innerspring mattresses.

*Inclusion of Bedding* – Inclusion of bedding in a mattress test provides more realistic design fire data. Pillows can significantly affect the burning behaviour of a bedding assembly. Tightly made beds had slower flame spread than loosely or unmade beds. Good fire performance could still be achieved if one component was fire resistant and others were not. For example, a mattress with a fire barrier and bedding material, which was not fire retardant. Conversely, positive effects of fire retardant components could be neutralised when used in combination of other components. Because of the uncertainty of the effects of different combinations of mattresses and bedding, bedding assemblies can only be classed as fire retardant if all components are fire retardant and have compatible burning behaviour.

*Type of test* – For example, the difference between room burns and free burn tests. It was observed that in the early stages of a fire burning bedding assemblies showed similar burning behaviour in the room burn and free burn tests. However experiments showed increase in HRR and CO concentrations in room tests due to radiation feedback and ventilation limitations.

*Ignition source* – A number of different ignition sources are used in bedding assembly tests, for example, cigarettes, matches, small gas burners and larger sources like wooden cribs and larger gas burners. The larger sources rarely mimic actual fires according to accident statistics.

### ***5.2 Upholstered Furniture Fire Characteristics***

Investigations of the burning behaviour of upholstered furniture showed that experimental results were influenced by:



*Frame materials* – for example, the combustible mass of the frame was shown to be inconsequential to the burning behaviour of an upholstered item in the early stages of a fire, but may become involved in later stages of the fire. However it was observed that:

- If the frame failed it could adversely affect the burning behaviour by suddenly exposing large quantities of combustible material.
- Upholstered furniture with wooden panels within the frame was more resistant to ignition than those without wooden panels. (Lawson, J. R. W. et al. (1984)
- Chairs with no frames causes the most hazardous conditions because of the large amount of combustible material available.

*Internal construction* – For example, cushions supported by webbing showed higher HRR and faster burning rates. This was attributed to the fire burning through the webbing and forming a pool fire and forming a pool fire inside the chair, significantly increasing radiation enhancement.

*Foam, Cover and Interliner Materials* – Materials behave differently in fire for example, cotton fabrics can char, forming a char layer which can slow fire growth and lower the HRR (Krasny & Babrauskas (1984). Whereas, thermoplastic fabrics like nylon tend to melt, forming pool fires and exposing more combustible material (Ohlemiller & Shields (1994). Fire retardant treatments can restrict fire growth and HRRs but can also have adverse affects. For example, fire resistant foams and materials (cotton) can produce a higher CO peak and smoke density, compared to standard polyurethane foams and cotton (Kallonen et al. (1985).

Armchairs and loveseats tend to produce HRR profiles with fast growth rates and one distinct peak. However two distinct peaks are sometimes identified, the first relates to the cover fabric and the second to the foam. Interliners generally slow the growth rate of a fire, especially when fire rated, however it has been observed that interliners can fail without breaking. This occurred when the heat transfer through the interliner was large enough to melt the foam underneath it, in some cases sufficient heat transfer occurred that the foam ignited (Ohlemiller & Shields (1994).

*Other design features* – Many covers contain zippers, preliminary experiments found nylon zippers used on fabric covers can fail before the cover, exposing the foam (Cleary, T. et al. (1992). This has serious implications to using test data for design as furniture test specimens often do not use zippers. Zipper failure could severely compromise the fire resistance of an item and change its burning behaviour. Furniture trimmings can increase the ignitability of upholstered items , due to the increase in smouldering potential (D'Silva & Sorensen (1996b, (1996a).

*Size and geometry of the furniture item* – For example, office chairs generally had lower HRRs compared to easy chairs, easy chairs lower HRRs than loveseats and loveseats lower HRRs compared to 3-seater sofas. The lower HRRs are generally attributed to less combustible material. An example of the influence of geometry is, it was found that arms on upholstered furniture increased the HRR and the fire growth rate; this was attributed to increases in radiation feedback.

*Type of test* – For example, the difference between room burns and free burn tests. It was observed that in the early stages of a fire upholstered furniture has a similar burning behaviour in the room burn and free burn tests. However experiments showed increase in HRR and CO concentrations in room tests due to radiation feedback and ventilation limitations.

*Ignition and fire propagation* – No matter how small the ignition source there is always some statistical probability it will ignite a larger item (e.g. an upholstered chair) leading to a sizeable fire. Upholstered furniture which is smouldering may have a time delay of several hours before flaming combustion initiates spontaneously. (Cleary, T. G. et al. (1994). It was observed that fire spread along the cushion crevices.

### **5.3 Compartment Effect Fire Characteristics**

*Compartment Effects* – In the early stages there are no compartment effects, the growth rate and burning characteristic are similar to a free burn fire, regardless of the compartment size or the ventilation conditions. Fuel controlled upholstered furniture fires did not conclusively show any compartment effects (Babrauskas, V. J. (1984).

The severity of a compartment fire is dependant on the heat flux on to the fuel and the heat flux absorbed by the compartment boundaries, the pyrolysis and combustion properties of the fuel, the duration of the fire and the compartment temperatures.

*Radiation feedback* – Depends on compartment size / height, location of the fire, compartment temperatures, and flame shape. Radiation feedback is the amount of heat flux on to the fuel received from the flame and hot gases from the fire.

Radiation feed back can significantly affect the fire. For example, in an under ventilated compartment it can increase the mass loss rate of the fuel by up to seven times (Parkes (1996). For example, a fire in the back or the middle of a compartment had increased radiation effects and therefore a higher HRR compared to a fire in the front of the compartment (Parkes & Fleischmann (2005).

*Ventilation* – The ventilation in a compartment governs whether the fire is fuel controlled or ventilation controlled. For example, in a well ventilated compartment with a small fire the compartment effect on the fire was negligible (Harmathy (1979)). An under ventilated compartment fire caused the fires to self extinguish. The location and geometry of a vent in a compartment can affect the fire, for example the same sized vent on the long wall has a much higher burning rate than on the short wall (Thomas, I. R. & Bennetts (1999) , a tall narrow vent has a much higher burning rate than a short wide vent of the same area (Peatross & Beyler (1997)). In real fires the whole area of the vent may not be utilised in the flow of gases into and out to of the compartment. (Babrauskas, V. J. (1984)

*Fuel type* – For example, synthetic polymer and cellulosic fuels behave differently in the same ventilation conditions (Harmathy (1979)). For example, upholstery chairs with different types of foam when tested in free burn and in a compartment had a different rank of severity (Girgis (2000)).

*Temperatures* – For example, in a compartment fire the hottest temperatures are near the vents.

*Burning Rate* – Compartments change the burning rate of the fire. For example, in an under ventilated fire the flame base was significantly reduced which decreased the burning rate by as much as a third of the free burn rate (Peatross & Beyler (1997)).

*Fire Location*– The location of a fire relative to the vents and walls and change the degree the compartment affects the fire. For example, the location of a pool fire in a compartment (rear, middle or front of the compartment) changed the time it took for the fire to reach steady state (Parkes & Fleischmann (2005)).

*Flashover* –Whether flashover occurs in a compartment depends on the fuel location and ventilation conditions as well as the fuel load.

## 6 Furniture Data

One of the objectives of this project required the collection of fire test data for furniture items to aid the development of standardised design fires. By looking at all the available data, general fire characteristics of particular furniture items could be identified, as well as extreme fire events. The data plus associated references was compiled into a single database, thereby making the information more accessible for use in all areas of fire engineering, from research to consultancy. Data was collected from articles in the literature review, where available, and relevant experimental data from the University of Canterbury.

### 6.1 Available Databases

There are also a number of databases currently available in electronic form. In some cases access to data is free, where in others, online database access is approved after membership has been purchased or the information is sent in CD form.

The databases were reviewed to determine which references have already been documented, what data was recorded and how much data / documentation was available. This project looked primarily at databases which were freely available. It was noted during the review that many of the items and references were found in more than one database.

#### 6.1.1 HRR Database – University of Canterbury

The HRR database at the University of Canterbury (Spearpoint (2001a)) is a web based database which can be downloaded and viewed on the client application SelectFire, and this was used as a starting point. This database contains experimental data from a variety of objects including but not limited to cars, christmas trees, clothing, upholstered furniture and beds. The items relevant to this project that were available on the database are shown in Table 6-1

Table 6-1: Data Available on HRR Database Spearpoint (2001a)

General Description	Number of Items
Double bed with night stand	2
Bunk bed	1
Easy chairs (Armchairs)	12
Love seats (2-seater sofas)	3
Mattresses	8
Pillows	6
3-seater sofas	2

An example of how the data is displayed online is shown below in Figure 6-1. Each item had the following information, subject to availability:

- A short description of the item
- A more detailed description of the item
- Reference of the source of the data
- Initial mass [kg]
- Heat of Combustion [J/kg]
- HRR data [kW] with respect to time [s]

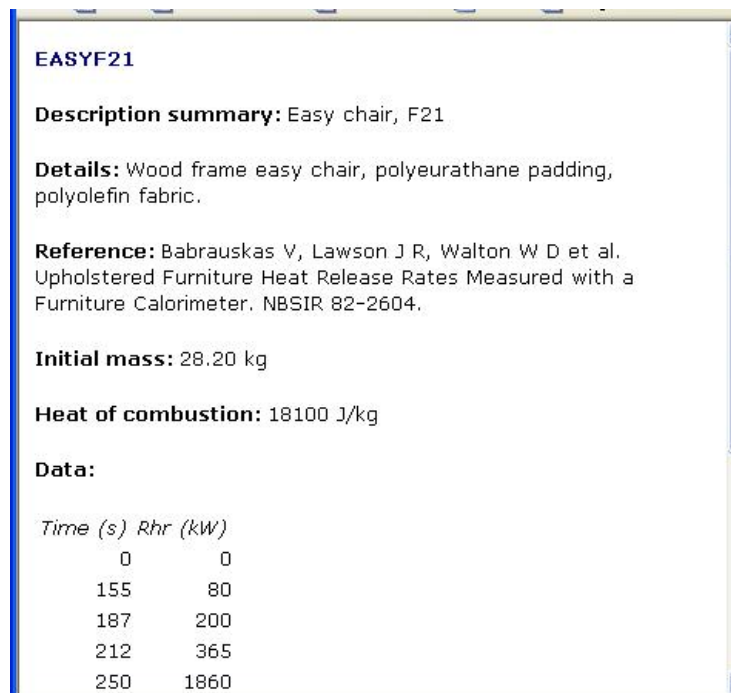

**EASYF21**

**Description summary:** Easy chair, F21

**Details:** Wood frame easy chair, polyurethane padding, polyolefin fabric.

**Reference:** Babrauskas V, Lawson J R, Walton W D et al. Upholstered Furniture Heat Release Rates Measured with a Furniture Calorimeter. NBSIR 82-2604.

**Initial mass:** 28.20 kg

**Heat of combustion:** 18100 J/kg

**Data:**

<i>Time (s)</i>	<i>Rhr (kW)</i>
0	0
155	80
187	200
212	365
250	1860

Figure 6-1: Example of Item in HRR Database Spearpoint (2001a)

### 6.1.2 NIST – Various Databases

One of the earliest collections of test data available was the report “Upholstered Furniture Heat Release Rates Measured with a Furniture Calorimeter” Babrauskas, V. et al. (1982). These items are repeated in many different databases, including all those reviewed in this report, and the results are quoted in a number of papers summarised in Chapter 3 in the literature review. Chairs, 2-seater sofas and 3-seater sofas are among the items included in this report. Total mass, fabric and foam types were published, however specifics on dimensions and material densities were not. Each item was made with simple but realistic designs including wood frames, one type of cushioning material and single cover fabric on each item.

Photographs of each item are given, with test observations and the following data recorded:

- Time to peak
- Peak HRR
- Smoke production
- Target irradiance
- Effective heats of combustion

A small number of reproducibility tests were conducted where an armchair and loveseat were tested twice, in slightly different test conditions. Mass factors, frame factors, style factors, padding factors and fabric factors were also calculated for use in estimating peak HRR from small scale tests.

The report "Fire Performance of Furnishings as Measured in the NBS Furniture Calorimeter. Part 1." Lawson, J. R. et al. (1983) included the easy chairs, loveseats and sofas reported in Babrauskas, V. et al. (1982) but contained more detail about the construction and materials of the chairs. The report gives test observations, with data presented graphically. Other items tested included waiting room and patient style chairs, bedding, stand-alone wardrobes and bookcases, many of the items are referenced to reports and articles summarised in Chapter 3 in the literature review.

The National Institute of Standards and Technology have a database, FASTDATA NIST (1999), which is available online and on CD. The relevant entries in this database are listed below in Table 6-2.

Table 6-2: Data Available on FASTDATA NIST (1999)

General Description	Number of Items
Bed with nightstand	12
Bunk bed	1
Easy chairs (Arm chairs)	1
Love seats (2-seater sofas)	3

Information includes whether the results have been published and if so, the journal or report they appear in. There are a number of time profiles shown including HRR, temperature, combustion products, interface height, depending on the type of test and data collected. The NIST website also has a number of other items and room scenarios not directly relevant to this project including office cubicles, building components, cone calorimeter tests.

### 6.1.3 Initial Fires – Lund University

The report and accompanying database “Initial Fires, HRR, smoke production and CO Generation single items and room fire tests” Särndqvist (1993) collated test data from a number of references including unpublished data and some already mentioned in the literature review in Chapter 3. The database is classified by construction components, upholstered furniture is classified under furniture and fittings, and as such this is the only class discussed in this report. Test items include individual items such as, upholstered furniture mock-ups and groups of items/ room scenarios such as bedrooms, laboratories (irrelevant) and offices (to be used with care in a residential building). Tests include furniture calorimeter tests and a variety of room tests, and testing conditions vary.

For some items there was limited information available as it was dependant on the original source. “Initial Fires, HRR, smoke production and CO Generation single items and room fire tests” included the data published in the database by Lawson, J. R. et al. (1983). All the units within in this database have been standardised. Details in the database include:

- A detailed description of the item, including materials and approximate mass [kg].
- An outline of the test procedure including ignition source and test environment.
- Effective heat of combustion [MJ/kg].
- A list of the results collected in each particular experiment. For example; HRR vs. time, Smoke production vs. time, combustion products like CO and CO<sub>2</sub>.
- Reference.

Time histories of variables were displayed graphically in the hardcopy (.pdf) version of the database, as shown in Figure 6-2. The database was accompanied by a .zip file which contained the data points in .fir files.

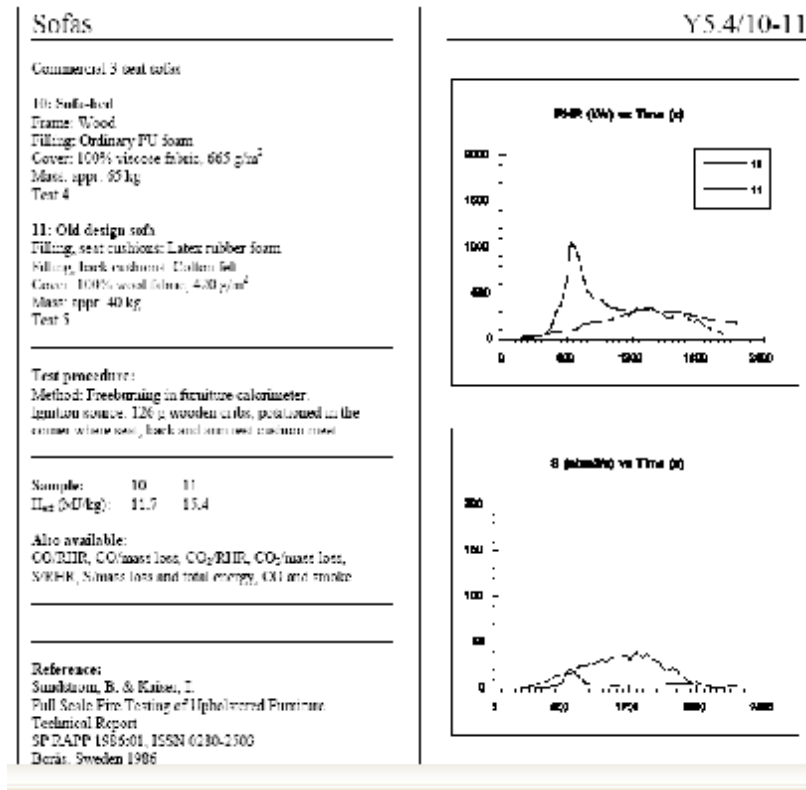

Figure 6-2: Example of Data in Initial Fires Database Särndqvist (1993)

The Initial Fires Särndqvist (1993) database contains all the relevant items found in the database by Lawson, J. R. et al. (1983). Table 6-3 is a lists the relevant items available in The Initial Fires Database Särndqvist (1993).

Table 6-3: Items Available on the Initial Fires Database Särndqvist (1993)

General Description	Number of Items
Easy chairs (Arm chairs)	9
Love seats (2-seater sofas)	2
3-seater sofas	6
Mock-ups (2 cushion)	36
Mock-ups (4 cushion)	9
Mock-up sofas (6 cushion)	5
Beds and bedding	13
Mattresses	2
Pillows	6



## 6.1.4 CBUF Data

The CBUF report (Sundström (1994) that was discussed in Chapter 3 compiled the results of hundreds of experiments conducted on commercially available furniture items and specially made furniture items. These experiments were conducted using furniture calorimeters, ISO 9705 rooms and smaller and larger rooms. The tests conducted by CBUF are especially useful because furniture calorimeter tests and room test results can be compared directly, as the furniture items have the same construction and combustible material. Not all of the data collected in each individual experiment was published in the final report, however some of the results have been entered into a database created by the Swedish National Testing and Research Institute (SP). The SP Fire Database (Ljung (2005) is available free online and the data can be downloaded in .xml format. Figure 6-3 shows an example of the data displayed on the website. Currently there are 61 CBUF items in the SP database which includes armchairs, loveseats and 3-seater sofas.

The screenshot shows the SP Fire Data Base website interface. At the top left is the SP logo (Swedish National Testing and Research Institute). A navigation menu includes: Building, Energy, Metrology, Environment, Engineering, Electronics, and Search. Below the logo are buttons for 'Search by Data', 'Help', 'Print', and 'Details'. The main content area is titled 'SP Fire Data Base' and 'SP Swedish National Testing and Research Institute'. A 'Show Details' section is active, displaying the following information:

**Foot**

Keyword	Value
Method	EN 13708 Furniture: Furniture Polyurethane
Material	Foam chair foam
Product	
Object	3-seater sofa
Series	
Method	EN 13708 Furniture: Furniture (COMIT)
Reference	COMIT - The Safety, SP-Undersökningarna, E2, rapport EUP-10477. For contact SP for more information
Comments	Unpublished: data from the database
Order	
Transfer	1
Import/Date	2008-03-04 14:07

**Scalar**

Scalar	Value
Peak heat release (kW)	200.0
Total heat release (MJ)	200.0
Total mass loss (g)	200.0
Total mass loss (g)	200.0
Average heat of combustion (MJ/kg)	10.000

**Time (s) HRR (kW) SPR (m<sup>2</sup>/s)**

0	0.0000000000000000	0.0000000000000000
1	0.0000000000000000	0.0000000000000000
2	0.0000000000000000	0.0000000000000000

Figure 6-3: Example of Item Data from SP Fire Database

The database contains the furniture calorimeter tests for each type of furniture item tested. Information on the database includes:

- A brief description of fabric and foam material.
- A brief item description (Object and Comment).
- Test conditions (Method).

- References.

The database also has records of the HRR, total heat released, initial mass, total mass loss and the average heat of combustion. Time histories are given for HRR and smoke production rate graphically and as data points. The report then contains detailed descriptions of the construction of each item, the testing procedure and some of the other data collected, for example combustion product peak concentrations and smoke production data.

The databases currently available often contain data from in-house reports where the results have not been otherwise published. One of the difficulties in creating a database of furniture fire tests is that test data is often difficult to access. There have been many furniture tests from which test results may never be disclosed. Testing facilities test a number of items to ensure furniture on the market complies with fire regulations. Unfortunately the results are specific to particular manufacturers and can be commercially sensitive. For this reason the majority of results from testing facilities remain in-house, unpublished and often remain confidential.

## ***6.2 Collating Upholstered Furniture Data***

The upholstered furniture data was extracted from the articles and reports in the literature review. Upholstered furniture data in the databases identified above were also included in the collation of upholstered furniture data. The information was put into a form compatible with HRR database Spearpoint (2001b). When forming the database for this project, all available data from relevant test methods and samples were first transferred into spreadsheet format where it was available. This allowed for ease of comparison of different data sets by converting data into common units. Often the depth of detail varied from one reference to another, which led to difficulties when attempting to compare fire behaviour between different items.

Where data was given in articles and reports in hard copy or digital .pdf form, but where the raw data was not available the data was digitised. The digitising software 'Grab It! XP' Preble (1998 - 2001) was used to convert graphs to data points through an excel interface, as shown in Figure 6-4. Most of the data acquired through this method were HRR vs. time profiles.

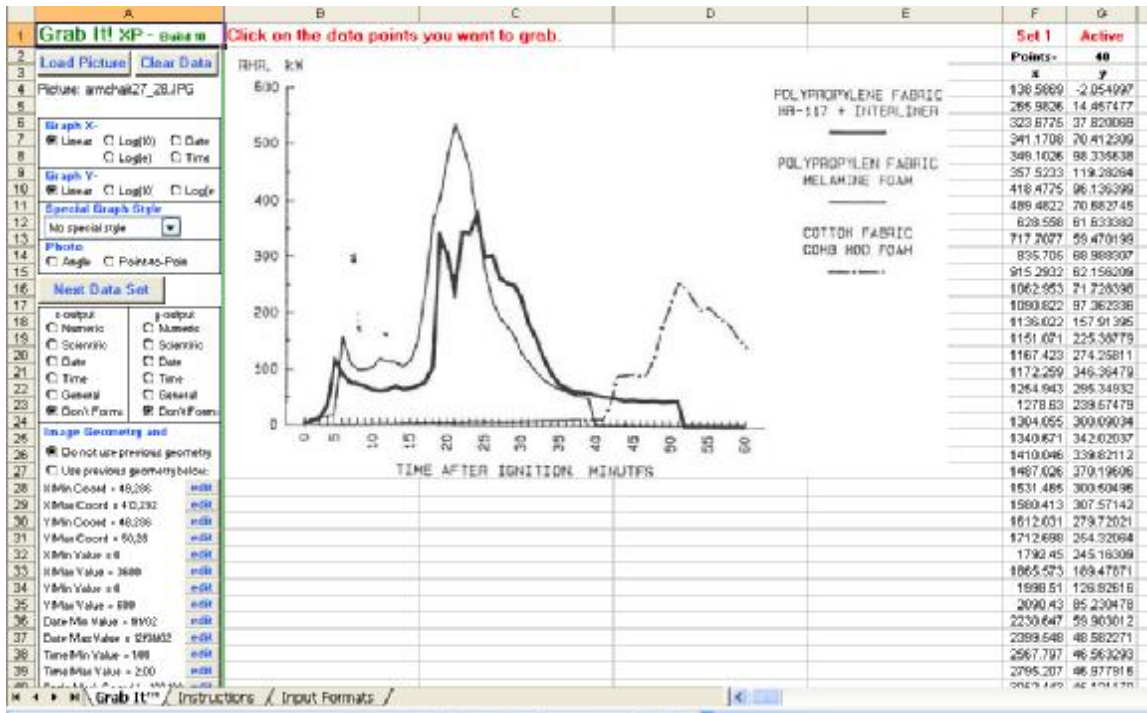

Figure 6-4: A screen shot of data points translated using Grab It! XP

New data was stored in excel, with each worksheet representing one item (Figure 6-5). All available information on each item and the testing details were recorded on the worksheet, including any photos or diagrams of the item and the original graph the data was extracted from.

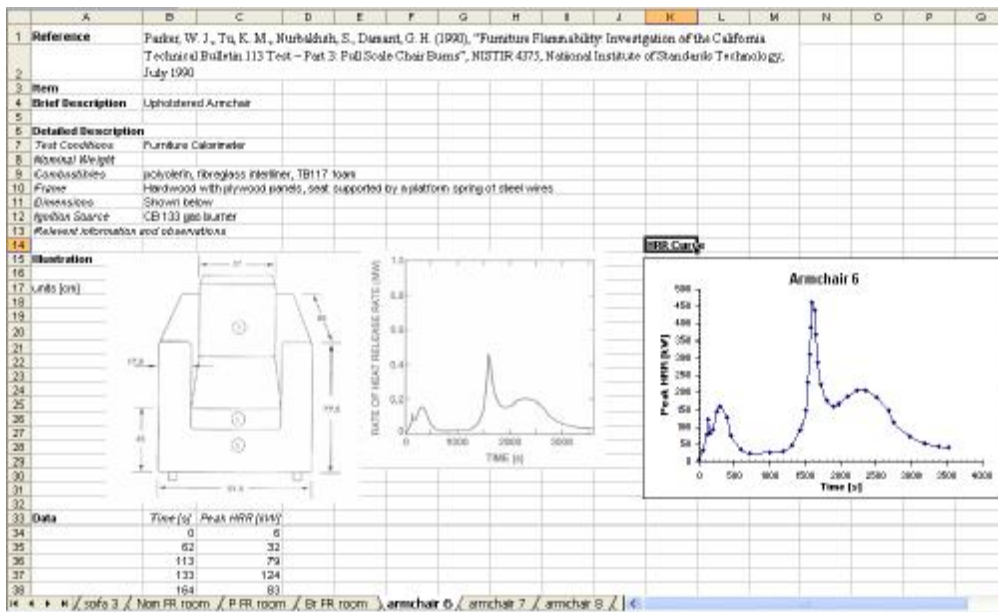

Figure 6-5: Example of Excel Worksheet of Furniture Item

In addition to data found in the literature, raw data was available from theses from the Fire Engineering Department at the University of Canterbury. The theses of Denize (2000; Enright (1999; Firestone (1999; Girgis (2000; Hill (2003) all conducted experiments following the CBUF protocol. Denize (2000) conducted 10 furniture calorimeter experiments using the standard CBUF armchair, using different foam/ fabric combinations. Enright (1999) tested chairs available commercially including; armchairs and 2-seater sofas in the furniture calorimeter. Enright (1999) results were compared with results from the CBUF model. Firestone (1999) used data collected by CSIRO where they used the Nordtest testing procedure, which has slightly different furniture designs and ignition sources (400g crib). Firestone (1999) tested four different foam/ fabric combinations in armchairs, 2-seater sofas and 3-seater sofas. Girgis (2000) tested 6 armchairs which were identical except for the type of foam, in an ISO room. The test results were used to compare burning behaviour with identical chairs tested by Denize (2000). Hill (2003) tested 55 chairs in the furniture calorimeter. The chairs were specially made to CBUF dimensions for frame designs 1 (standard design), 3 (open leg design) and 4 (no arms and open leg design). Arm chairs and 2-seater sofas were tested with varying designs and fabric/ foam combinations.

### **6.3 Access Database**

Data found from the above resources was collected in a Microsoft Access database which could also be viewed in Excel (Appendix A). The data was summarised into table format so that the time histories of any variables was not included. The headings included:

- Description
  - Foam
  - Fabric Type, Fire Resistant (FR): Yes/ No
  - Interliner: Yes/ No
- Test condition: Free burn/ Room Burn
- Ignition Source
- Peak HRR [kW]
- Time to peak HRR [s]
- Total heat released [MJ]
- Effective heat of combustion [MJ/kg]
- Combustible mass and total mass [kg]
- Detailed description
- Data available
- Reference

While there is the possibility of adding headings, they have been restricted to those most commonly found in the references used in this project. Extra information and data available was described in the 'Detailed Description' and 'Data Available'. A section of the database in Excel is shown below in Figure 6-6.

	A	B	C	D	E	F	G	H	I	J	K	L	M	N	O	P	Q
1																	
2	ID	Description	Foam	FR	Fabric	Interliner	Test Condition	Ignition Source	Peak HRR (kW)	Time to Peak HRR (s)	Total Heat Release (MJ)	Heff (MJ/kg)	Combustible Mass (kg)	Total Mass (kg)	Detailed Description	Data Available	Reference
3	1	2 Seater Sofa	Aviation PU foam	FALSE	wool	FALSE	Free Burn	Gas Burner	127	76	16.6	0	3.175		30 kW square gas burner centre of seat. Design S6 - Standard 2 seater. Soft combustibles 3.175 kg. No 2nd peak	HRR Profile, Mass Profile,	Hill, G. R. (2003), Burning Behaviour of Upholstered Furniture, Masters Thesis, University of Canterbury
4	2	2 Seater Sofa	Standard PU foam	FALSE	wool	FALSE	Free Burn	Gas Burner	1785	234	288.9	0	8.52		30 kW square gas burner centre of seat. Design S6 - Standard 2 seater. Soft combustibles 8.520 kg. 1st peak not distinguishable	HRR Profile, Mass Profile,	Hill, G. R. (2003), Burning Behaviour of Upholstered Furniture, Masters Thesis, University of Canterbury
5	3	2 Seater Sofa	Aviation PU foam	FALSE	polypropylene	FALSE	Free Burn	Gas Burner	1607	167	325.7	0	3.294		30 kW square gas burner centre of seat. Design S6 - Standard 2 seater. Soft combustibles 3.294 kg. 1st peak not distinguishable	HRR Profile, Mass Profile,	Hill, G. R. (2003), Burning Behaviour of Upholstered Furniture, Masters Thesis, University of Canterbury
6	4	2 Seater Sofa	Standard PU foam	FALSE	polypropylene	FALSE	Free Burn	Gas Burner	2079	124	323.8	0	8.538		30 kW square gas burner centre of seat. Design S6 - Standard 2 seater. Soft combustibles 8.568 kg. 1st peak not distinguishable	HRR Profile, Mass Profile,	Hill, G. R. (2003), Burning Behaviour of Upholstered Furniture, Masters Thesis, University of Canterbury
7	5	2 Seater Sofa	Aviation PU foam	FALSE	wool	FALSE	Free Burn	Gas Burner	1347	794	207	0	8.59		30 kW square gas burner centre of seat. Design S7 - 2 seater open legs. Soft combustibles 8.590 kg. 1st peak 182 kW (95s)	HRR Profile, Mass Profile,	Hill, G. R. (2003), Burning Behaviour of Upholstered Furniture, Masters Thesis, University of Canterbury
8	6	2 Seater Sofa	Standard PU foam	FALSE	wool	FALSE	Free Burn	Gas Burner	1459	258	211.7	0	7.935		30 kW square gas burner centre of seat. Design S7 - 2 seater open legs. Soft combustibles 7.935 kg. 1st peak 468 kW (150s)	HRR Profile, Mass Profile,	Hill, G. R. (2003), Burning Behaviour of Upholstered Furniture, Masters Thesis, University of Canterbury
9	7	2 Seater Sofa	Aviation PU foam	FALSE	polypropylene	FALSE	Free Burn	Gas Burner	1423	186	232.1	0	7.346		30 kW square gas burner centre of seat. Design S7 - 2 seater open legs. Soft combustibles 7.346 kg. 1st peak not distinguishable	HRR Profile, Mass Profile,	Hill, G. R. (2003), Burning Behaviour of Upholstered Furniture, Masters Thesis, University of Canterbury
10	8	2 Seater Sofa	Standard PU foam	FALSE	polypropylene	FALSE	Free Burn	Gas Burner	1846	149	255.4	0	6.783		30 kW square gas burner centre of seat. Design S7 - 2 seater open legs. Soft combustibles 6.783 kg. 1st peak not distinguishable	HRR Profile, Mass Profile,	Hill, G. R. (2003), Burning Behaviour of Upholstered Furniture, Masters Thesis, University of Canterbury
11	9	2 Seater Sofa	Aviation PU foam	FALSE	wool	FALSE	Free Burn	Gas Burner	1411	797	190	0	7.587		30 kW square gas burner centre of seat. Design S8 - 2 seater straight back open legs. Soft combustibles 7.587kg. No 2nd peak HRR	HRR Profile, Mass Profile,	Hill, G. R. (2003), Burning Behaviour of Upholstered Furniture, Masters Thesis, University of Canterbury
12	10	2 Seater Sofa	Standard PU foam	FALSE	wool	FALSE	Free Burn	Gas Burner	1384	262	194.2	0	7.166		30 kW square gas burner centre of seat. Design S8 - 2 seater straight back open legs. Soft combustibles 7.166kg. 1st peak not distinguishable	HRR Profile, Mass Profile,	Hill, G. R. (2003), Burning Behaviour of Upholstered Furniture, Masters Thesis, University of Canterbury
13	11	2 Seater Sofa	Aviation PU foam	FALSE	polypropylene	FALSE	Free Burn	Gas Burner	1289	218	220.1	0	6.644		30 kW square gas burner centre of seat. Design S8 - 2 seater straight back open legs. Soft combustibles 6.644kg. 1st peak not distinguishable	HRR Profile, Mass Profile,	Hill, G. R. (2003), Burning Behaviour of Upholstered Furniture, Masters Thesis, University of Canterbury
14	12	2 Seater Sofa	Standard PU foam	FALSE	polypropylene	FALSE	Free Burn	Gas Burner	2052	129	219.4	0	6.106		30 kW square gas burner centre of seat. Design S8 - 2 seater straight back open legs. Soft combustibles 6.106kg. 1st peak not distinguishable	HRR Profile, Mass Profile,	Hill, G. R. (2003), Burning Behaviour of Upholstered Furniture, Masters Thesis, University of Canterbury
15	13	2 Seater Sofa	Polyether	FALSE	polyester / cotton	FALSE	Free Burn	Gas Burner	2248	161	476	0	7.65		30 kW square LPG gas burner centre of seat. Photo of chair design available in thesis, commercially purchased chairs. Soft combustibles 7.65 kg	HRR profile, mass loss, CO, CO2, O2 production, flame temperature profiles, heat flux, film of HRR profile,	Enright, P. A. (1999), Heat Release and the Combustion Behaviour of Upholstered Furniture, Doctorate Thesis, University of Canterbury
	14	2 Seater Sofa	Polyether	FALSE	polyester / cotton	FALSE	Free Burn	Gas Burner	1538	240	447	0	7.16		30 kW square LPG gas burner centre of seat. Photo of chair design available in thesis, commercially purchased chairs. Soft combustibles 7.16 kg	HRR profile, mass loss, CO, CO2, O2 production, flame temperature profiles, heat	Enright, P. A. (1999), Heat Release and the Combustion Behaviour of Upholstered Furniture, Doctorate Thesis, University of Canterbury

Figure 6-6: Example of Data from the Upholstered Furniture Access Database

## **6.4 Summary of Upholstered Furniture Data**

To statistically assess the furniture fire characteristic data was collected from articles in the literature review, freely available databases and in-house raw data.

Data from the literature review tended to be incomplete with varying amounts of detail about the test conditions and the item tested. Most of the data collected this way was digitised using the computer software 'Grab It!' from graphical data in the articles.

There are a number of online databases available, which contain furniture fire data, including databases from the University of Canterbury, Lund University, NIST and the CBUF study. The data has considerably better documentation than results from the articles. There was some data replication between databases and data found in the literature but each database contained some in-house data, which has not been published or is not otherwise available in the public domain.

University of Canterbury has conducted a series of experimental studies on upholstered furniture, using both commercially available furniture items and items made using the CBUF protocol with specific foams / fabric combinations. For these experiments the raw data was available and the accompanying theses detailed the experimental setup, test conditions and construction of the furniture item. The experiments from the University of Canterbury gave valuable insight into the behaviour of furniture produced / available in New Zealand compared with Europe and America, where the majority of the other tests were conducted.

In total 262 furniture items were collected from the various sources, often with database documentation detailing results gathered from articles and papers. It is acknowledged that there is a considerable amount of data, which is not available to the public as it is collected by testing labs and is commercially sensitive, or can be purchased. However this study only looked at freely available data for an initial assessment of furniture characteristics. Data collected is tabulated below as either the test type or the furniture item. A summary of what can be found on the database has been compiled in Table 6-4 and the references from which the data sets were compiled from in below.

Table 6-4: Data available in the Access Database

Classification	Number of Items
Free Burn	176
Room Burn	86
Item Description	
Armchair	210
2-seater sofa	23
3-seater sofa	11
Mattress (& base) / Bed & Bedding	18
Total	262

Below in Table 6-5 is a list of the references of the datasets used in the access database compiled for this thesis.

Table 6-5: References for the Data Sets in the Access Database

	Reference
1.	Babrauskas, V. (1983). "Upholstered Furniture Heat Release Rates - Measurements and Estimation." <i>Journal of Fire Sciences</i> 1(1): 9-32
2.	Cleary, T. G., T. J. Ohlemiller, et al. (1994). "The Influence of Ignition Source on the Flaming Fire Hazard of Upholstered Furniture." <i>Fire Safety Journal</i> 23(1): 79-102
3.	Denize, H. R. (2000), <i>The Combustion Behaviour of Upholstered Furniture Materials in New Zealand</i> , Masters Thesis, University of Canterbury
4.	Enright, P. A. (1999), <i>Heat Release and the Combustion Behaviour of Upholstered Furniture</i> , Doctorate Thesis, University of Canterbury
5.	Girgis, N. (2000), <i>Full - Scale Compartment Fire Experiments on Upholstered Furniture</i> , Masters Thesis, University of Canterbury
6.	Hill, G. R. (2003), <i>Burning Behaviour of Upholstered Furniture</i> , Masters Thesis, University of Canterbury
7.	Lawson, J. R. et al. (1983), <i>Fire Performance of Furnishings as Measured in the NBS Furniture Calorimeter. Part 1</i> . NBSIR 83-2787, U.S.A.
8.	Ohlemiller, T. J., and Villa, K. (1990), "Furniture Flammability: An Investigation of California Bulletin 133 Test. Part II: ...", NISTIR 4348, National Institute of Standards Technology, June, 1990
9.	Ohlemiller, T.J. and Gann, R.G. 2002. <i>Estimating Reduced Fire Risk Resulting From an Improved Mattress Flammability Standard</i> , NIST TN 1446. National Institute of Standards and Technology, Githersburg, MD.

	Reference
10.	Parker, W. J., Tu, K. M., Nurbakhsh, S., Damant, G. H. (1990), "Furniture Flammability: Investigation of the California Technical Bulletin 113 Test – Part 3: Full Scale Chair Burns", NISTIR 4375, National Institute of Standards Technology, July 1990
11.	Schuhmann, J. G. and G. E. Hartzell (1989). "Flaming Combustion Characteristics of Upholstered Furniture." Journal of Fire Sciences 7(6): 386-402
12.	Sundstrom B & Kaiser, I. (1986), Full Scale Fire Testing of Upholstered Furniture, Technical Report SP RAPP 1986:01, Sweden. [Sarqvist (1993),Initial Fires]
13.	Sundstrom, B (ed.) (1993) CBU, Fire Safety of Upholstered Furniture - the Final Report, EUR 16477 EN, European Commission Measurements and Testing.

This access database was used in the analysis of the design fire characteristics (Chapter 7) for upholstered furniture and to assess compartment effects on the design fire described in Chapter 4.



## 7 Specifying Upholstered Furniture Fires

This chapter attempts to identify some of the characteristics of upholstered furniture fires and how these characteristics are affected when the fire takes place within a compartment. To identify these characteristics, data collected during the literature and data review was used. There are many different characteristics that could define a design fire. In Chapter 2 and Chapter 3 characteristics of Upholstered furniture fires have been identified. These characteristics have been analysed, where there was sufficient data, to identify trends. Section 7.4 compares corresponding free burn and room burn experiments of identical furniture items, to analyse how compartment effects have affected the characteristics identified in Section 7.3.

It should be noted that no attempt has been made to equate the analysis of the combustion properties of the furniture data collected to statistical distributions of real furniture found in residential properties. The data used for the statistical analyses was from several sources, all publically available. The data from many of the tests used furniture mock ups rather than real furniture purchased from the commercial market.

Using the data, a probability was calculated to determine recommendations for fire characteristics for various furniture items. Normally a reasonable assumption would be the 95<sup>th</sup> percentile point (i.e. a 95% probability the peak HRR, for example, would be equal to or lower than the stated value) when considering statistical parameters for a design fire. However in this chapter both the 95<sup>th</sup> percentile point and the 98<sup>th</sup> percentile point have been calculated. Enright et al. (2001) found in their study that New Zealand furniture resulted in noticeably more severe fires than those tested in Europe in the CBUF study (Sundström (1994)). As the majority of the data used was obtained from European and American sources the 98<sup>th</sup> percentile was also deemed to be appropriate for this study. The higher percentile thereby recognises the increased severity of New Zealand furniture that may not be sufficiently represented by the data set.

The most widely used method of defining a design fire is by specifying the HRR versus time, often with a  $t^2$  growth rate, when a growth rate is required. Some HRR data was recorded in the majority of the furniture experiment data that has been collated for this thesis. The following variables were used to determine general upholstered furniture fire characteristics were growth rate, peak HRR, time to peak HRR, HRR vs. time profiles and where possible CO/CO<sub>2</sub> data.

To quantify compartment effects data sets where furniture items were tested in free burn and room burn environments were compared.

## 7.1 Statistical Analysis of Existing Data

The 95<sup>th</sup> and 98<sup>th</sup> percentiles were calculated in Excel using the data points. The percentile function “returns the  $k^{\text{th}}$  percentile of values in a range. If  $k$  is not a multiple of  $1/(n - 1)$ , PERCENTILE interpolates to determine the value at the  $k^{\text{th}}$  percentile.” Microsoft Excel Help, Microsoft Office (2003).

In addition to the percentiles calculated using the input data, to aid the statistical analysis the Palisade @Risk tool BestFit (version 4) Palisade Decision Tools - @Risk (2004) was used to fit distribution curves to the data. The 95<sup>th</sup> and 98<sup>th</sup> percentiles of the distribution curve were also determined. The appropriateness of the use of the distribution curve has been discussed on a case-by-case (variable-by-variable) basis.

BestFit fit a number of different distribution curves to the input data, to determine the most appropriate distribution curve the Anderson-Darling (A-D) statistical fit was used to rank the distributions and the highest ranked distribution was used. The A-D statistic, which has been defined below in Equation 5, was deemed the most appropriate as it can account for outlying values in the input data.

$$A_n^2 = n \int_{-\infty}^{+\infty} [F_n(x) - \hat{F}(x)]^2 \Psi(x) \hat{f}(x) dx$$

where

$n$  = total number of data points

$$\Psi^2 = \frac{1}{\hat{F}(x)[1 - \hat{F}(x)]}$$

$\hat{f}(x)$  = the hypothesized density function

$\hat{F}(x)$  = the hypothesized cumulative distribution function

$$F_n(x) = \frac{N_x}{n}$$

$N_x$  = the number of  $X_i$ 's less than  $x$ .

Equation 5 (Extracted from Palisade Corporation, 2004)

Due to the varying nature of upholstered furniture and the relatively small sample sizes used in this study the outlying data points are still significant and require consideration when developing reasonable worst case scenarios for design fires. The top ranked distribution was used in the analysis of the upholstered furniture data. The following distributions were used to describe the data of the burning behaviour of the upholstered furniture:

- Cumulative Ascending
- Extreme Value
- Inverse Gaussian
- Logistic
- Log-Logistic
- Lognormal
- Normal
- Pearson Type V
- Weibull

A summary of the distributions as exerts from the @Risk help files are in Appendix B.

## 7.2 Growth Rate

All the data collected was compared to the  $t^2$ - fire growth rates of slow, medium, fast and ultra fast. The growth rates of the furniture items were analysed by graphing the HRR profiles against the  $t^2$  curves.

The growth rates were ascertained by visual inspection, as follows:

- faster than ultra fast growth rate
- ultra fast and fast growth rate
- fast and medium growth rate
- medium and slow growth rate
- slower than slow growth rate

Tests were considered to have no growth rate when the HRR did not exceed 200 kW. The  $t = 0$  point of the HRR profiles has not been shifted in any of the cases, because in most cases the ignition source was a 30 kW burner. A summary of results is shown in Table 7-1.

Table 7-1: Growth Rates of Fires

Growth Rate (a)	Number of tests	Percentage
More than Ultra fast	0	0 %
Ultra-fast – Fast	12	9.7 %
Fast – Medium	36	29.0 %
Medium – Slow	29	23.4 %
Less than Slow	32	25.8 %
<i>No Growth Rate</i>	<i>15</i>	<i>12.1 %</i>
Total	124	100 %

The 30 kW burner provided a much higher heat source than the ignition sources in most real fires. Therefore the burner was expected to overcome the incipient phase, therefore the  $t = 0$  point has not been moved. However it can be seen in test results (Appendix C) that the upholstered furniture items can still have long incipient stages, when a large ignition source is used, before rapid increases in HRR, as seen in Figure 7-1. This results in many of the tests growth rates have growth rates slower than a slow  $t^2$  growth rate, however when the rapid growth occurred it was significantly fast than a slow  $t^2$  growth rate closer to medium – fast growth rate.

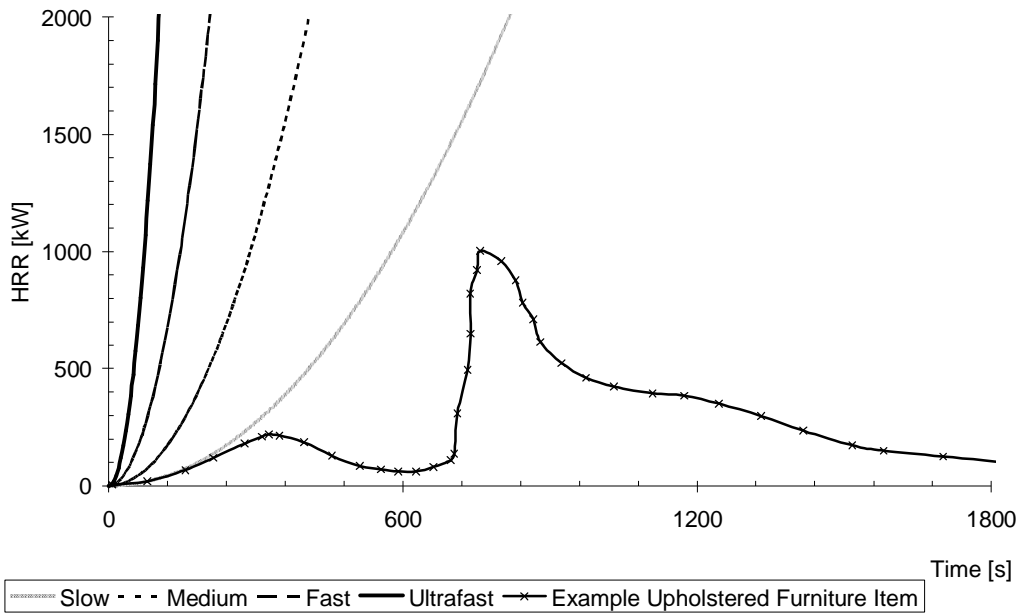

Figure 7-1: Example of Delayed Growth Rate of an Upholstered Furniture Item

The growth rate behaviour and the length of the incipient phase is dependant on a number of factors, some of which are:

- The materials involved in the upholstered item, in particular the foam fabric interactions
- Burner type
- Burner location

These factors are discussed in Chapter 3.2. Because of the natural variability of the burning characteristics it is difficult to predict the incipient phase and whether the  $t = 0$  point should be shifted, making the growth rates hard to quantify.

An evaluation of the growth rates found that there was a fairly even distribution in growth rates between fast and less than slow, with 7.6% of tests giving a growth rate faster than a fast  $t^2$ -fire and 12.7% of tests having no growth rate (i.e. self extinguishing during the incipient stage, less than 200 kW). The distribution of growth rates from the data sets is shown graphically in Figure 7-2.

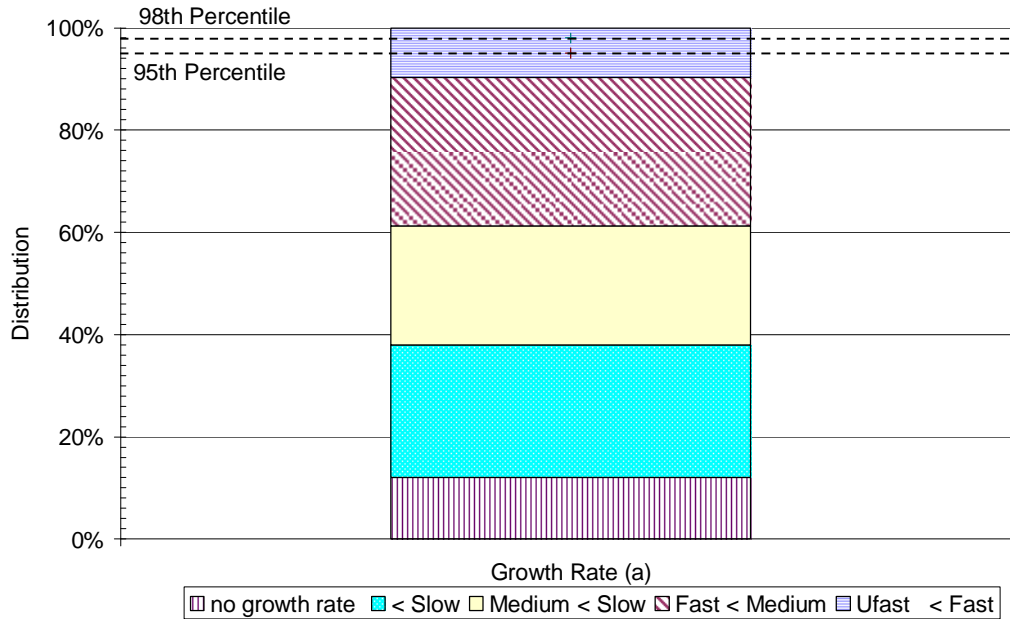

Figure 7-2: Distribution of Growth Rates from Experimental Data

Points representing the 95<sup>th</sup> and 98<sup>th</sup> percentile have been identified from the available data, and Figure 7-2 shows that both percentiles fall within the ultra-fast to fast  $t^2$  growth rate. These results include some room burns, both free burn and compartment fires are in the upper growth rate bracket. Therefore an ultra-fast to fast  $t^2$  growth rate could be considered a free burn and compartment fire growth rate.

The growth rates were ascertained by visual inspection so there is scope for further research to curve fit and mathematically estimate an actual growth rate constant ( $\alpha$ ) for each experiment.

### 7.3 Free Burn Characteristics

The characteristic peak HRRs have been categorised by furniture type; armchairs, 2-seater sofas and 3-seater sofas. Four characteristics were looked at in detail: Peak HRR, time to peak HRR, total heat released and fire growth rates. Below are the results and the corresponding discussion for each of the characteristics.

Bedding assemblies and mattresses have not been analysed or discussed, as the sample sizes were too small. There were 18 data sets for bed and bedding assemblies, nine free-burn tests and nine room burns; however the data was divided into full bedding assemblies, mattresses only, mattresses and bases. These categories are not directly comparable and combining all the categories to define trend would give incorrect results. This is only due to the fact that bedding increases the fuel load; it can also significantly alter the fire behaviour of a mattress, as discussed in Chapter 2. Therefore it was not

appropriate to group mattresses and bedding assemblies together, leaving only four data sets per category.

For each characteristic the values at the 95<sup>th</sup> and 98<sup>th</sup> percentile were determined using the experimental data and the percentiles using the distribution curves. In the Appendix D each characteristic has been graphed; as the experimental data as shown below in Figure 7-3, as a distribution with the appropriate distribution superimposed, and as a cumulative distribution.

### 7.3.1 Peak HRR

Figure 7-3 to Figure 7-5 show the distribution of HRR from the data set of free burn experiments, armchairs, 2-seater sofas and 3-seater sofas, respectively. The y-axis shows the HRR [kW], each bar represents one item of furniture.

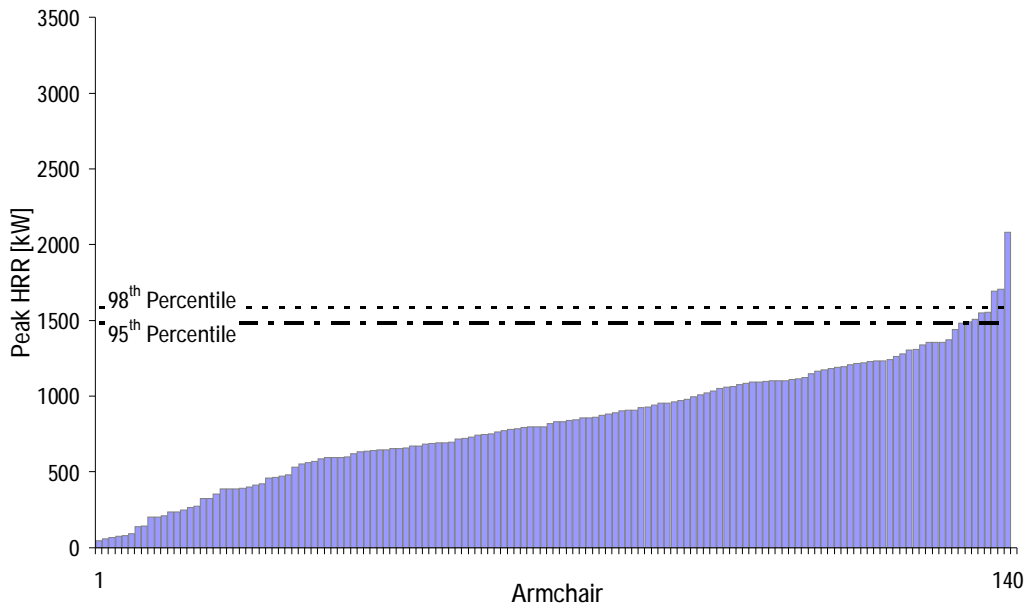

Figure 7-3: Peak HRR for Armchairs

Armchairs	
Percentile	HRR [kW]
98th	1,586
95th	1,483
90th	1,313
85th	1,227
80th	1,173
70th	1,067
60th	925
50th	825

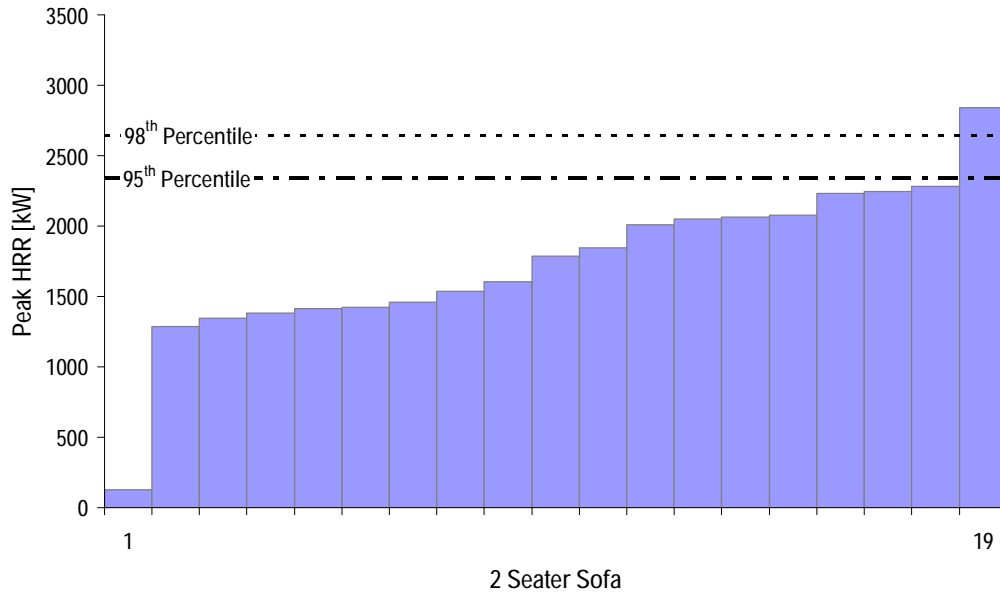

Figure 7-4: Peak HRR for 2-Seater Sofas

2 Seater Sofas	
Percentile	HRR [kW]
98th	2,643
95th	2,341
90th	2,255
85th	2,235
80th	2,139
70th	2,060
60th	1,978
50th	1,785

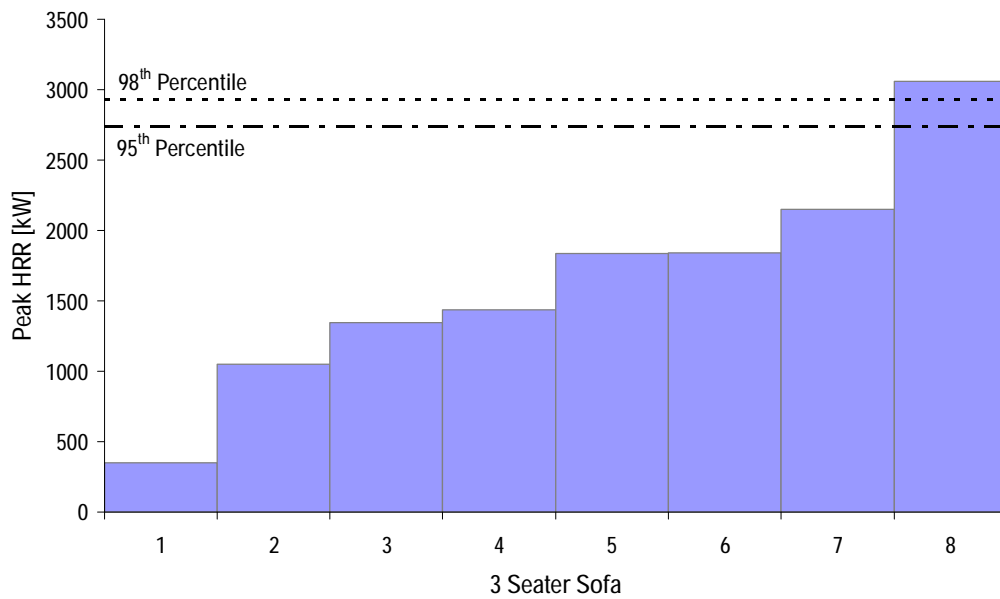

Figure 7-5: Peak HRR for 3-Seater Sofas

### 3 Seater Sofas

Percentile	HRR [kW]
98th	2,933
95th	2,743
90th	2,426
85th	2,138
80th	2,029
70th	1,842
60th	1,840
50th	1,640

While the sample size significantly decreases from armchairs (140) to 2-seaters (19) and further again with data available for 3-seaters (8), there are still visible trends. As the size of the upholstered furniture item increases from an armchair to a 2-seater to a 3-seater, so does the peak HRR (Table 7-2). This correlation between the increase in chair size and the increase in peak HRR was also observed during the CBUF study (Sundström (1994).

Table 7-2: Summary of Results for Peak HRR calculated for Data

	95 <sup>th</sup> percentile [kW]	98 <sup>th</sup> percentile [kW]
Armchair	1483	1586
2-seater	2341	2643
3-seater	2743	2933

This can be attributed to a greater fuel load and the burning characteristics of upholstered furniture items, specifically the formation of a liquid pool fire of foam under the chairs. Video footage from Denize (2000) clearly showed pool fire behaviour under the burning armchair. This burning behaviour had also been observed in a number of other experiments as discussed in Chapter 3. A pool fire increases the fuel area and therefore the maximum burning rate, resulting in a higher peak HRR. As the size of the furniture item increases so does the foam mass and the potential for a larger pool fire.

There are more data sets for armchair fires and therefore it is the best data to use to determine whether there are any trends, which can be defined statistically, below in Figure 7-6 and Figure 7-7 is the distribution of the peak HRR data for armchairs and the best fit distribution curve. In this case the best statistical fit was a normal distribution.



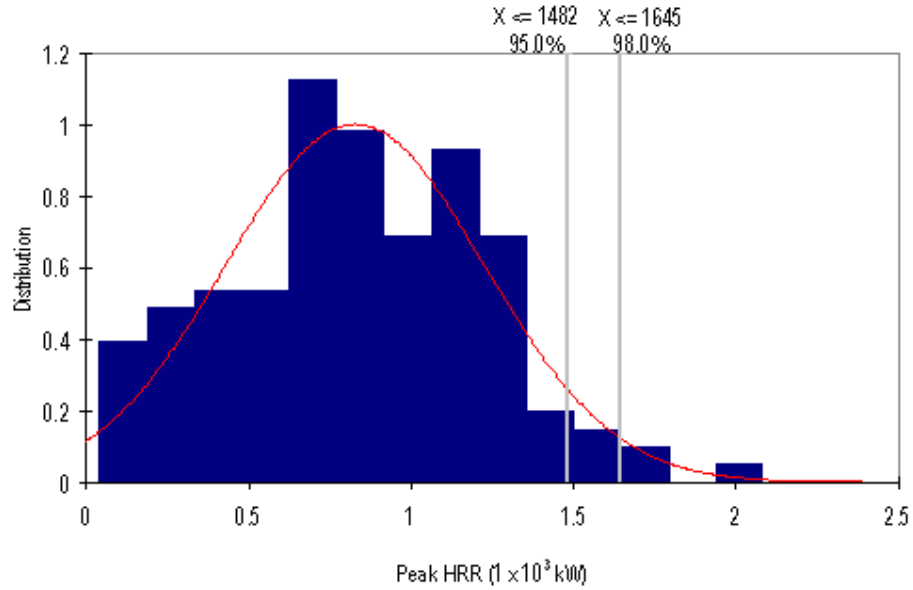

Figure 7-6: Distribution Curve of Armchair Peak HRRs – Experimental Data and Normal Curve

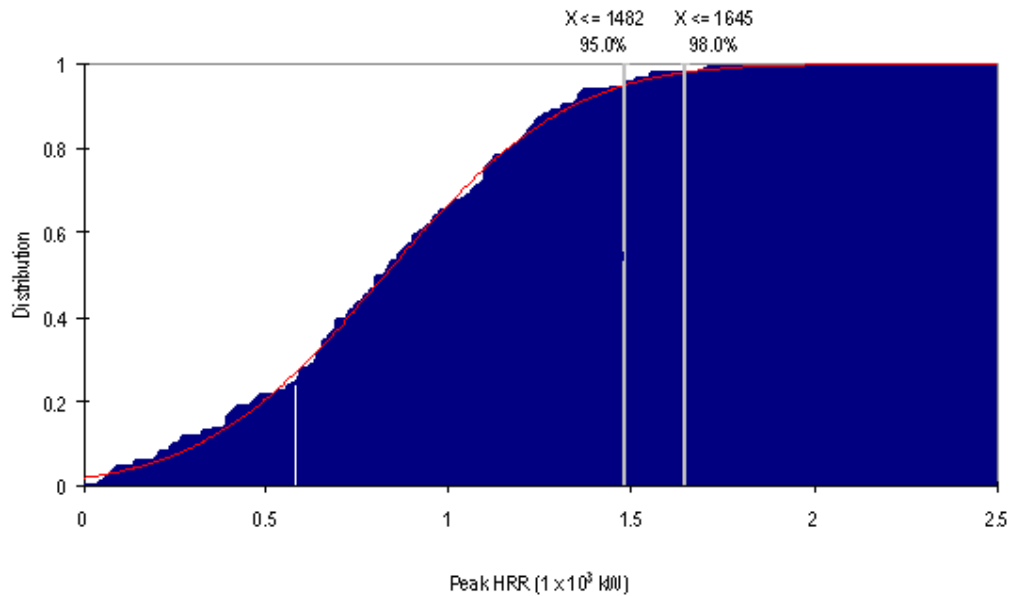

Figure 7-7: Distribution Curve of Armchair Peak HRRs – Data as a Cumulative Distribution

The cumulative fit in Figure 7-7 is much better than the normal distribution in Figure 7-6. However the normal distribution still shows there was a distinct mean value around 826 kW and the distribution of the higher values appeared to fit the normal distribution well.

As the furniture items increased in size the data set decreasing, resulting in more uncertainty in the distribution curve fitting. However from the figures above, Figure 7-3 to Figure 7-5, the data appears to be following an expected distribution with a large proportion of tests with peak HRRs within a mean value and a few furniture items at the extremes with either very high or very low peak HRRs. Below in Table 7-3 the results from the BestFit analysis have been compared to the analysis of the experimental results summarised in Table 7-2.

Table 7-3: Comparison of Peak HRR Results using Experimental Data and Distribution Fitting

[kW]	Experimental Data		Distribution	95 <sup>th</sup> percentile	98 <sup>th</sup> percentile
	95 <sup>th</sup> percentile	98 <sup>th</sup> percentile			
Armchair	1483	1586	Normal	1482	1645
2-seater	2341	2643	Logistic	2632	2912
3-seater	2743	2933	Logistic	2859	3258

The distribution curves tended to predict higher 95<sup>th</sup> percentile and 98<sup>th</sup> percentile peak HRRs compared to those calculated from the experimental data. In terms of conservatism the distribution curves gave more conservative results. However the uncertainty associated with the distribution curves and the uncertainty in the goodness of fit, given the small sample sizes, has resulted in the statistical analysis of the experimental data, rather than the distribution curves, being used in the design fire recommendations. For peak HRR for individual furniture items these recommendations correspond to the 98<sup>th</sup> percentile being:

- Armchairs            1586 kW
- 2-seater sofas      2643 kW
- 3-seater sofas      2933 kW

### 7.3.2 Time to Peak HRR

The time to peak HRR gives an indication of the growth rate of the fire. The fire is more severe when the time to peak HRR is shorter. At the 95<sup>th</sup> and 98<sup>th</sup> percentiles, 95% and 98% of the data sets are yet to reach the peak HRRs, respectively. The difference between the 95<sup>th</sup> percentile and the 98<sup>th</sup> percentile was less definitive when comparing time to peak HRR data, as shown in the results found for armchair tests in Figure 7-8.

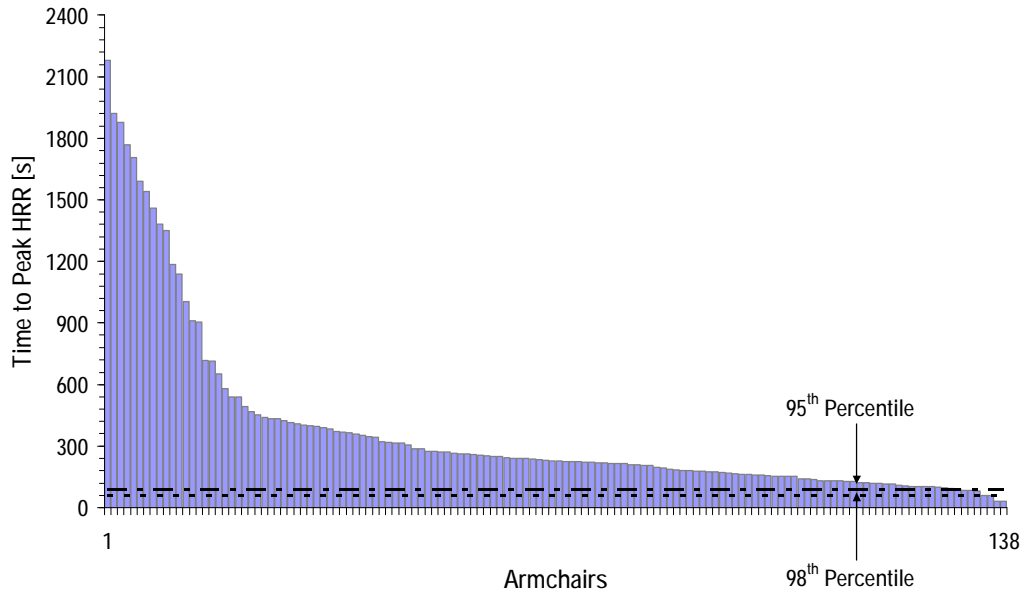

Figure 7-8: Time to Peak HRR for Armchairs

Armchairs	
Percentile	Time to peak HRR [s]
98th	60
95th	91
90th	103
85th	121
80th	132
70th	165
60th	204
50th	228

The range of values for time to peak HRR was very large ranging from less than a minute to over 30 minutes. The time to peak HRR can have significant implications in a design fire and conclusions made from time to peak HRR data needs to be assessed with care, as there are different ways to measure time to peak HRR. In some experiments time = 0 when the ignition source was started. In other experiments time = 0 was taken once the HRR of the fire reached a certain level, for example; the time of ignition or when the HRR was 50 kW, or 100 kW. The conditions for time = 0 are not always stipulated, and may incorporate some or all of the incipient stage.

The aim of the time to peak HRR data in this research was to use it as an indication of the fire growth rate and it was not intended to incorporate the incipient stage. Below in Figure 7-9 are the results from the 2-seater data.

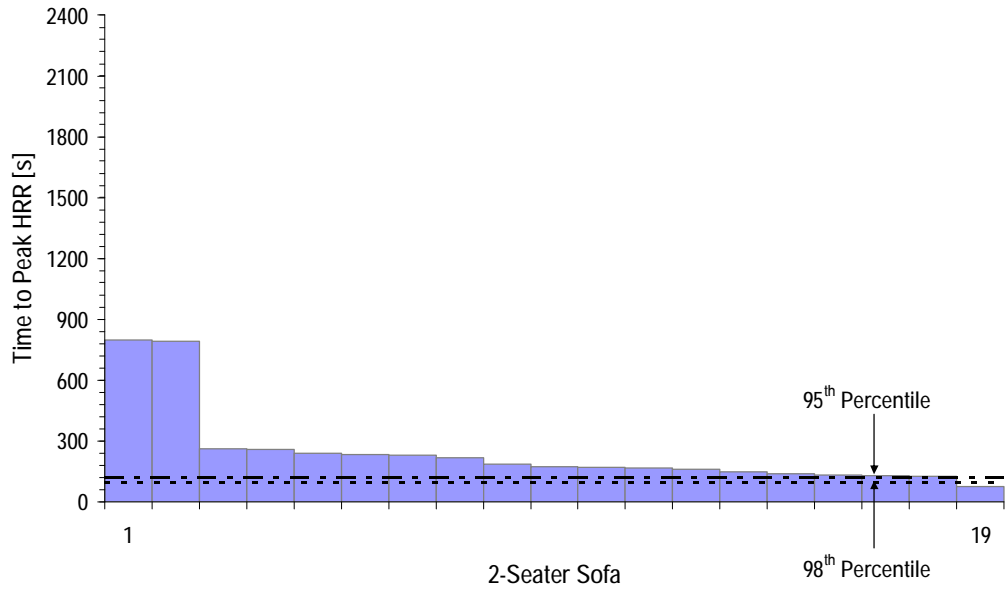

Figure 7-9: Time to Peak HRR for 2-seater Sofas

2 Seater Sofas

Percentile	Time to peak HRR [s]
98th	93
95th	119
90th	128
85th	132
80th	136
70th	154
60th	168
50th	173

It appears the method of assessing the time to peak HRR was more consistent compared to the armchair data. The time to peak HRR at the 95<sup>th</sup> and 98<sup>th</sup> percentiles appears to be slightly more than the armchair data, as can be seen in Table 7-4, which shows the 95<sup>th</sup> and 98<sup>th</sup> percentiles of time to peak HRR for the other types of furniture.

Table 7-4: Summary of Results for Time to Peak HRR

	95 <sup>th</sup> percentile [s]	98 <sup>th</sup> percentile [s]
Armchair	90	60
2-seater	120	93
3-seater	154	148

The trend of increasing time to peak HRR as the furniture item increased in size as expected, as the test typically started with an ignition source within the same magnitudes, therefore initially having the same growth rates. The peak HRR increased as the furniture increased and it therefore follows that the time to peak HRR would increase as it would take longer to reach a larger peak HRR.

The time to peak HRR data was also analysed with BestFit, with a summary of results in Table 7-5.

Table 7-5: Comparison of the Time to Peak HRR Results using Experimental Data and Distribution Fitting

[s]	Experimental Data		Distribution	95 <sup>th</sup> percentile	98 <sup>th</sup> percentile
	95 <sup>th</sup> percentile	98 <sup>th</sup> percentile			
Armchair	90	60	Log-Logistic	71	52
2-seater	120	93	Log-Logistic	96	84
3-seater	154	148	Inverse Gaussian	147	139

The distribution curves tended to predict shorter 95<sup>th</sup> percentile and 98<sup>th</sup> percentile times to peak HRR compared to those calculated from the experimental data. As with the Peak HRR data in terms of conservatism the distribution curves gave more conservative results. However the uncertainty associated with the distribution curves and the uncertainty in the goodness of fit, given the small sample sizes, has resulted in the statistical analysis of the experimental data, rather than the distribution curves, being used in the design fire recommendations. For time to peak HRR for individual furniture items these recommendations correspond to the 98<sup>th</sup> percentile being:

- Armchairs        60 s
- 2-seater sofas    93 s
- 3-seater sofas    148 s

### 7.3.3 Total Heat Released

The Total Heat Released (THR) was the amount of energy released during the combustion of the furniture item. For a number of the datasets the THR has been quoted from the original reference, where the THR was unavailable it was calculated as follows: The HRR was plotted with respect to time and an approximate the integral was calculated using a numerical solution. The area under the HRR curve was calculated by creating rectangles with the time steps and the average HRR between each time set.

Figure 7-10 is a graphical representation of the THR for the different furniture items and the 98<sup>th</sup> percentile for each classification of furniture item.

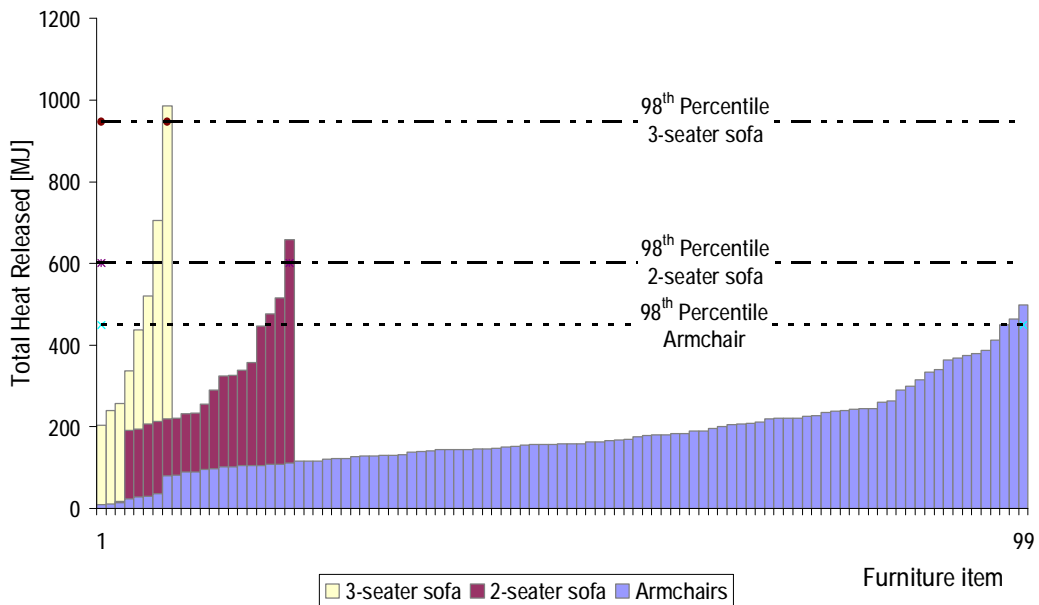

Figure 7-10: Total Heat Released of Upholstered Furniture

Total Heat Released [MJ]			
Percentile	Armchairs	2 Seater Sofas	3 Seater Sofas
<b>98th</b>	450	601	947
<b>95th</b>	379	515	888
<b>90th</b>	334	476	789
<b>85th</b>	261	447	695
<b>80th</b>	238	357	631
<b>70th</b>	208	326	512
<b>60th</b>	180	289	454
<b>50th</b>	158	233	387

The 95<sup>th</sup> percentile was not displayed in Figure 7-10 for clarity, as there was little discrepancy between the 95<sup>th</sup> and 98<sup>th</sup> percentiles. There is a trend that the THR increased as the furniture size increased. As with the other characteristic the armchair data is the only furniture size which has a large enough sample size to be interpreted in a quantitative manner statistical.

Table 7-6 shows the 95<sup>th</sup> and 98<sup>th</sup> percentiles of THR for the different furniture items.

Table 7-6: Summary of Results for THR

	95 <sup>th</sup> percentile [MJ]	98 <sup>th</sup> percentile [MJ]
Armchair	379	450
2-seater	515	600
3-seater	888	980

As expected, the THR increases with the size of the furniture item due to the increase in combustible fuel. From the small sample shown above this trend was greater than linear. There are a number of different reasons that could explain this trend, for example, pool burning behaviour compounding with the increase in combustible fuel. The THR data was also analysed with BestFit, with a summary of results in Table 7-7

Table 7-7: Comparison of the Total Heat Released Results using Experimental Data and Distribution Fitting

[MJ]	Experimental Data		Distribution	95 <sup>th</sup> percentile	98 <sup>th</sup> percentile
	95 <sup>th</sup> percentile	98 <sup>th</sup> percentile			
Armchair	379	450	Log-Logistic	360	448
2-seater	515	600	Logistic	515	658
3-seater	888	980	Pearson Type V	1308	2199

The distribution curve fitted to the armchair data gave comparable 95<sup>th</sup> and 98<sup>th</sup> percentiles, giving more confidence in the distribution curve, compared to some of the other fits. As the sample size decreased for the 2-seater sofa and 3-seater sofa the distribution curves deviated from the experimental data. As illustrated by the THR sample size for the 3-seater sofa the THR varied appreciably between each data set. The extremes of the small sample set then had a disproportionate influence on the fitted distribution curve. Therefore the experimental data, rather than the distribution curves, were used in the design fire recommendations. For the THR for individual furniture items these recommendations correspond to the 98<sup>th</sup> percentile being:

- Armchairs 450 MJ
- 2-seater sofas 600 MJ
- 3-seater sofas 980 MJ

### 7.3.4 Maximum CO/CO<sub>2</sub> ratios

For a qualitative comparison of maximum CO/CO<sub>2</sub> ratios between free burn and compartment fires there were five experiments with the data available for analysis. Denize (2000) recorded the maximum

CO/CO<sub>2</sub> ratio in free burn conditions. The maximum ratio ranged from 0.002 to 0.011, with an average CO/CO<sub>2</sub> ratio of 0.006.

### 7.3.5 Beds and Bedding

As discussed previously in this chapter there are not enough test results to recommend a design fire for bedding assemblies. However from the available test results the most severe fire characteristics Ohlemiller et al. (2000) have been quoted below. As a guide it is recommended that values used in design fires should be:

- Peak HRR - not less than 3.85 MW
- Time to Peak HRR - not more than 305 s

### 7.3.6 Free-burn Design Fires

The analysis of each of the variables in isolation has been used to produce over all design fire HRR curves for each furniture item. When the recommended values for time to peak HRR are considered with the peak HRR and fitted to a t<sup>2</sup>-fire curve the results translate in to the  $\alpha$  - growth rates below:

- Armchairs 0.441 kW/s<sup>2</sup>
- 2-seater sofas 0.306 kW/s<sup>2</sup>
- 3-seater sofas 0.134 kW/s<sup>2</sup>

A preliminary design fire for each furniture item has been developed using the growth rate specified above and the recommendations for THR to create a design fire curve with HRR with respect to time. The HRR curve has a t<sup>2</sup> growth rate up to the recommended peak HRR then a period of steady state burning until the THR reaches the recommendations of Section 7.3.3. The results are shown graphically for each furniture item below in Figure 7-11.



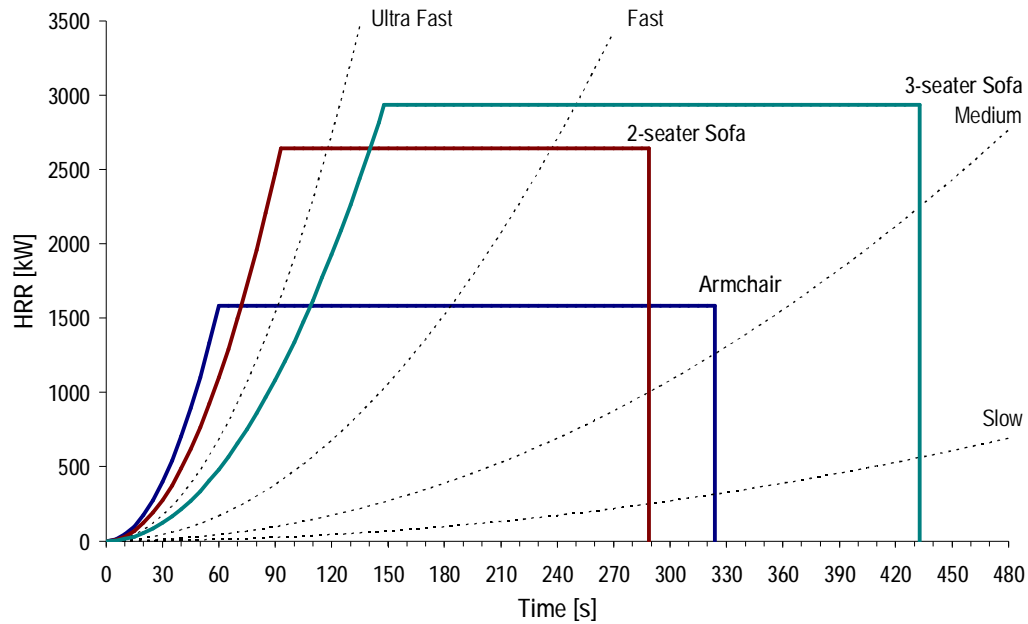

Figure 7-11: Preliminary Design Fires for Upholstered Furniture Items

The growth rate of the armchair fire is faster than the 2-seater and 3-seater sofas; however has a lower peak HRR and shorter duration. The peak HRR increases with furniture size, however this increase is not proportional to the increase in size, as can be seen in the relatively small increase between a 2-seater sofa and 3-seater sofa. The duration of the 2-seater sofa has the shortest duration using the results from the statistical analysis.

## 7.4 Compartment Effects

To investigate compartment effects, an identical furniture item was burnt in both the free burn and room burn test. Most of the room tests were conducted in an ISO 9705 room (2.4 m x 3.6 m x 2.4 m high). The ISO room is small compared to an average room size, but is often considered the worst-case scenario. This is because the compartment effects are more pronounced due to the close proximity of the walls to the fire. Unfortunately data sources were limited to CBUF, University of Canterbury and a few experiments from NIST. The variables analysed were:

- Peak HRR [kW]
- Time to peak HRR [s]
- Total heat released (THR) [MJ]
- Effective heat of combustion ( $H_{eff}$ ) [MJ/kg]

From the University of Canterbury experiments it was possible to do a very small study on the compartment effects on maximum CO/CO<sub>2</sub> ratios.

The data available for analysis is summarised in Table 7-8. Each data set represents a pair of free burn/ room burn tests.

Table 7-8: Data Used in Determining Compartment Effects

Variable of Interest	Number of data sets
Peak HRR	45
Time to peak HRR	43
Effective heat of combustion	37
Total heat released	37
Max. CO/CO <sub>2</sub>	5

As with the free burn characteristics the compartment effects were analysed statistically by analysing the experimental data and using BestFit to fit distribution curves. Results have been presented graphically as a distribution of input data and the BestFit distribution curve overlaid. The 98<sup>th</sup> percentile has been calculated using two different methods; the first is the 98<sup>th</sup> percentile of the input data, the second is the 98<sup>th</sup> percentile of the distribution curve. The sample size for analysis of compartment effects was even smaller than the free burn characteristics; therefore the distribution curves are more for interest and are not considered in the design fire recommendations.

#### 7.4.1 Peak HRR

As stated in Table 7-8 there were 45 pairs of free burn/ room burn experiments, the majority coming from the 1994 CBUF study. To calculate the affect of the compartment a percentage difference was calculated in terms of an increase in peak HRR when the object was ignited in a room compared to the furniture calorimeter (Equation 6).

$$Peak\_HRR\ \%_{increase} = \frac{(Peak\_HRR_{Room}) - (Peak\_HRR_{Free})}{Peak\_HRR_{Free}} \times 100$$

Equation 6

The distribution of all the results, regardless of furniture size, is shown below in Figure 7-12. In calculating the 98<sup>th</sup> percentile in the difference in peak HRR there were two outlying points filtered from the sample set. Data was filtered if the points lay beyond two standard deviations of the mean. From the data set for peak HRR two tests were excluded. Both tests represented rare events, which do not represent severe increases in peak HRR in a flaming fire. Both were smouldering fires, which did not

progress to flaming combustion in the free burn tests but did progress to flaming combustion in the room tests. The difference in peak HRR between in these two cases were 270% and 417%.

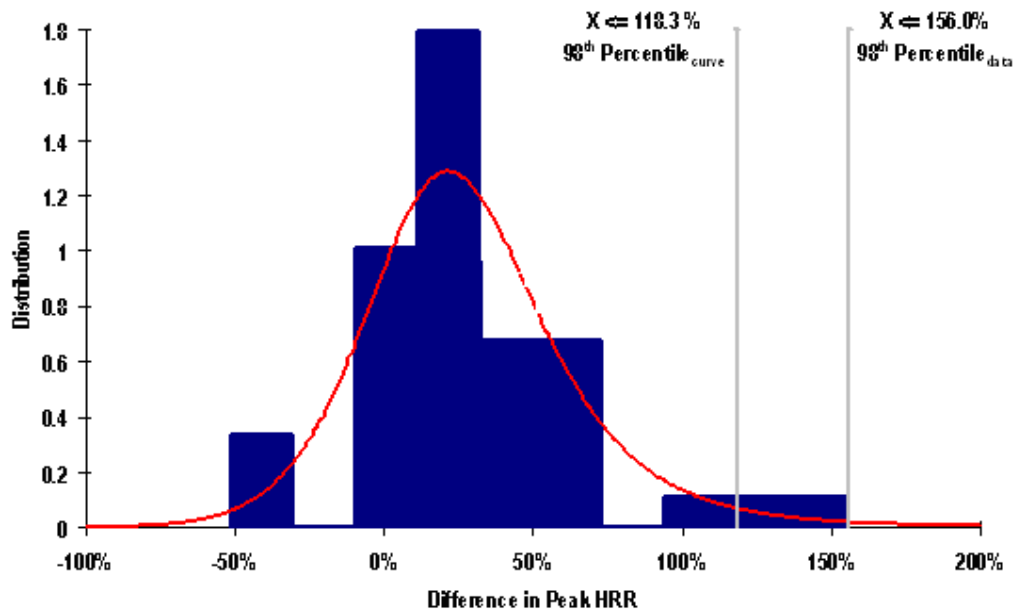

Figure 7-12: Distribution of changes to Peak HRR between free burn and room burn experiments

Figure 7-12 shows the majority of furniture items in the distribution had between a 0% and 50% increase in peak HRR when the room tests were compared to the free burn tests. It was also noted that only a few data sets showed a decrease in peak HRR when the item was in a room test compared to a free burn test.

The 98<sup>th</sup> percentile of the input data was 156 % compared to the 98<sup>th</sup> percentile of the distribution curve, 118 %. More data sets are required to establish whether the data fit the Log-Logistic distribution fitted to the input data.

To be conservative the increase on the 98<sup>th</sup> percentile was considered, this was an increase of 156%. The distribution curve fit to the input data had a lower increase at the 98<sup>th</sup> percentile. If a single item was to burn in a larger room it is unlikely the peak HRR would increase by this much. The walls and ceiling would be further from the fire causing less radiation feedback. However a small test room is not unrealistic when considering the increase in apartment accommodation where room sizes are typically smaller than traditional rooms in houses.

## 7.4.2 Time to Peak HRR

Similarly the decrease in time to HRR was calculated using Equation 7:

$$Time\_Peak\_HRR_{decrease}\% = \frac{(Time\_Peak\_HRR_{Room}) - (Time\_Peak\_HRR_{Free})}{Time\_Peak\_HRR_{Free}} \times 100$$

Equation 7

The distribution of the results is shown in Figure 7-13. In calculating the 98<sup>th</sup> percentile in the difference in time to peak HRR data was filtered if the points lay beyond two standard deviations of the mean. In this data set there was one outlying data point that was removed. This item smouldered in the furniture calorimeter test and self-extinguished, but in the room test the smouldering eventually led to flaming combustion. The increase in time to peak HRR was 500%, or six (6) times that of the self-extinguishing free burn item. This is a rare event which leads to less severe consequences in terms of flaming fires, as increases in time to peak HRR corresponds to a slower growing fire.

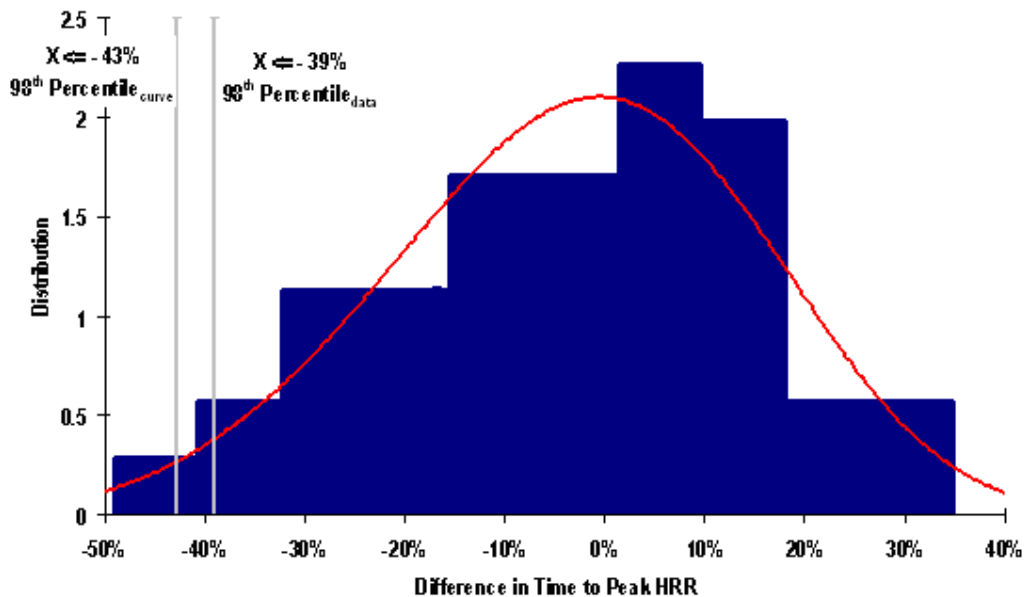

Figure 7-13: Distribution of changes in Time to Peak HRR between free burn and room burn experiments

In terms of the time to peak HRR, a decrease in time represents a faster fire growth rate. A negative percentage represents a fire, which had a faster growth rate in a room burn compared to the corresponding test in a free burn test. All the data tested showed a change in time to peak HRR of  $\pm 50\%$ , except the single outlying point.

The Weibull distribution curve results in a 43% decrease in the time to peak HRR at the 98<sup>th</sup> percentile. In terms of  $t^2$ -fires, a 43% decrease in time to peak HRR is significant enough to change the growth rate of the fire from, for example; a medium to fast fire. By applying these results to the indicative results given in Table 7-4 the same armchair fires in a room could result in over half the fires having fast to ultra fast growth rates, or greater than ultra fast growth rate.

### 7.4.3 Total Heat Released and Effective Heat of Combustion

Changes in Total Heat Released (THR) and Effective Heat of Combustion ( $H_{eff}$ ) were calculated in the same manner as peak HRR and time to peak HRR. Figure 7-14 shows the distribution of results comparing the THR of room burns and free burns. Figure 7-15 shows the distribution of the difference in effective heat of combustion of room burns and free burns.

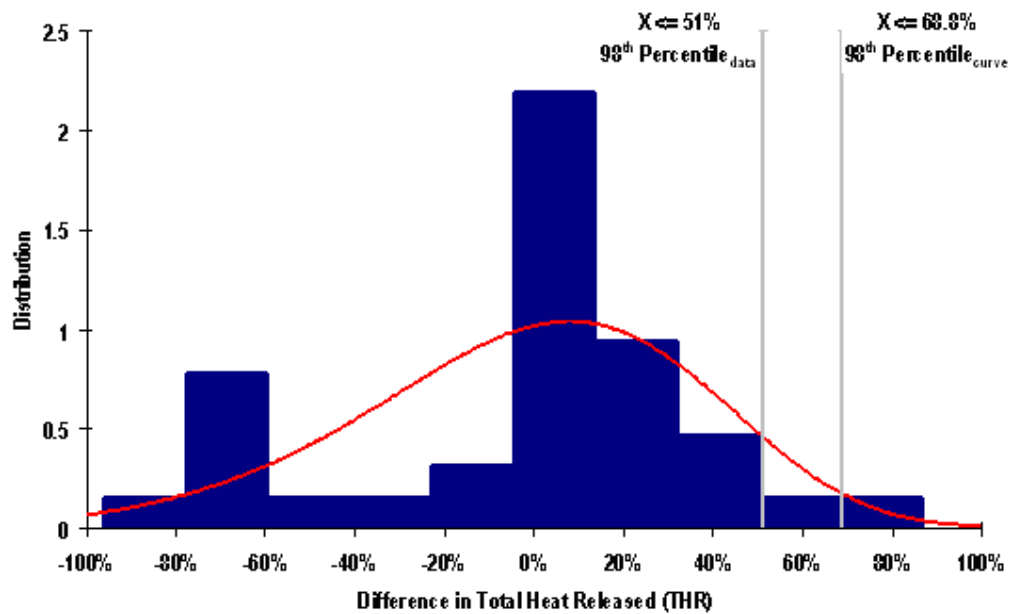

Figure 7-14: Distribution of changes in Total Heat Released between free burn and room burn experiments

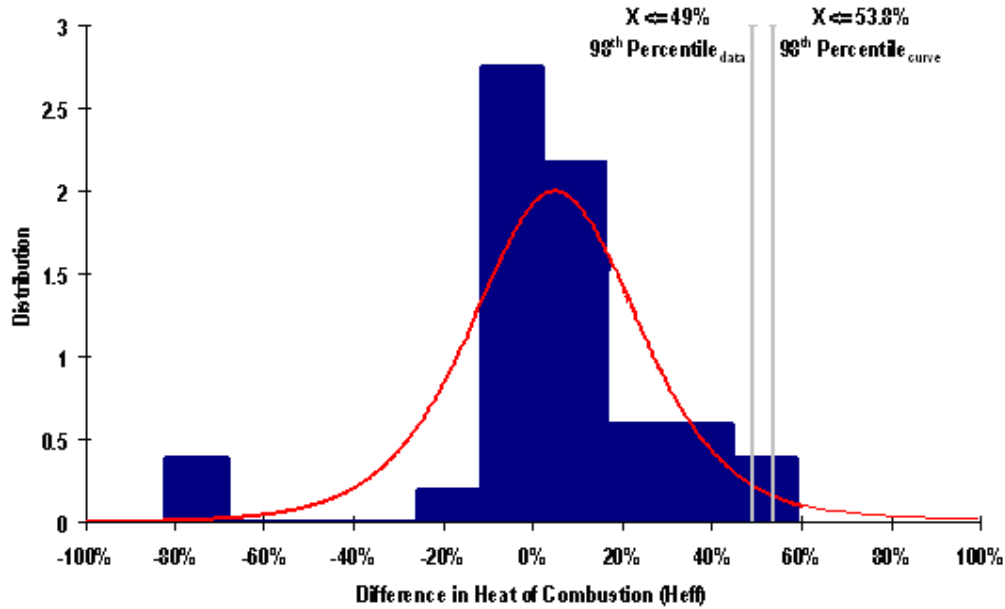

Figure 7-15: Distribution of changes in Effective Heat of Combustion between free burn and room burn experiments

Again the out lying data points were excluded from the statistical analysis which resulted from the same data set (experimental pair) excluded from the peak HRR and time to peak HRR. An increase in THR indicates more of the available combustible fuel was consumed in the fire in the room test. The majority of tests showed a change in total heat release rate (THR) of  $\pm 37\%$ . The 98<sup>th</sup> percentile was a 51% increase in THR from the data and a 69% increase from the Weibull distribution. The even distribution, excluding the outlier, suggests there was no trend towards an increasing THR. The THR would not be expected to change significantly when total burnout has occurred in the free burn case. The increased THR can be attributed to items that self extinguished and did not completely burnout in the free-burn cases.

The effective heat of combustion is calculated by dividing the THR by the mass loss of the furniture item. There was not expected to be an appreciable difference in the effective heat of combustion given the THR and the mass loss are dependant on each other. Therefore the result that the distribution of differences in effective heat of combustion was around the no change (0%) point was expected. The 98<sup>th</sup> percentile saw an increase of 49%. Again this can be attributed to items with very limited burning in the free burn case and more combustion in the room tests promoted by compartment effects like radiation enhancement.

#### **7.4.4 Maximum CO/CO<sub>2</sub> ratios**

The production of CO is directly related to the amount of oxygen required in the combustion process. In fully ventilated fires with excess oxygen there is little CO produced. In room burns where the fire is ventilation limited the CO production increases as the oxygen concentration decreases, due to incomplete combustion.

The dependence of CO concentration on the type of furniture and the room configuration would be useful, as CO is an important variable when determining tenability. The CO/CO<sub>2</sub> ratios were measured for five data sets conducted at the University of Canterbury. The increases in maximum CO/CO<sub>2</sub> ratios between free burn and room burn experiments varied from 10 times to 50 times. The sample size was too small (five data sets) to make any conclusions except for the observation that there is a significant increase in CO production in room burns.

Details of the exact ventilation conditions are necessary in order to determine CO concentration. Typically the stoichiometric ratio is input into a computer model and a combustion model is used to determine the CO concentrations for a given fire scenario. These have been determined for well-known fuels, such as wood, ethanol or polyurethane. There are limited results on the combustion stoichiometry of complex fuels or combinations of different fuels, as is typically found in, for example, an armchair, which contains fabric, foam and wood. This can be further extended to a room scenario which contains upholstered furniture, wooden furniture and fittings and appliances containing large quantities of plastic. By using experimental results, empirical stoichiometric ratios could be established for common fuel packages, such as armchairs.

#### **7.4.5 Beds and Bedding**

As discussed previously in this chapter there are not enough test results to recommend a design fire for bedding assemblies. However from the available test results the most severe fire characteristics Ohlemiller et al. (2000) have been quoted below. As a guide it is recommended that values used in design fires in a compartment should be:

- Peak HRR - not less than 4.62 MW
- Time to Peak HRR - not more than 334 s

#### **7.4.6 Compartment Design Fires**

The characteristics determined in the free burn analysis were increased by the percentages determined in Section 7.3 to give the following recommendations (Table 7-9) for compartment design fires.

Table 7-9: Data Compartment Design Fire

Furniture Item	Compartment Characteristic		
	Peak HRR [kW]	Time to Peak HRR [s]	THR [MJ]
Compartment Adjustment	156%	- 39%	51%
Armchair	4060	37	679.5
2-seater Sofa	6766	57	906.0
3-seater Sofa	7508	90	1479.8

The next series of figures (Figure 7-16 to Figure 7-19) show the preliminary design fires for the upholstered furniture compartment fires. Figure 7-16 compares the three different furniture types, Figure 7-17 to Figure 7-19 compare the free burn design fire with the compartment design fire.

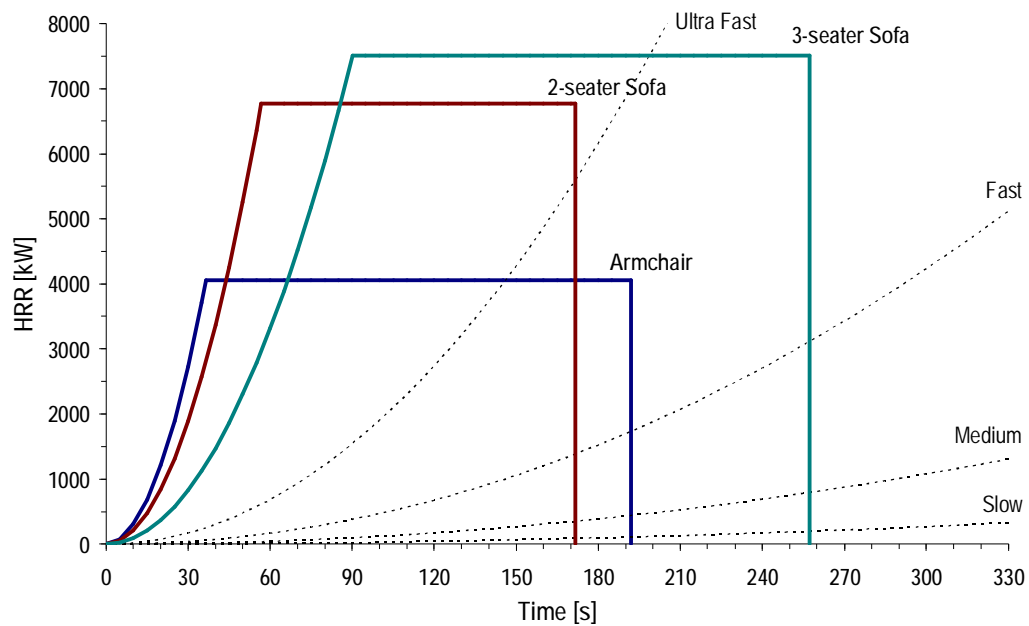

Figure 7-16: Preliminary Compartment Design Fires for Upholstered Furniture Items



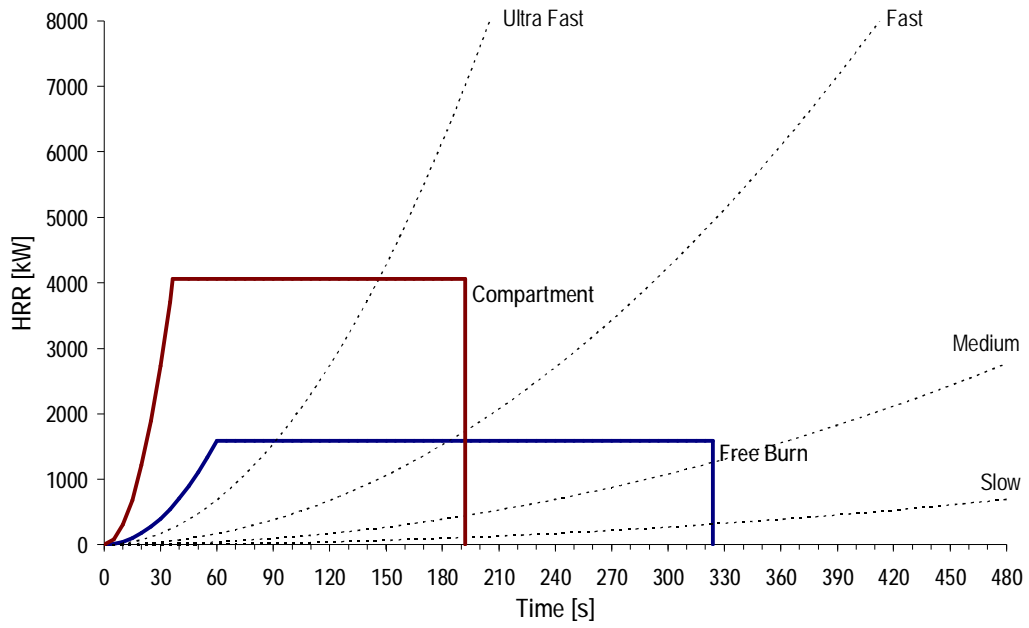

Figure 7-17: Preliminary Design Fires for Armchairs

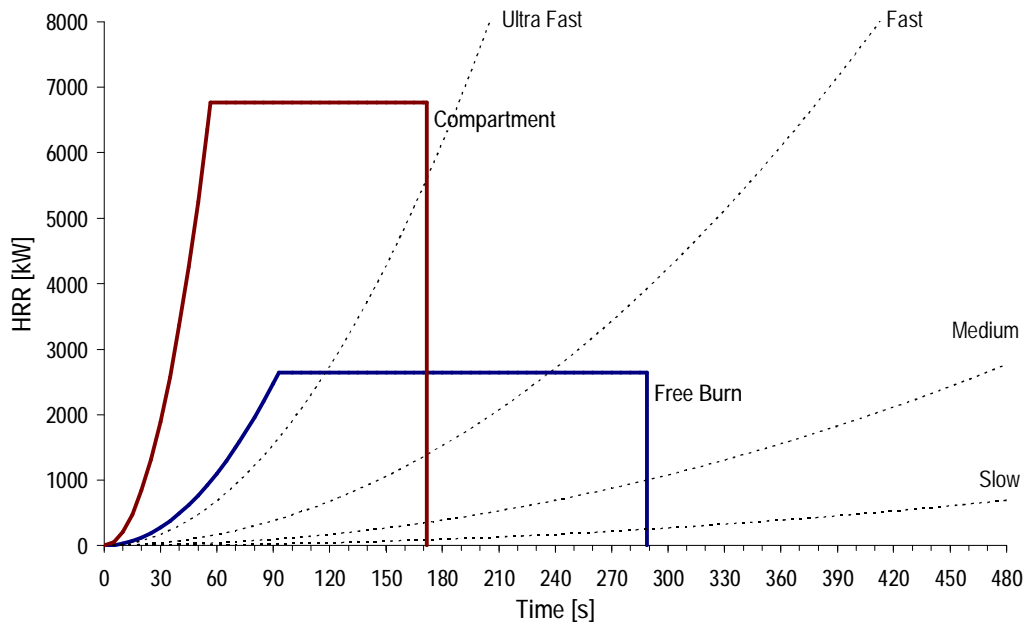

Figure 7-18: Preliminary Design Fires for 2-seater Sofas

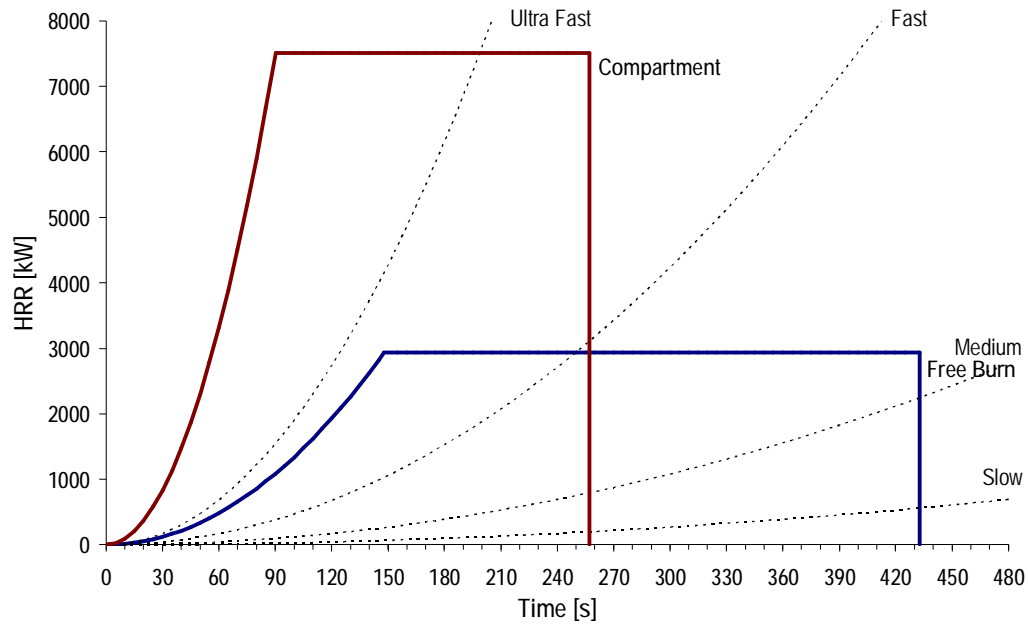

Figure 7-19: Preliminary Design Fires for 3-seater Sofas

The increases due to the compartment effects result in a significantly faster growth rate and peak HRR; however the duration of the fire was appreciably reduced. The adjustments to the design fires to account for compartment effects at this stage is rather crude, all furniture items have been increased by the same percentages. Ideally each type of furniture item would be analysed separately, however there was insufficient data available to draw any conclusions for specific furniture items. Additional limitations of these results are discussed in the next section (Section 7.5).

## 7.5 Limitations

Some of the room tests were conducted in rooms with plasterboard lining on the walls and ceilings. The biggest limitation of the results using this data was that it was unclear whether the paper facing on the plasterboard was burnt off before the experiments. The presence of paper would contribute to the HRR and the total heat release rates. Fortunately the inclusion of paper would yield a conservative result in terms of giving recommendations for compartment effects.

Most of the room tests studied in this analysis were conducted in an ISO 9705 room (2.4 m x 3.6 m x 2.4 m high). An ISO 9705 room is relatively small with one door-sized opening as ventilation (0.8 m x 2.0 m high) located in one of the short walls. There are limitations with applying these results to different room sizes and different ventilation conditions. There is currently very little quantifiable research on the effects of these variables compared to a base case. Ideally sets of experiments with comparable furniture items, in the furniture calorimeter, in ISO rooms and other sized rooms with varying ventilation conditions would be conducted. However experiments would be highly expensive due to the cost of

producing full-scale furniture items and conducting the multiple full-scale tests required to collect all the data.

Full sets of data for each experiment would also aid in the standardisation of fire characteristics. It is recommended that a list of collectable outputs be compiled so future experiments can be compared in a quantitative manner. For example:

- A standard  $t = 0$  point
- HRR with respect to time
- CO and CO<sub>2</sub> concentrations with respect to time
- Soot concentration
- Starting mass
- Mass loss rate of fuel
- Total heat released
- Effective heat of combustion

There were more results for some outputs than others; most sources reported peak HRR and time to peak HRR results but very few published CO and CO<sub>2</sub> concentrations with time or even peak concentrations.

As can be seen in this chapter, there are appreciably more results available for armchairs compared with 2-seater seats and 3-seater sofas. This may be attributed to the cost of testing larger sized furniture items. This is propagated in construction or purchase of the items and also increases in the test system requirements for larger items, in terms of smoke extraction rates and upper HRR tolerances of equipment. The discrepancy in test items means statistical analysis of loveseats and sofas was indicative only, as a larger sample size would be required to obtain a statistical understanding of fire behaviour. Furthermore, there are only a few experimental results available for other furniture items and bedding assemblies. Often results from tests could not be compared, as there were too few common outputs.

The recommendations resulting from the statistical analysis of the peak HRR have been derived from the percentiles calculated using the experimental data in preference to the percentiles calculated from the distribution curves. This was because of the small sample sizes available for the statistical analysis, larger sample sizes may have resulted in more confidence of the data fits to the distribution curves. The data fitting was completed as a matter of course for all variables to identify gaps in the data sets and to establish a methodology for analysing test data for the use of developing design fires.

As can be seen in Figure 7-11 and Figure 7-16 to Figure 7-19 the preliminary design fires had growth rates faster than the  $t^2$ -fire ultra fast growth rate, and the analysis of the growth rates found that the 98th percentile was between the fast and ultra fast growth rates. The difference in results has been attributed to the growth rates study including the incipient stage in the growth phase. With the time to peak HRR data it was not always obvious whether the incipient phase was included; however given the discrepancy in results it could be assumed that the incipient stage was not included. When defining a design fire the incipient stage is still important when the design fire is used to assess tenability time within a space. Therefore it should be accounted for and further research would be required to determine parameters for an incipient stage or slower initial growth rates.

## 8 FDS Simulations

Fire Dynamics Simulator (FDS) is a Computational Fluid Dynamics (CFD) program which models fire behaviour. Uses include modelling possible fire events to ascertain what may happen in a fire; and modelling past fire events to establish a possible timeline of events. The use of FDS is steadily increasing in Fire Engineering Design for complex buildings to justify specific engineering designs.

In FDS the fire can be defined in two ways in the input file. The first is defining a HRR per unit area with respect to time, and this definition is comparable to the input in a zone model. The second method defines the heat of vaporisation and other material characteristics including, but not limited to, ignition temperature, maximum burning rate, density, and specific heat. The material products defined are then used to calculate the growth rate and the size of the fire. The stoichiometry of a defined reaction then calculates the combustion products in terms of a mixture fraction. However, only one reaction can be modelled during each simulation, so the most dominant fuel type should be selected to represent the surrounding environment.

The simulations conducted for this project were used to determine the effectiveness of using FDS to model a single furniture item and the models sensitivity to its inputs, in particular the material properties. The simulation items were based on experimental items so that the results could be compared. A relatively coarse grid (100 mm x 100 mm) was used to reduce the computation time.

### 8.1 Modelling Upholstered Chairs

Experimental results have shown that the presence of a compartment can dramatically affect fire behaviour compared to an equivalent free burn fire (Section 7.4). Therefore the choice of design fire has a significant impact on the design of a fire safety system. Factors of significance include; time for detector activation, smoke control requirements, and the effectiveness of sprinklers. The simulations attempted to realistically model the experiments in FDS using the heat of vaporisation method to determine the burning behaviour of the furniture item. There were 4 series of experiments:

- Series 1 – Preliminary upholstered chair simulation
- Series 2 – Adjusting material properties
- Series 3 – Simulating compartment effects
- Series 4 – Adjusting other simulation parameters (grid size, ignition source geometry)

### 8.1.1 Surface Properties

Before the furniture items were modelled, preliminary simulations were conducted to determine the best approach to define the combustible surfaces of the upholstered chairs. There were two design decisions required; firstly what surface properties were appropriate, and secondly how was the chair geometry to be constructed in three dimensions within the model.

To define the surface properties FDS contains a database of material surfaces each specifying combustions parameters, for example ignition temperature and maximum burning rate. These have been collated using a number of different references. As a starting point the surface properties used in the simulations are based on the surface 'UPHOLSTERY' from the FDS database, which were determined by Chen (2001) using cone calorimeter tests. The FDS database properties for 'UPHOLSTERY' are shown below in Figure 8-1.

&SURF ID	= 'UPHOLSTERY'
FYI	= 'Fleischmann and Chen, 100% acrylic'
C_DELTA_RHO	= 1.29
TMPIGN	= 280.
DENSITY	= 40.0
RGB	= 0.53,0.38,0.35
BURN_AWAY	= .TRUE.
BURNING_RATE_MAX	= 0.03
HEAT_OF_VAPORIZATION	= 1500.
HEAT_OF_COMBUSTION	= 30000. /

Figure 8-1: FDS defined surface property 'UPHOLSTERY'

For all of the series the stoichiometric reaction for the simulations was defined as 'POLYURETHANE' from the FDS database, as shown in Figure 8-2. Only one reaction can be specified in a simulation and given polyurethane is the dominant fuel source for polyurethane foam upholstered furniture it was the most appropriate reaction.

&REAC ID	= 'POLYURETHANE'
FYI	= 'C_6.3 H_7.1 N O_2.1, NFPA Handbook,
SOOT_YIELD	Babrauskas'
MW_FUEL	= 0.10
FUEL_N2	= 130.3
NU_CO2	= 0.5
NU_H2O	= 6.3
NU_O2	= 3.55
	= 7.025 /

Figure 8-2: FDS defined reaction 'POLYURETHANE'

For the second design decision a number of trial geometries were modelled, and from these simulations it was determined that the most two suitable approaches for modelling the furniture items where, to model the items as a number of solid blocks of combustible fuel, arranged in the shape of the frame and the seat and back cushions. The second approach was to model the seat cushion and the back cushion as solid blocks. Then the frame, that is the arms and the base, would be modelled with all visible surfaces specified as a 25 mm layer of combustible material, the areas obscured under the cushions were specified as inert, as shown in Figure 8-3.

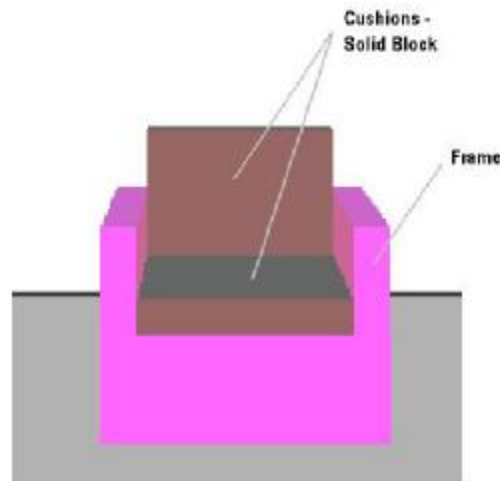

Figure 8-3: Second Modelling Approach of Armchair

The second approach was more realistic in terms of real furniture construction, because the frame of a chair is rarely constructed of solid foam. In the subsequent series only the second approach was used. The difference in properties between the solid blocks and the frame was that an extra property was defined for the frame; this was a defined material thickness 'DELTA' of 0.025 m. By defining 'DELTA' the amount of combustible fuel is defined, in conjunction with the surface density.

For Series 2 the 'UPHOLSTERY' properties were changed to better represent the material composition of the experimental chairs. In the database the material properties were those derived from cone calorimeter data by Chen (2001) for acrylic fabric / PU foam. These were replaced with new properties derived from Chen (2001) data for polyester fabric / PU foam. The combustion properties of these two fabric/ foam combinations are listed in Table 8-1. The surface property decisions are discussed further in Section 8.2.1. The polyester fabric/ PU foam was used in these simulations and represents thermoplastic fabrics.

Table 8-1: Surface Properties of Upholstery Composites

	Acrylic /PU Foam	Polyester /PU Foam
$C\Delta\rho$	1.29	1.2
$T_{\text{ignition}}$	280	265
MBR	0.03	0.03

Where:  $C\Delta\rho$  specific heat x thickness x density of the material [m]  
 $T_{\text{ignition}}$  temperature of ignition [°C]  
 MBR maximum burning rate [kg/m<sup>2</sup>/s]

### 8.1.2 Series 1

Series 1 was a set of preliminary tests, which looked at different ways of modelling upholstered furniture. The simulations were carried out in a free burn domain where all boundaries, except the ground, were open. Three different furniture items were modelled: a 3-seater sofa, 2-seater sofa and armchair.

The 3-seater sofa dimensions were based on a 3-seater sofa tested by Babrauskas, V. & Krasny (1985), more detailed sofa dimensions and details of the test published by Lawson, J. R. W. et al. (1984) helped to refine the geometry in FDS.

There were two 2-seater sofa geometries used, the first was also based on a test conducted by Babrauskas, V. & Krasny (1985) with geometry details published in Lawson, J. R. W. et al. (1984). The second geometry was based of a 2-seater sofa tested by Enright (1999). The armchair was based on a geometry widely used in fire testing of armchairs. A detailed description of dimensions can be found in CBUF Sundström (1994).

Figure 8-4 shows the dimensions of each item and their representation in FDS modified to fit the grid size used.



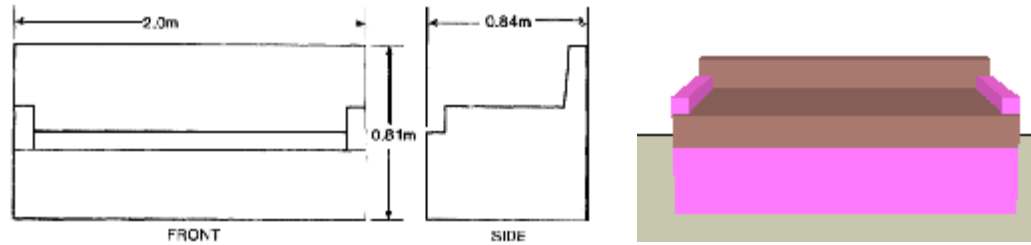

a) 3-seater sofa

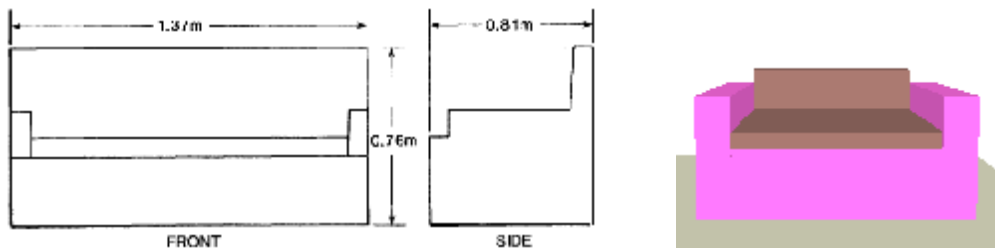

b) 2-seater sofa

**Upholstered frames**

<p>Back suspension - webbing</p> <p>Back cushion 460 x 560 x 100 mm</p> <p>Arm top foam 2 x 580 x 100 x 25 mm</p> <p>Arm front / Back foam 4 x 630 x 100 x 10 mm</p> <p>Inside arm foam 2 x 580 x 305 x 10 mm</p>		<p>Seat springs - no sag</p> <p>Seat cushion 500 x 560 x 100 mm</p> <p>Front border foam 560 x 300 x 10 mm</p> <p>Seat platform foam 560 x 500 x 25 mm</p> <p>Back support foam 560 x 520 x 25 mm</p>
---	--	---

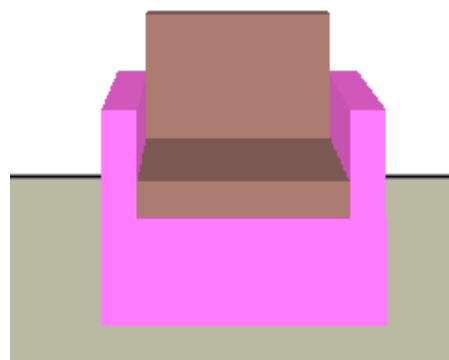

c) Armchair

Figure 8-4: Diagrammatic of experimental furniture item and FDS representation, Diagrams a) and b) extracted from Lawson, J. R. W. et al. (1984) and c) extracted from Sundström (1994)

The remaining simulations in Series 1 and the subsequent series looked specifically at the armchair geometry. The armchair was used as there was detailed experimental documentation and raw data available from the University of Canterbury and therefore the simulations could be verified. The geometry of the armchairs was of the CBUF armchair as defined by Denize (2000).

Series 1 looked at two ways of defining the armchair cushion / frame interface. Version 1 modelled a chair identical to a real chair, with solid foam cushions and upholstered surfaces on the frame. Figure 8-5 below the FDS input file for armchair Version 1.

```
*Armchair references for dimensions Denzie, H. R. (2000)
*ARMS
&OBST XB=1.4,1.5,0.9,1.5,0.3,0.6,SURF_ID6='FRAME1','FRAME1','FRAME1','FRAME1','INERT','FRAME1'/
&OBST XB=2.1,2.2,0.9,1.5,0.3,0.6,SURF_ID6='FRAME1','FRAME1','FRAME1','FRAME1','INERT','FRAME1'/

*BASE
&OBST XB=1.4,2.2,0.9,1.5,0.0,0.3,SURF_ID6='FRAME1','FRAME1','FRAME1','FRAME1','INERT','FRAME1'/

*SEAT SLAB
&OBST XB=1.5,2.1,0.9,1.4,0.3,0.4,SURF_ID='ARMCHAIR1'/

*BACK SLAB
&OBST XB=1.5,2.1,1.4,1.5,0.3,0.8,SURF_ID='ARMCHAIR1'/
```

Figure 8-5: Part of an FDS Input File, Defining the Armchair Version 1

The second definition of the chair geometry (Version 2) varied only slightly. Instead of having two combustible surfaces it incorporated the foam/ fabric layer on the top surface of the frame into the seat cushion. Thereby making the top side of the frame was made inert and the extra combustible material was added to the seat slab. This was due to a peculiarity in the way FDS calculated the combustion of the total fuel package (Discussed further in the Section 8.2.2). The armchair in the FDS input file for armchair Version 2 is shown in Figure 8-6 below.



The surfaces were specified in the FDS input file (Figure 8-7)

<b>Foam Block</b>	<b>Upholstered Frame</b>
<pre> &amp;SURF ID      = 'ARMCHAIR1' FYI           = 'Fleischmann and Chen, 100% acrylic' C_DELTA_RHO   = 1.20 TMPIGN        = 265. DENSITY       = 40.0 RGB           = 0.53,0.38,0.35 BURN_AWAY     = .TRUE. BURNING_RATE_MAX = 0.03 HEAT_OF_VAPORIZATION = 1500. HEAT_OF_COMBUSTION = 30000. /           </pre>	<pre> &amp;SURF ID      = 'FRAME1' FYI           = 'Fleischmann and Chen, 100% acrylic' C_DELTA_RHO   = 1.20 DELTA         = 0.025 TMPIGN        = 265. DENSITY       = 40.0 RGB           = 0.9,0.38,0.8 BURN_AWAY     = .TRUE. BURNING_RATE_MAX = 0.03 HEAT_OF_VAPORIZATION = 1500. HEAT_OF_COMBUSTION = 30000. /           </pre>

Figure 8-7: Part of the FDS Input File Defining the Material Properties of the Surfaces

Each property was changed in isolation and compared to the base case. The simulation inputs are presented in Table 8-3:

Table 8-3: Series 2 Simulations

Simulation	Variables		
	CDr	T <sub>ignition</sub>	MBR
Base Case	1.2	265	0.03
Case 2	→ 1.44	265	0.03
Case 3	→ 0.96	265	0.03
Case 4	1.2	→ 240	0.03
Case 5	1.2	→ 290	0.03
Case 6	1.2	265	→ 0.06
Case 7	1.2	265	→ 0.015

The armchairs modelled in FDS were simulating the chairs tested by Denize (2000). These experiments were of armchairs with the same cover fabric and different type of PU foam and were conducted under the furniture calorimeter. Figure 8-8 shows the HRR profiles the simulation results were compared to.

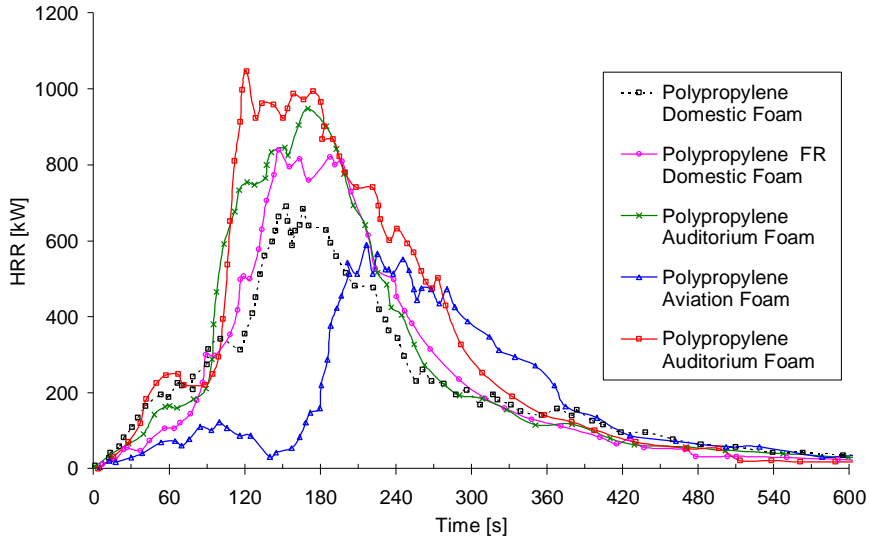

Figure 8-8: HRR profiles of Experimental Results Denize (2000) to be Compared with Simulation Results

The test with the standard PU foam/ polypropylene fabric armchair was the experimental Base Case comparison for verification of the simulations. However the simulations were also compared against the other experiments to determine whether the modified material properties could be used to represent other foam/ fabric combinations. The other experimental chairs had the same cover fabric but different types of foam. In increasing order of ignition resistance and foam density, the foams were:

- FR domestic PU foam
- Auditorium foam
- Aviation foam

### 8.1.4 Series 3

Series 3 looked at the ability of FDS to model compartment effects. The armchairs modelled in Series 2 (Base case to Case 7) were then modelled in the ISO room geometries. Figure 8-9 shows the Series 2 and Series 3 set-up in FDS.

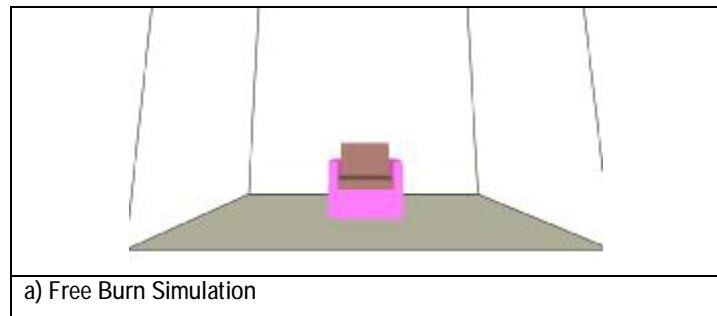

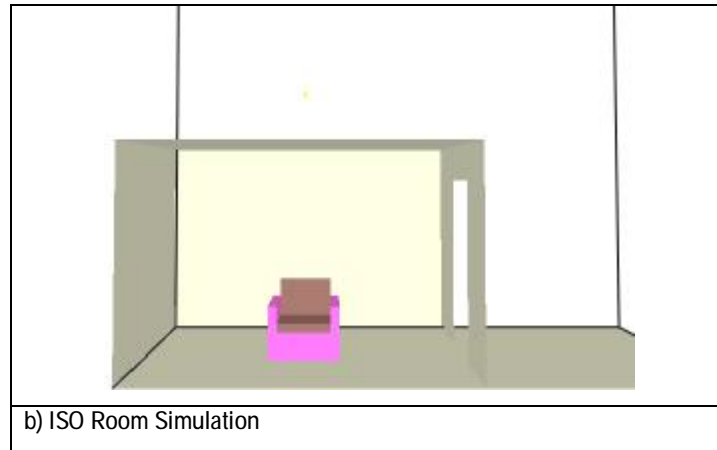

Figure 8-9: FDS Simulation Comparisons – Free Burn, ISO Room

Each case was compared with the corresponding Series 2 test. The ISO room simulations were also compared with experimental results from Girgis (2000). The items tested by Denize (2000) and Girgis (2000) were of the same construction and used the same material but were tested under different conditions, in the furniture calorimeter and in the room calorimeter respectively. The HRR profiles of the experiments used for the ISO room verifications are shown below in Figure 8-10.

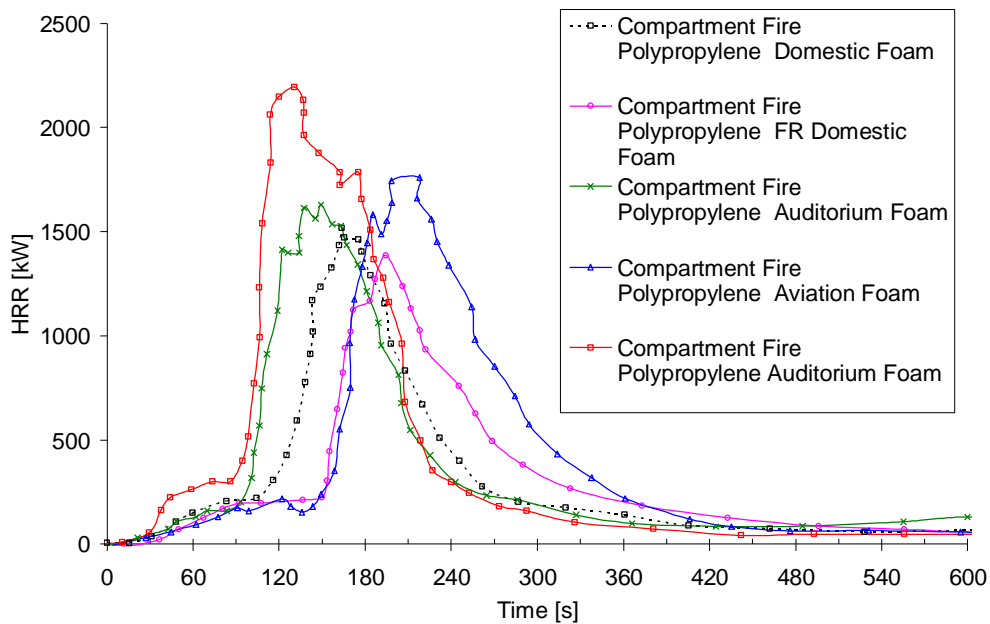

Figure 8-10: HRR profiles of Experimental Results from Room Calorimeter Tests Girgis (2000) to be Compared with ISO Room Simulation Results

### 8.1.5 Series 4

Series 4 was a qualitative analysis of the sensitivity of FDS when modelling single item upholstered furniture fires. A small study of the effects of simulation parameters in free burn conditions was

conducted, specifically changing the ignition source dimensions and grid size. The base case had a 100 mm grid size and the ignition source was a 30 kW burner with dimensions 200 mm x 200 mm.

The ignition source was maintained at a total HRR of 30 kW but the following variations were simulated:

- The grid size was altered in Case 8 from 100 mm x 100 mm to:

Case	Grid Size
Case 8a	80 mm x 80 mm
Case 8b	60 mm x 60 mm
Case 8c	50 mm x 50 mm
Case 8d	40 mm x 40 mm

The base case burner was used in each case.

- The original grid size was used and the burner size increased from 200 mm x 200 mm to 300 mm x 300 mm square with the same heat output (30 kW). (Case 9)
- The grid size was decreased from 100 mm x 100 mm to 50 mm x 50 mm, and a square ring burner was modelled, 300 mm x 300 mm with inner dimensions of 200 mm x 200 mm, 30 kW heat output. (Case 10)

The different grid sizes and burners are shown below in Figure 8-11.



			
Base Case		Case 8	
Burner:	200 mm x 200 mm	Burner:	200 mm x 200 mm
Grid:	100 mm x 100 mm	Grid:	Multiple Cases
			
Case 9		Case 10	
Burner:	300 mm x 300 mm	Burner:	300 mm x 300 mm, 50 mm wide
Grid:	100 mm x 100 mm	Grid:	50 mm x 50 mm

Figure 8-11: Different Burner Configurations

The results from Series 4 were compared with the Base Case from Series 2.

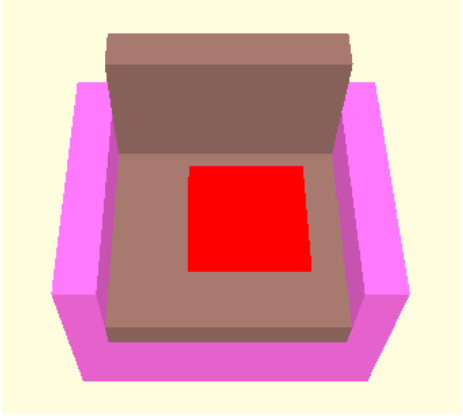
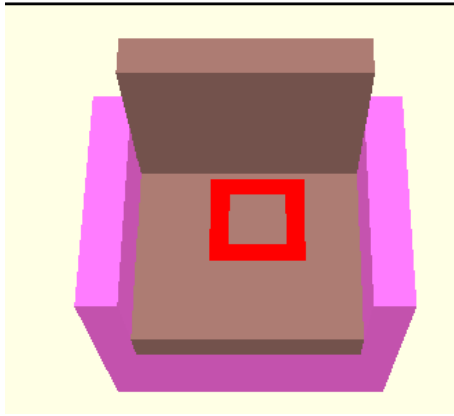

## 8.2 Modelling Results and Discussion

### 8.2.1 Surface Properties

This section discusses some of the general design decisions made with respect to the surface properties when setting up the input file for FDS. The surface properties drive the burning behaviour of the armchair, as explored in Section 8.2.3; therefore fundamental to the simulations are the initial material / surface properties of the upholstered foam cushions and the upholstery frame of the armchairs.

The surface properties were based on properties defined by Chen (2001) cone calorimeter results. Chen tested different foam / fabric combinations. The 'UPHOLSTRY' properties in the FDS database are derived from acrylic / polyurethane foam results. For the simulations the base case 'UPHOLSTRY' properties were changed to represent Chen's results for polyurethane foams / polyester fabric cone calorimeter tests. These tests used the same foams as Denize (2000), but used polyester fabric instead of polypropylene, however the properties are reasonably similar as both fabrics are thermoplastic fabrics. Chen's research found that the domestic, auditorium and aviation foam had similar properties to the Base Case properties, as shown below in Table 8-4.

Table 8-4: Upholstery Surface Properties

Foam / Fabric	Variables	
	C	T <sub>ign</sub> [°C]
Domestic / polyester	1.31	267
Auditorium / polyester	1.40	276
Aviation / polyester	1.20	299
Base case simulation	1.2	265

The SURF ID='UPHOLSTRY' as was used as the basis of all the simulations. The FDS user manual (McGrattan & Forney, 2004) comments that the upholstery properties are based on research conducted by Fleischmann & Chen (2001). As a result of this research the 'UPHOLSTRY' surface was defined as thermally thin, which assumes a constant temperature throughout the depth of the material. The armchairs have therefore been defined in this study as having thermally thin surfaces. The FDS user's manual also suggested that the BACKING = 'INSULATED' should be used in conjunction with the 'UPHOLSTRY' surface; this function prevents heat loss from the back of the material.

The fact that the armchair surfaces as thermally thin may have contributed to deviations in the simulation and experimental results. Thereby affecting the burning behaviour of the chair seat and back cushions, which were upholstered foam blocks, which in reality may not behave as a thermally thin material. To change the heat transfer characteristic of the material from thermally thin to thermally thick the thermal conductivity (KS) would need to be defined, which would require an appropriate value to be obtained from experimental data. To gain a better understanding of FDS' sensitivity to its inputs and its' ability to model upholstered furniture the furniture items should also be modelled with thermally thick material properties and compared to experimental results.

The preliminary simulations using the two methods of defining the chair frames showed that some results were independent of the method used:

- The growth rates from the simulations were similar between the two methods and were comparable to experimental results.
- The simulations had limited free burn peak HRR. In each case the peak HRR would reach a limit regardless of the amount of combustible fuel available

The two methods of representing furniture items differed with the duration of the fire, as the first method had significantly more fuel in the frame then the second method. This made comparisons with experiments difficult, as the simulated chairs frames did not physically resemble the experimental chairs. The ability to verify the results with the experimental data was the primary reason for only using the second method of defining the frame.

### **8.2.2 Series 1**

The purpose of Series 1 was to determine the capabilities of FDS to model furniture where very little detail to aid in the definition of the inputs and a limited number of tests were available to verify results.

The geometry of the 3-seater sofa geometry was based on items tested by Babrauskas, V. & Krasny (1985), the results of which were also reported by Lawson, J. R. W. et al. (1984). The 2-seater sofa geometry was modelled off experiments by Enright (1999). Figure 8-12 and Figure 8-13 below show the HRR profiles created by the FDS simulations compared to the HRR profile collected during the respective experiments for the 3-seater and 2-seater sofas.

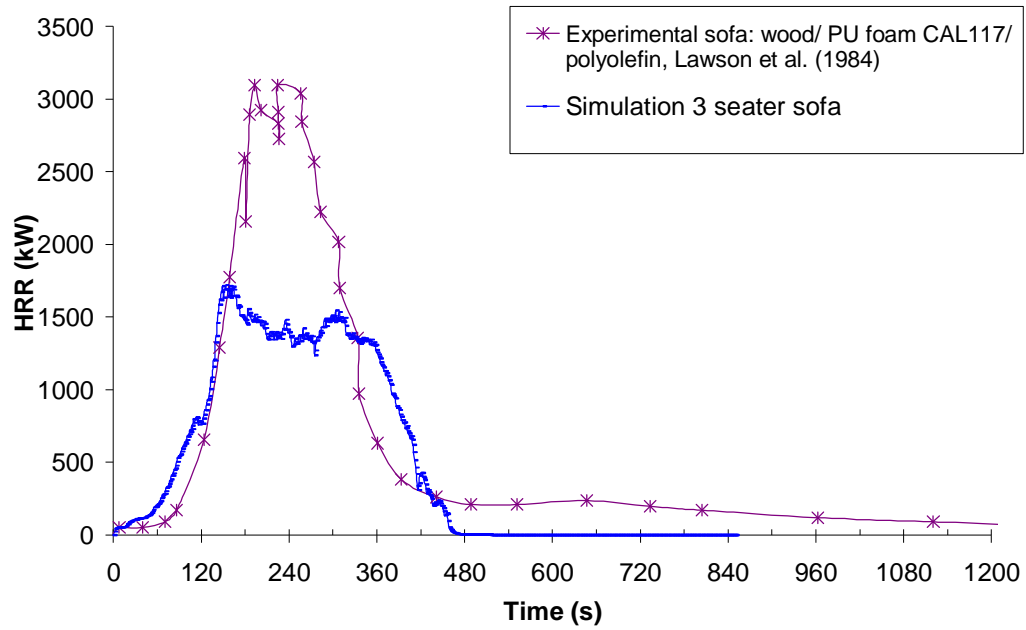

Figure 8-12: 3-Seater Sofa FDS Simulation compared with Experimental Results Lawson, J. R. W. et al. (1984)

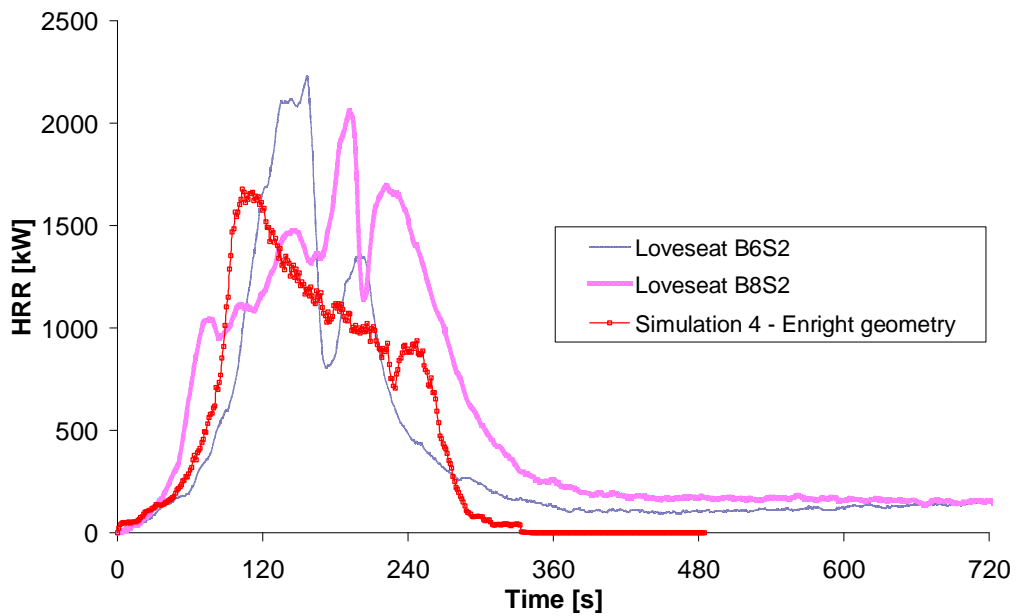

Figure 8-13: 2-Seater Sofa compared with Experimental Results Enright (1999)

In both cases the growth rates simulated in FDS were comparable to the experimental data, as were the fire durations. However both simulations failed to reach the peak HRRs achieved experimentally, at 50% and 75% of the experimental value respectively. As a result the total heat released during combustion was also reduced.

A number of reasons for the discrepancy between the experimental and FDS results have been attributed to FDS' inability to simulate some of the physical phenomena observed during experiments. For example, in full sized upholstered furniture tests pool fire burning is often observed, as discussed in many references including Sundström (1994). A pool of melted foam formed within or beneath the furniture item during the fire, which increased the surface area of fuel exposed to the fire, rapidly involving the whole furniture item. The resulting increase in burning rate often led to a higher peak HRR. There are currently no algorithms within FDS to account for the pool burning behaviour of foam and its enhancement of HRR. The discrepancy of results appears to decrease as the furniture items decrease in size; this was further demonstrated when looking at armchair simulations.

There was not enough experimental documentation or data to verify the 2-seater and 3-seater sofa simulations past this qualitative analysis. For this reason the armchair geometry was used for the remaining simulations.

Figure 8-14 shows the simulations of the two versions of the armchair.

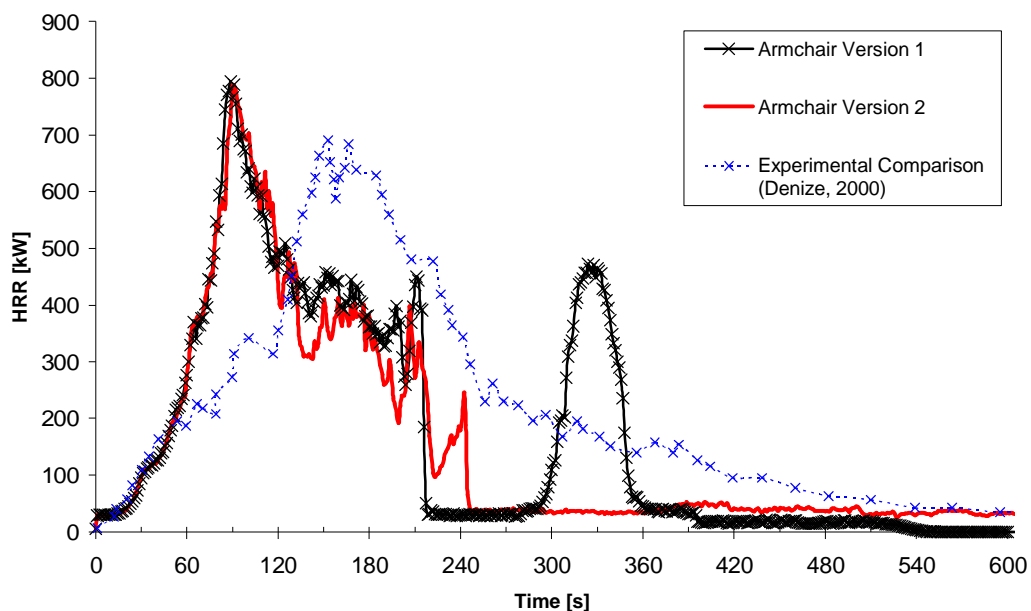

Figure 8-14: Armchair Simulations Compared with Experimental Data Denize (2000))

In the armchair simulations Version 1 developed as expected with a comparable growth stage and peak HRR, however a secondary peak appears well after the decay period where burning appears to stop.

The secondary peak does not usually occur in experimental data with furniture composed of polyurethane foam and polyester/ polyolefin type fabrics. However a second peak can occur in

upholstered furniture items containing charring fabrics such as wool or FR foams, as discussed in Chapter 3. Therefore the second peak could be attributed to smouldering of the material. However, this does not occur in the experimental results with the same materials. Therefore the second peak in the simulation occurred due to user input of the geometry as it was not expected behaviour for the specified material.

In the Version 1 armchair, the seat cushion / frame interface were defined as two layers of fabric. In Version 2, this interface was incorporated into the seat cushion and the second peak did not occur, which produced a more comparable result with the experimental data. This difference in the two versions of the armchair has been identified as a function of the way FDS calculates heat transfer through adjacent surfaces. From studying the simulations in Smokeview it appears that in Version 1 the surface of the frame did not increase in temperature until after the cushion burnt out. This resulted in a delay in the frame reaching ignition temperature (Figure 8-14).

### 8.2.3 Series 2

Each simulation was compared with the experimental results for armchairs with polyester cover fabric and various types of polyurethane foam. Figure 8-15 shows the base case free burn simulation compared to three of the chairs tested by Denize (2000).

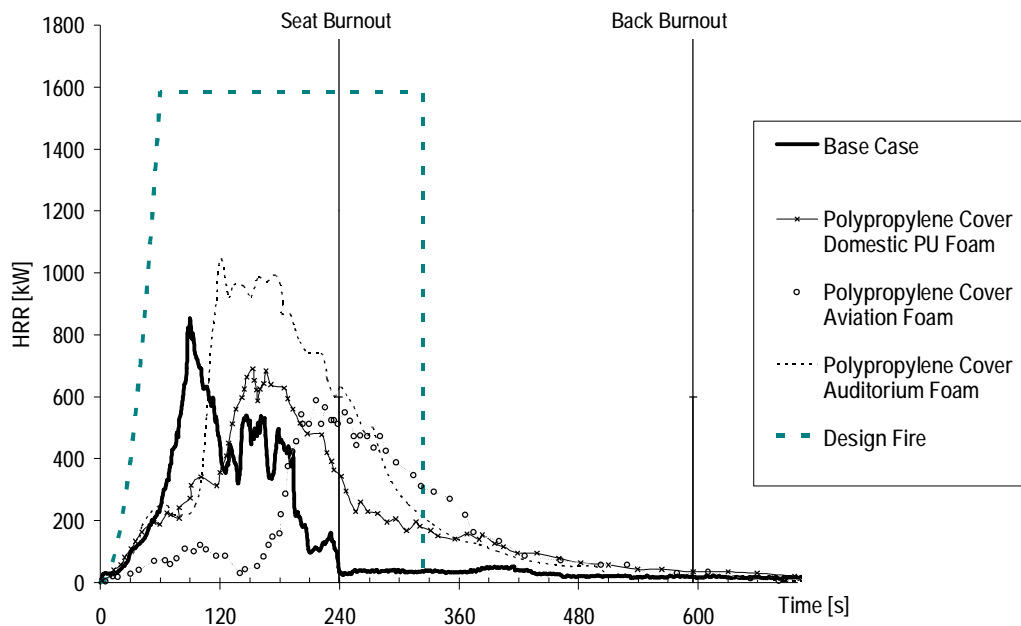

Figure 8-15: Base Case Freeburn Simulation Compared with Experimental Data  
 [CDr = 1.2 m,  $T_{\text{ignition}} = 265^{\circ}\text{C}$ , MBR = 0.03 kg/(m<sup>2</sup>.s), 0.2x0.2 m 30 kW burner]

The Base Case FDS simulation gave an HRR profile, which was the most comparable with the experimental chair, constructed of polypropylene fabric and domestic foam. This was to be expected due to the material properties for the simulation chair having been derived from experimental data for those materials. The fit would be better if the simulation curve was shifted so that the periods of rapid growth from both curves were in-line. The growth rate was comparable to the experimental data and the peak HRR was approximately the average of the three chairs.

The Base Case HRR profile and the aviation foam chair were the most dissimilar. One of the attributes of aviation foam is that it is designed to be ignition resistant, however this does not affect the comparison of results as the initial heat source was big enough in both the simulations and the experimental tests to overcome those effects. Aviation foam also tends to be significantly denser resulting in a higher peak heat release rate.

The Total Heat Released (THR) was also compared with the experimental results, Table 8-5.

Table 8-5: Total Heat Released of Base Case compared with Experimental Results

	Total Energy [MJ]
Base Case Simulation	92.8
Experimental: Polypropylene Fabric /	
Domestic Foam	127
FR Domestic Foam	144
Auditorium Foam 1	161
Aviation Foam	109
Auditorium Foam 2	188
Design Fires	
95 <sup>th</sup> percentile	379
98 <sup>th</sup> percentile	450

The THR from the simulation base case was significantly less than the chairs in the experiments and incomparable to the values calculated for the design fires. This indicated that the combustible mass was insufficient in the simulations or that the fire self extinguished before all the combustible material was used. The latter was the mostly likely cause for the discrepancy and was illustrated by the fact that the back cushion did not burn away, as was observed using Smokeview.

Another reason for the discrepancy in total heat released was possibly the values defined in the reaction properties for heat of combustion and heat of vaporisation, these variables were not changed in the

simulations. The other variables were taken from cone calorimeter tests for a similar combination of materials and further experimental study is required to realistically change these variables.

Table 8-6 summarises the burning characteristics of the armchairs in the series 2 simulations. The variables changed from the Base Case were the  $C\Delta p$ , ignition temperature and the maximum burning rate, which increased and decreased by a nominal values stated in section 8.1.3.

Table 8-6: Summary of Series 2 Simulations

Simulation	Peak HRR [kW]	Time [s]	THR [MJ]	Approximate Time of Burnout [s]		Variables		
				Seat	Back	C	T <sub>ign</sub> [°C]	MBR
Base Case	853	90	92.8	239	595	1.2	265	0.03
Case 2	741	104	93.0	248	613	1.44	265	0.03
Case 3	826	79	95.2	225	480	0.96	265	0.03
Case 4	839	73	103.9	221	315	1.2	240	0.03
Case 5	657	130	87.0	270	N/A	1.2	290	0.03
Case 6	862	90	92.9	241	624	1.2	265	0.06
Case 7	485	94	93.5	308	613	1.2	265	0.015

#### Changing the $C\Delta p$ :

Increasing and decreasing the  $C\Delta p$  ( $\pm 20\%$  Base Case) increased the THR slightly and lowered the peak HRR. Increasing the  $C\Delta p$  (to 1.44 m) lowered the peak HRR appreciably and increased the time until burnout. Decreasing the  $C\Delta p$  (to 0.96 m) decreased the time to reach peak HRR.

#### Changing the Ignition Temperature:

Decreasing the ignition temperature ( $-10\%$  Base Case to 240°C) increased the burning rate, which decreased the time to reach peak HRR and increased the THR. Increasing the ignition temperature ( $+10\%$  Base Case to 290°C) had, as expected the opposite effect.

#### Changing the Maximum Burning Rate:

Increasing the maximum burning rate (100% of the Base Case, 0.06 kg/m<sup>2</sup>/s) increased the peak HRR the most of all the variables, and decreasing the maximum burning rate (50% of the Base Case, 0.015 kg/m<sup>2</sup>/s) decreased the peak HRR the most. However, the other variables (time to peak or THR) did not change appreciably; perhaps the most significant was the THR. This indicates that the same amount of combustible fuel was consumed, only over a longer period of time.

The data sets collected in the FDS simulations were compared with information from the experimental results taken from Denize (2000), as seen in Table 8-7.

Table 8-7: Peak HRR - Simulation Comparison to Experimental Results

Experimental Results			Simulations Results		
	Peak HRR [kW]	Time [s]		Peak HRR [kW]	Time [s]
95 <sup>th</sup> Percentile	1483	90	Base Case	853	90
98 <sup>th</sup> Percentile	1586	60	Case 2	741	104
Domestic foam	690	153	Case 3	826	79
FR Domestic foam	838	147	Case 4	839	73
Auditorium foam 1	947	170	Case 5	657	130
Auditorium foam 2	1045	121	Case 6	862	90
Aviation foam	588	216	Case 7	485	94

The auditorium foam armchairs had higher peak HRR than those achieved in the simulations however the other types of foam had comparable HRRs. The time to peak HRR in the experimental armchairs was noticeably higher than in the simulations. Again this may have been due to the physics in FDS compared to 'real-life'. In experimental burns there is a certain amount of variability in the way an item will burn, this can be due to differences in, for example:

- The burner location
- The way the flame impinges on the item
- Slight difference in the fabric, foam or construction

There may also be a slight difference in the growth of the burner HRR/ temperature in the model compared to the experiments, which would also contribute to the difference.

Figure 8-16a) – g) are the graphical results of the Base Case through to Case 7 compared with the experimental results.



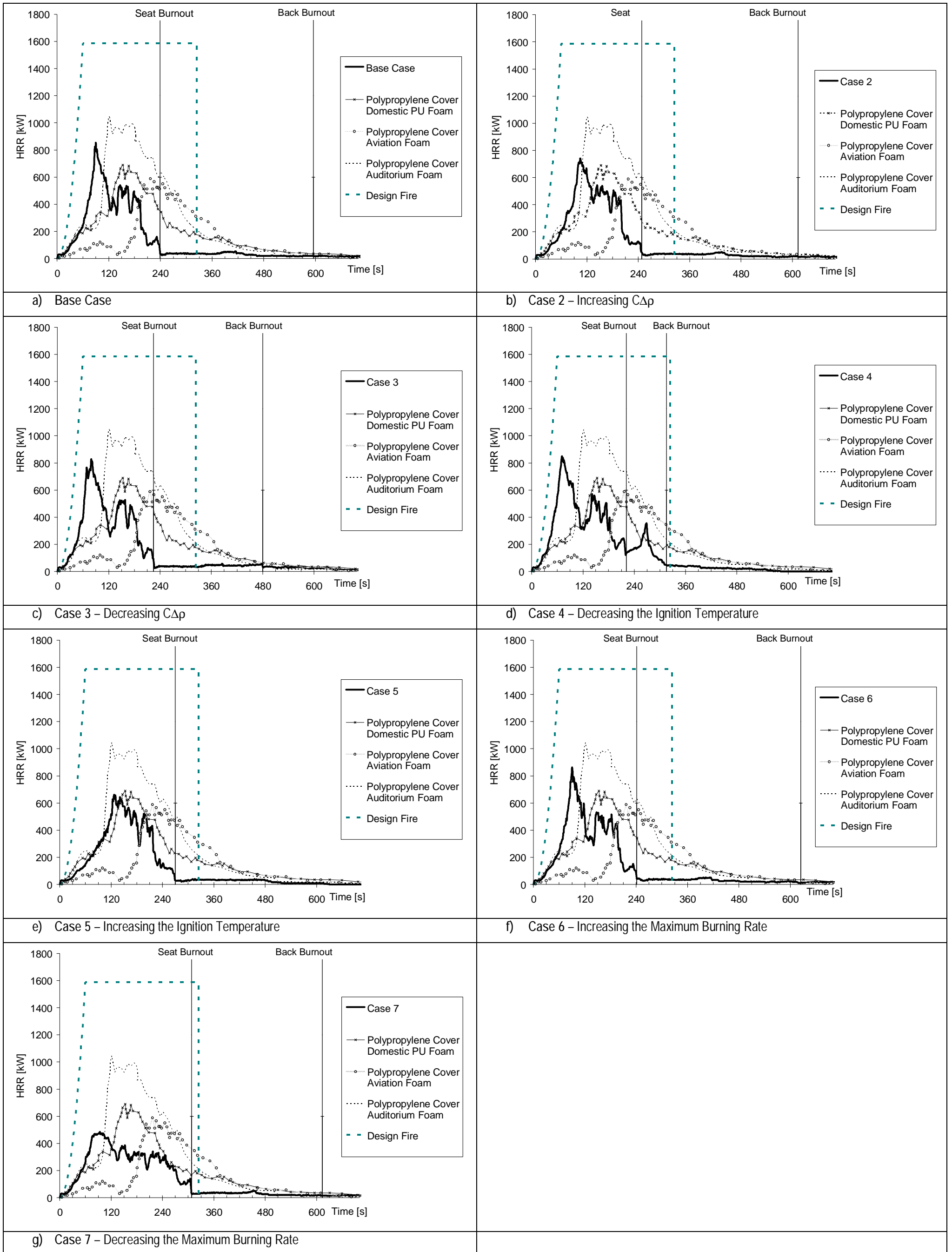

Figure 8-16: HRR Profiles of all the Freeburn Armchair Simulation Compared to Experimental Results

Case 5 had the best fit to the experimental chair with domestic foam, suggesting an increased ignition temperature may be more appropriate when modelling the combination of fabric and foam.

Table 8-8 shows the amount of combustible fuel available in the simulation chairs and the potential THR if all the combustible fuel was involved in the fire and Table 8-9 shows the THR from the results of the experimental chairs.

Table 8-8: Potential Fuel in Simulation Chairs

Chair Components	Combustible		Potential THR [MJ]
	Volume [m <sup>3</sup> ]	Mass [kg]	
Seat cushion	0.05	1.8	54
Back cushion	0.04	1.5	45
Cushions	0.08	3.3	99
Frame	0.02	0.84	25.2
Total	0.10	4.1	124

Table 8-9: Potential Fuel in Experimental Chairs

Experimental Chairs with Polypropylene fabric	THR from Chair in Free burn [MJ]
95 <sup>th</sup> Percentile	379
98 <sup>th</sup> Percentile	450
Domestic foam	127
FR Domestic foam	144
Auditorium foam 1	161
Auditorium foam 2	109
Aviation foam	188

Most of the combustible fuel was used in the experimental cases, as can be seen in photos of the tests Denize (2000). Table 8-8 and Table 8-9 show that the potential THR in the simulation chairs was comparable to the actual THR in the domestic foam chair in the experimental set of chairs. The burning mechanisms in the FDS simulation did not allow all the combustible materials to be consumed, notably the upholstery in the frame and the frame, which may account for the discrepancy between the simulation results and the experimental results.

### 8.2.4 Series 3

Series 3 compared the ISO room simulations to the free burn simulations. Below is a comparison of the Base Cases (Figure 8-17).

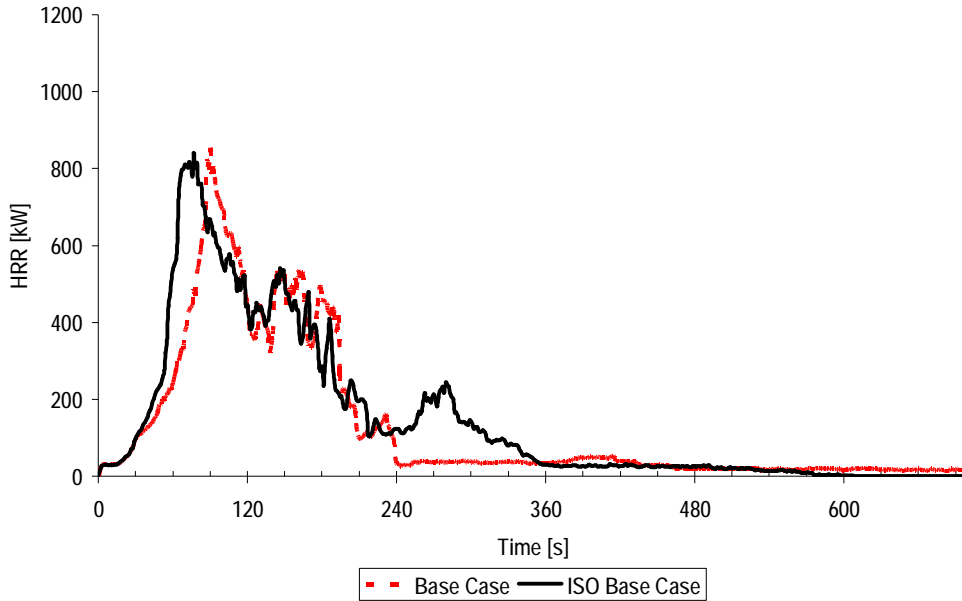

Figure 8-17: Comparison between the Base case and the ISO room base case

As Figure 8-17 shows the ISO room simulation has the faster growth rate and longer fire duration compared to the free burn case. This indicates that FDS does incorporate some compartment effects into the ISO room simulations, with respect to the growth rate and the increased THR. The increased duration and THR implies that more combustible fuel was consumed and this may have been due to radiation feedback and therefore an increased upper layer temperature.

There was no increase in the peak HRR, which was constrained either by the maximum burning rate or the physics of FDS, which restricts the surface area of the exposed fuel by not incorporating the pool burning effect.

Table 8-10 below summarizes the simulation results for the Base Case through to Case 7 in the ISO room compared to the free burn simulations. In all cases the time to peak HRR decreased, between 14% and 39%.

The peak HRR results fluctuated a lot more between the different cases. There were cases where there was minimal change (small increases and decreases in peak HRR), and in Case 5 there was a significant increase of 23%.

Table 8-10: ISO Room Simulation compared with Free Burn Simulation

ISO Room Simulation	Peak HRR [kW]	Time [s]	Approximate Time of Burnout [s]		Freeburn Simulation			
			Seat	Back	Peak HRR [kW]	Time [s]	Approximate Time of Burnout [s]	
							Seat	Back
ISO Base Case	840	77	217	312	853	90	239	595
ISO Case 2	828	84	230	553	741	104	248	613
ISO Case 3	869	65	202	301	826	79	225	480
ISO Case 4	857	62	210	354	839	73	221	315
ISO Case 5	809	80	238	N/A	657	130	270	N/A
ISO Case 6	858	74	224	N/A	862	90	241	624
ISO Case 7	480	78	301	498	485	94	308	613

None of the peak HRRs exceeded 870 kW, indicating that there may be a limit imposed on the HRR by one or a combination of the following: the physics in FDS, the geometry of the armchair, or the material properties of the upholstery cushions and frames.

Again Case 7 had the most limited peak HRR. No increase in time to peak HRR and an insignificant change in peak HRR was observed when simulated in the ISO room. In this case lowering the maximum burning rate meant compartment effects had no effect on the model.

Below in Table 8-11 the THR in the free-burn model is compared with the THR in the ISO room model for the Base Case and Case 2 to Case 7.

Table 8-11: Comparison of Total Heat Released, Free burn simulation compared with ISO room simulation

Freeburn	Total Energy Released [MJ]	ISO Room	Total Energy Released [MJ]
Base Case	92.8	ISO Base Case	104.1
Case 2	93.0	ISO Case 2	94.2
Case 3	95.2	ISO Case 3	96.4
Case 4	103.9	ISO Case 4	95.9
Case 5	87.0	ISO Case 5	87.6
Case 6	92.9	ISO Case 6	87.4
Case 7	93.5	ISO Case 7	96.0

As the results show, the cases considered here give no consistent pattern regarding the THR. There are noticeable increases and decreases in a number of the cases and insignificant changes in others. There was no relation between changes in the THR and the peak HRR of the different cases or in the variations in material properties.

It was possible that the THR may have had a general trend of increasing when in the ISO room simulations compared to the free burn simulations. This was because the creation of a hotter upper layer, may have preheated the upholstery fuel allowing more combustible material to burn before the fire extinguishes. Increases in combustible mass consumed in room burns compared to free burns has been observed in many experimental results, particularly where items had higher ignition resistance. The hot gases preheat the upholstery creating combustible gases, which aid further combustion, overcoming the ignition resistance.

Figure 8-18 a) – g) are graphical representations comparing the ISO room simulations with the free burn simulations.

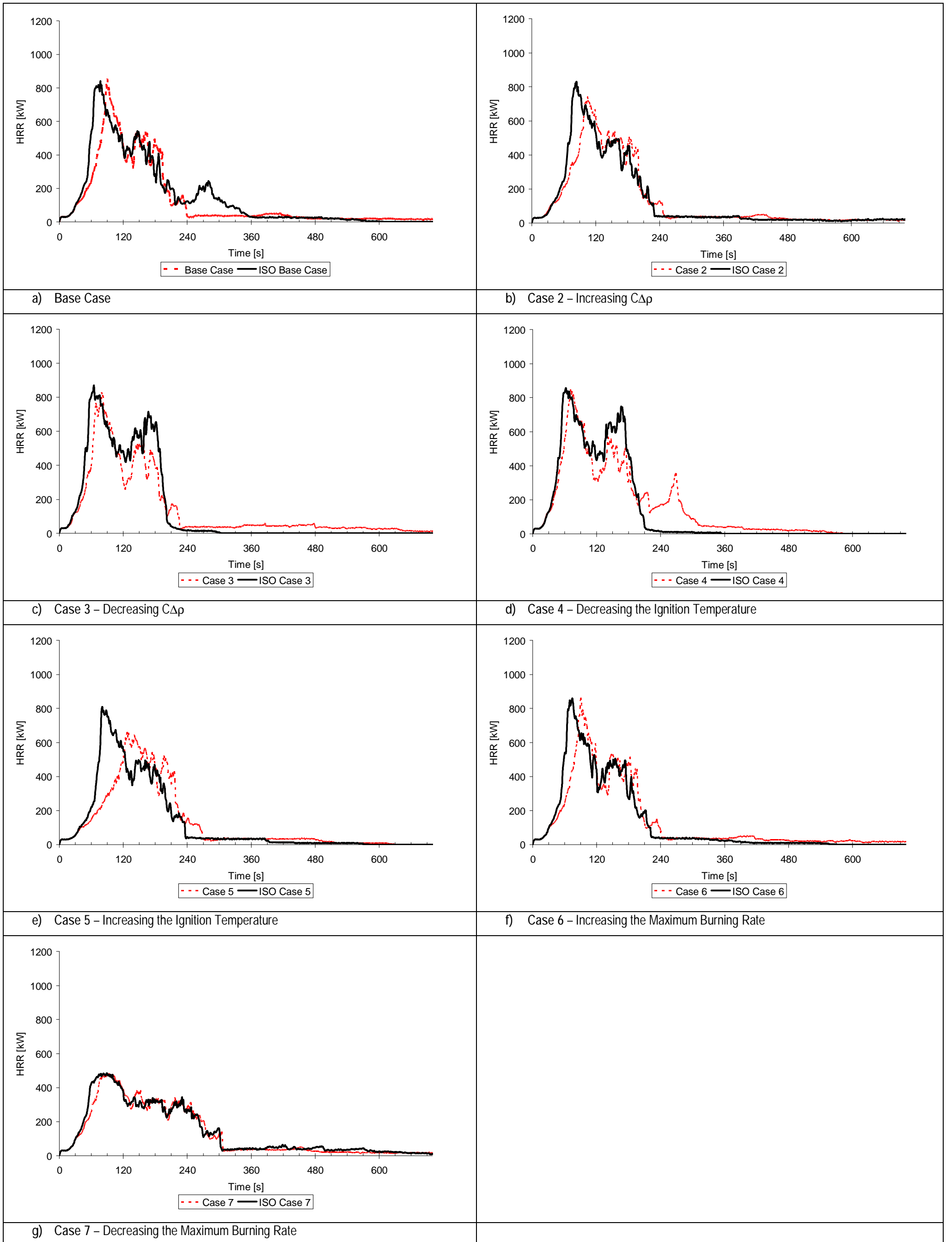

Figure 8-18: HRR Profiles of all the ISO Room Armchair Simulations Compared to Free-burn Armchair Simulations

**Changing the CDr:**

Increasing  $C_{\Delta\rho}$  (+ 20% Base Case to 1.44 m) noticeably increased the growth rate compared to the corresponding free burn simulation. Decreasing the  $C_{\Delta\rho}$  (- 20% Base Case to 0.96 m) did not appreciably change the growth rate in the ISO room fire compared to the free burn fire.

**Changing the Ignition Temperature:**

Decreasing the ignition temperature (- 10% Base Case to 240°C) did not appreciably change the growth rate or the peak HRR compared to the free burn simulations. Increasing the ignition temperature (+ 10% Base Case to 290°C) gave the most significant changes in terms of increased growth rate and increased peak HRR.

**Changing the Maximum Burning Rate:**

Increasing the maximum burning rate (100% of the Base Case to 0.06 kg/m<sup>2</sup>/s) did not increase the peak HRR but did have an effect in the ISO room simulations, showing a moderate increase in the growth rate. Decreasing the maximum burning rate (50% of the Base Case 0.015 kg/m<sup>2</sup>/s) had no effect on the HRR profile when the armchair fire was simulated in free burn and in the ISO room.

In summary Figure 8-18 e) Case 5, with higher ignition temperature (290°C), had the HRR profile, which matched the base comparison experimental chair (domestic PU foam) the most in free burn conditions. Case 5 also illustrates the compartment effects in FDS the best, with a noticeable increase in peak HRR and increase in growth rate. The Base case, Case 2 and Case 6 also had noticeable increases in growth rate; however the other variations in material properties did not comprehensively show any compartment effects.

The data collected in the ISO room FDS simulations were then compared with experimental results taken from Girgis (2000), as shown in Figure 8-19 a) – g). It has been noticed after completion of the simulations that the location of the armchairs' in the simulations differed from those in the experiments conducted by Girgis (2000). The simulations had the chairs in the middle of the room whereas the experiments had the chairs in the back corner. Though not directly comparable the ISO room simulations clearly show the limitations of FDS when modelling compartment effects.

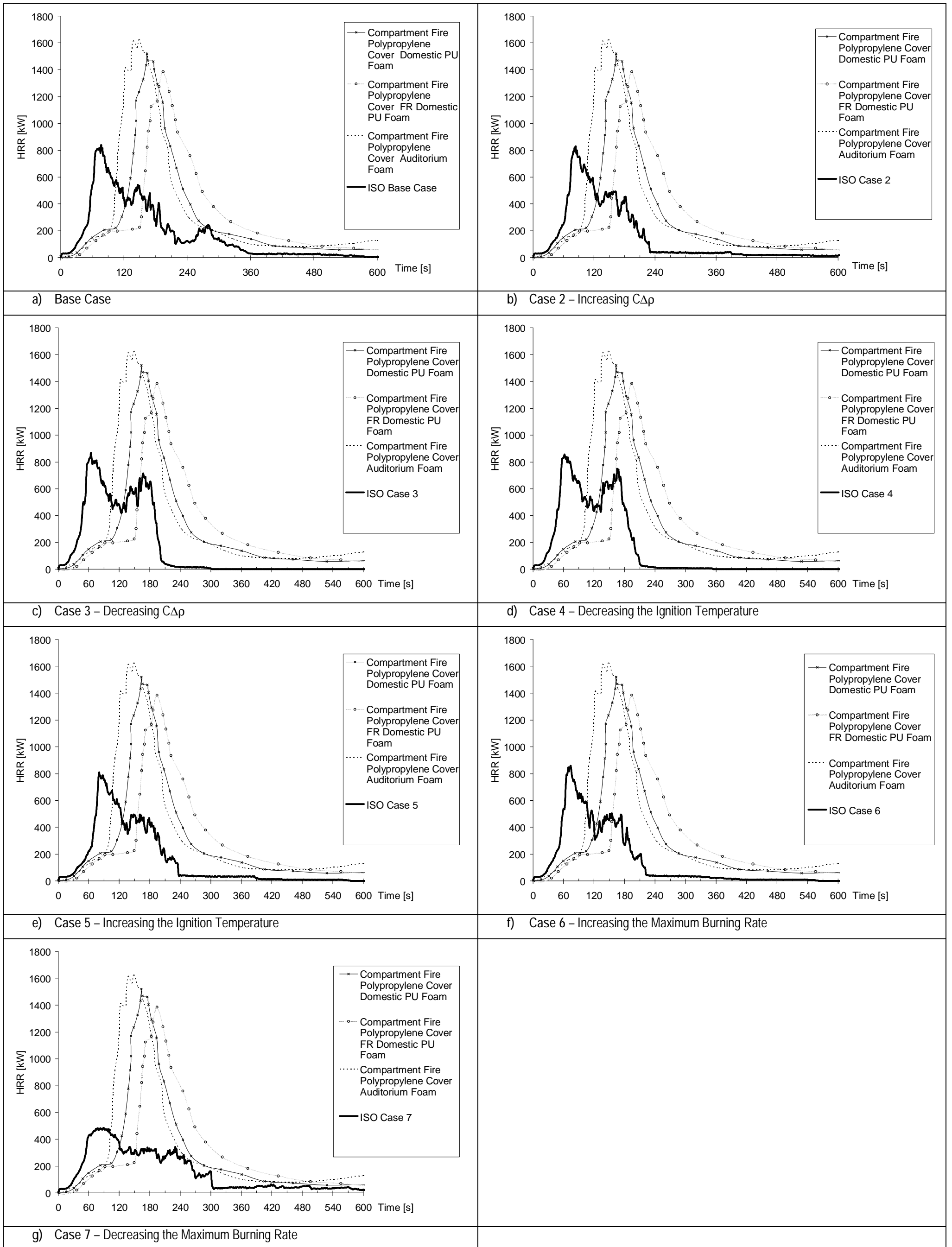

Figure 8-19:- HRR Profiles for ISO Room Armchair Simulations Compared with ISO Room Experimental Results



As shown above the experimental results show a significantly higher peak HRR, THR and fire duration. However, the growth rates, when the  $t = 0$  point is shifted have a reasonably good fit. The FDS model was shown to be greatly limited in terms of modelling even a moderate increase in peak HRR.

A reason for the significant difference in peak HRR and THR is evident when comparing the THR of the free burn and the ISO room experiments (Table 8-12).

Table 8-12: THR in Free burn Experiments compared to the THR in ISO Room Experiments

Experimental Chairs with Polypropylene fabric	THR from Chair in Free burn [MJ]	ISO Room THR [MJ]	Simulation Chairs	Calculated THR [MJ]
95 <sup>th</sup> Percentile	379	572	ISO Base Case	104.1
98 <sup>th</sup> Percentile	450	679	ISO Case 2	94.2
Domestic foam	127	212	ISO Case 3	96.4
FR Domestic foam	144	196	ISO Case 4	95.9
Auditorium foam 1	161	231	ISO Case 5	87.6
Auditorium foam 2	109	247	ISO Case 6	87.4
Aviation foam	188	253	ISO Case 7	96.0

The THR in the ISO room experiments produced around 100 MJ of energy, however in both experiments the chairs were essentially burnt out. The difference in the experimental results can be equated to the paper lining burning off the gypsum board walls in the ISO room tests. This highlights another difficulty in comparing ISO room experiments with free burn experiments, introduction of new fuel sources, which may not be explicitly defined.

The comparison of the ISO room experiments and the ISO room simulations is still valuable as it shows the importance of considering the surface of the wall linings and how to incorporate them into the design fire. The walls of the ISO room in the simulations were defined as gypsum board and therefore had the same heat transfer and ignition qualities as the experimental rooms. However, the properties in the FDS database do not account for the paper layer on the gypsum board, which increased the fuel load in the experiments. This raises issues, which warrant further research such as whether fuels should be accounted for in the burning objects or if there is a way to integrate it to the wall surface without having a severely detrimental effect on the computational time.

### 8.2.5 Series 4

Series 4 was a small qualitative sensitivity analysis of the Base Case simulation, specifically looking at the grid size and changing the geometry of the burner. The results are summarised in Table 8-13.

Table 8-13: Series 4 Results

Simulation	Grid Size (mm x mm)	Burner Dimensions (mm x mm)	Peak HRR [kW]	Time [s]	THR [MJ]	Approximate Time of Burnout [s]	
						Seat	Back
Base Case	100 x 100	200 x 200	853	90	92.8	239	595
Case 8a	80 x 80	200 x 200	934	77	102	217	191
Case 8b	60 x 60	200 x 200	691	65	127	278	384
Case 8c	50 x 50	200 x 200	702	62	157	274	309
Case 8d	40 x 40	200 x 200	716	52	140	289	N/A
Case 9	100 x 100	300 x 300	782	52	112	343	301
Case 10	50 x 50	square ring burner	739	54	154	218	278

All the cases showed significant differences to the Base Case, showing that the Base Case chosen is not only sensitive to the material property inputs but also very sensitive to geometric inputs in terms of specific burner geometry and grid size.

A general trend in the Series 4 cases showed a decrease in peak HRR and time to peak HRR, but an increase in THR compared to the base case simulation. The seat burnt out slower than in the Base Case but the backs burnt out significantly earlier.

As with Series 1 the Series 4 results have been compared with experimental results from Denize (2000) (Table 8-14).

Table 8-14: Series 4 THR results comparison with experimental results

Experimental Chairs with Polypropylene fabric	Potential THR [MJ]	Simulated Chairs	Calculated THR [MJ]
95 <sup>th</sup> Percentile	379	Base Case 100 mm grid	92.8
98 <sup>th</sup> Percentile	450	Case 8a 80 mm grid	101.7
Domestic foam	127	Case 8b 60 mm grid	126.5
FR Domestic foam	144	Case 8c 50 mm grid	156.9
Auditorium foam 1	161	Case 8d 40 mm grid	139.5
Auditorium foam 2	109	Case 9	111.9
Aviation foam	188	Case 10	153.6

Case 8 and Case 10, which have the smaller grid sizes, compare better with the experimental results in terms of THR compared with the Base Case. Case 9 also has a higher THR though it still falls into the range given the experimental results.

The HRR profiles of the Series 4 simulations are shown graphically in Figure 8-20 to Figure 8-24. The burning behaviour varied significantly between the Base Case in Series 2 and Series 3 simulations. However, it was expected that the Series 4 simulations would have similar results to the Base Case. Each case has been discussed in more detail below.

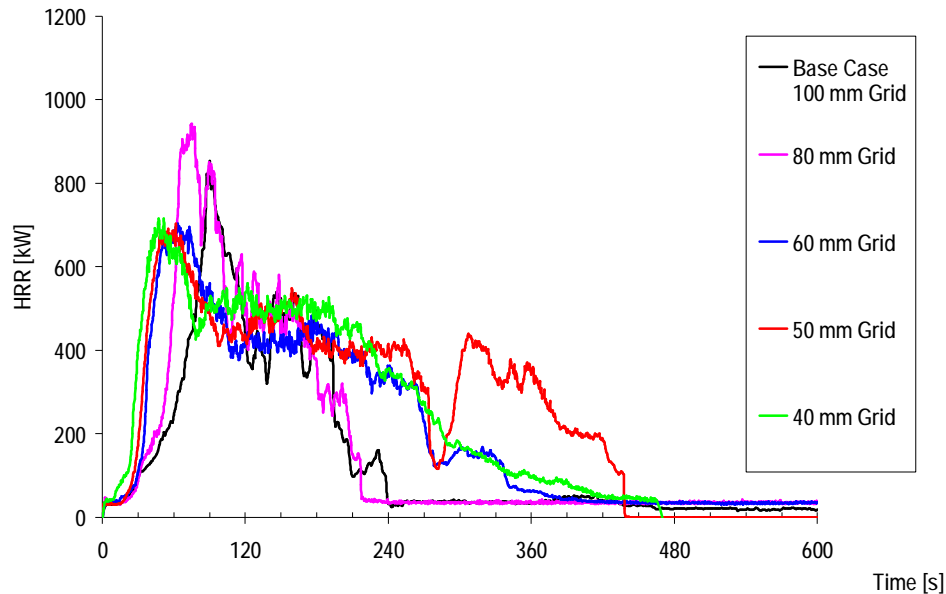

Figure 8-20: Case 8 (Smaller Grid Sizes) – Free Burn HRR Profile

For the Case 8 group of simulations the grid size was systematically reduced. Unfortunately the simulations show in Figure 8-20 that the HRR profile changes with even a small change in grid size. This could indicate a sensitivity of the model or be related to the subtle change in location of the burner to the chair.

The time to peak HRR decreased with the decrease in grid size. The peak HRR was highest for the 80 mm grid, the grid sizes smaller than 80 mm had lower peak HRRs, which were consistent with each other. The similarity between the 60 mm grid and the 40 mm grid would normally indicate the simulation has become independent of grid size. However, there was an anomaly in the change in HRR profile is the 50 mm grid which has a drop in HRR and then a second peak which does not appear in the other Case 8 simulations. There was also no consistency with regards to seat and back burn out times in the Case 8 simulations, if the simulations were independent of grid size it would be expected that the burnout times would be very similar to each other.

In terms of modelling the ‘real armchairs’ accurately the best fits were the 100 mm grid and the 80 mm grid, as show below in Figure 8-21.

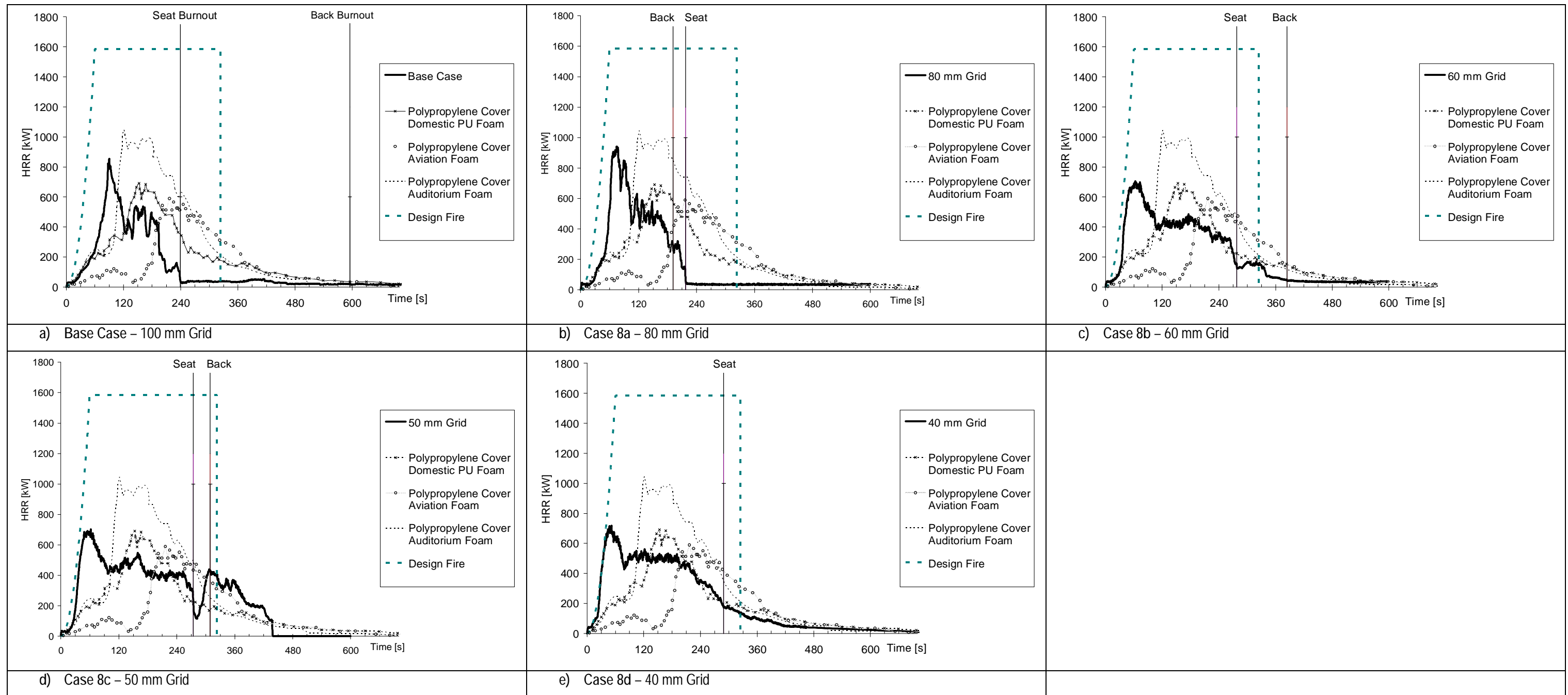

Figure 8-21:- HRR Profiles for Case 8 Armchair Simulations – Different Grid Sizes, Compared with Free burn Experimental Results

Case 9 had a larger burner area with the same heat output and the same grid size as the Base Case, the HRR profile is in Figure 8-22.

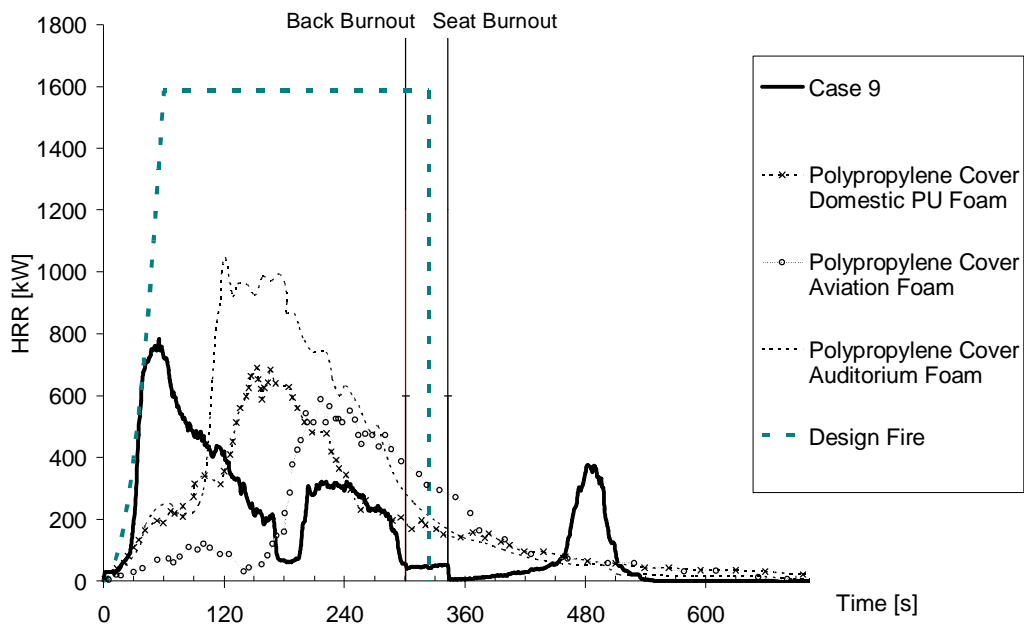

Figure 8-22: Case 9 (300 mm square burner) – Free Burn HRR Profile

Out of all the simulations the HRR profile of Case 9 varied the most from the Base Case, specifically:

- There are three peaks in HRR, with the last peak after an appreciable length of time after the seat and back cushions burn out.
- In this simulation the chair back burnt out before the chair seat, which did not occur in any of the other simulations.

The chair back may have burnt out before the seat because the burner was physically larger. It did not centre on the chair seat because of the grid size so was positioned closer to back corner and covered a greater area of the chair seat compared to the other simulations. This would create a more even heating of the chair, aiding the flame spread and igniting the seat back more quickly.

The unusual peak at the end of the simulation occurred in Series 1 and was caused by the definition of the armchair surfaces. It is unclear whether there is a similar explanation for the occurrence in the Case 9 armchair as it was defined the same as the Series 2 and Series 3 armchairs, where this behaviour did not occur. The second delayed peak in HRR may be caused by the heat of vaporisation model in FDS, with residual heat from the main fire re-igniting some of the upholstery as defined on the chair frame. This second peak requires further research.

Case 10 was the more complex burner geometry, the square ring burner, and a 50 mm x 50 mm grid. The ring burner simulated the actual burner used in the experiments the most accurately; the simulation was compared to the experimental data as shown in Figure 8-23.

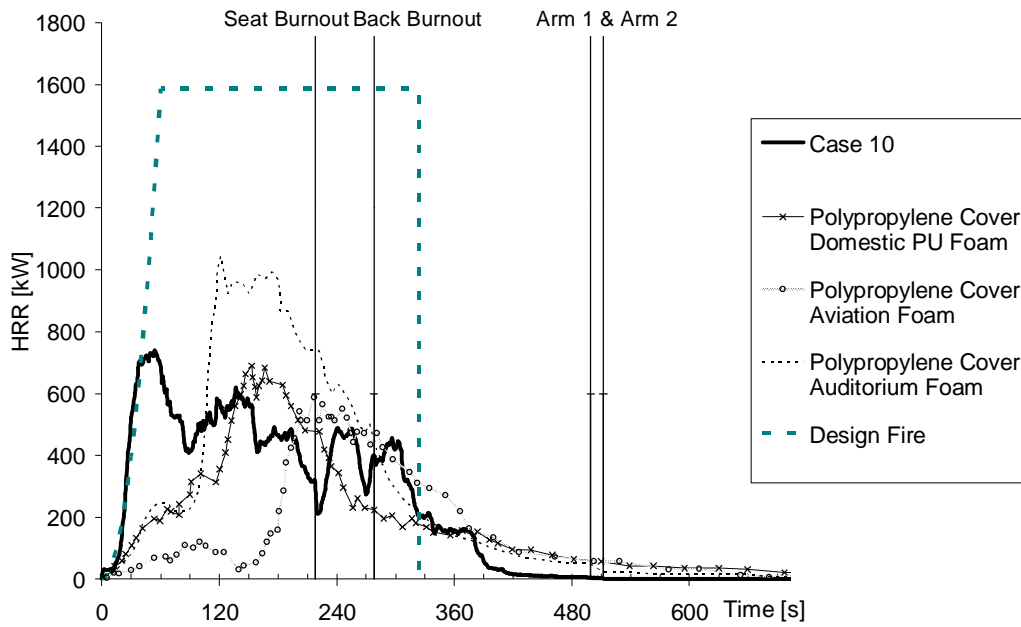

Figure 8-23: Case 10 (smaller grid & square ring burner) – Free Burn HRR profile

Case 10 had a square ring burner and a smaller grid than the Base Case. The 50 mm grid was chosen because the grid size fit the armchair dimensions. Therefore the Case 10 simulation has been compared to the Case 8 simulations with the smaller grid sizes (Figure 8-24)

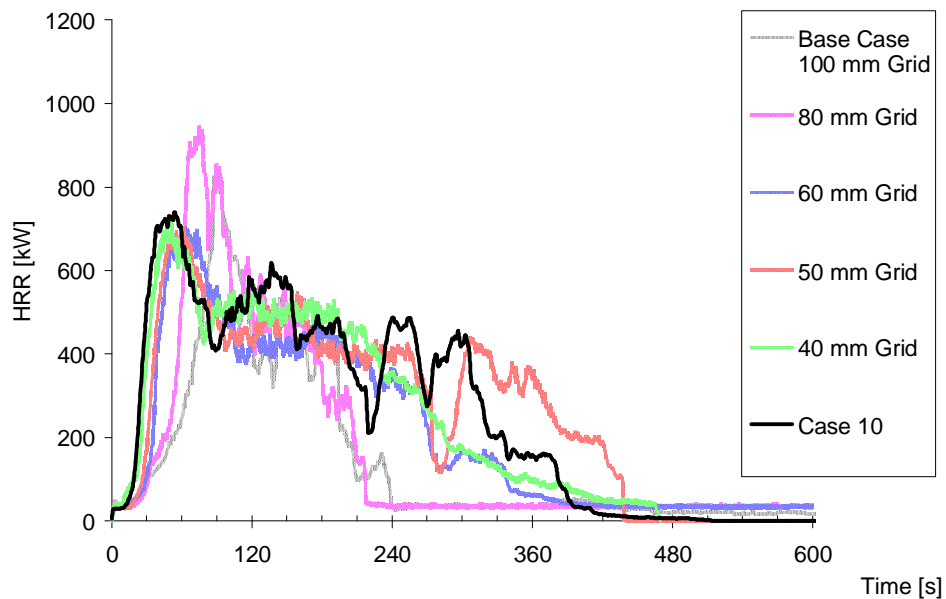

Figure 8-24: Case 10 (square ring burner), Compared with Case 8 Simulation Results

As there are two variables in Case 10 being changed from the Base Case it was more difficult to determine what effect was dominant, the smaller grid size or the burner geometry. However as Figure 8-23 shows the Case 10 simulation had a similar HRR profile to the Case 8 grid sizes 60mm, 50 mm and 40 mm, which had a lower peak HRR compared to the Base Case and a longer period of relatively steady state burning.

A notable difference was that the arms of the chair frame burnt out in the Case 10 simulation. This can be attributed to the shape of the burner, which changed the flame-spread characteristics across the surface of the chair. Comparing the Case 8 and Case 10 simulations, the square ring burner produced a comparable peak HRR and growth rate and earlier burn out of the chair seat and back.

### **8.3 Summary**

Due to the complex nature of the fire behaviour of upholstered furniture it was difficult to model the furniture accurately. By imposing a number of constraints and identifying the limitations of model it was hoped that an upholstered furniture fire could be modelled accurately enough to begin developing design fires for use in FDS. Below is a summary of each series of FDS simulations and the conclusions that were reached.

#### **8.3.1 Series 1**

Series 1 modelled different furniture sizes and methods of defining furniture items within FDS. As the furniture item became larger, armchair to 2-seater to 3-seater sofa, with higher fuel loads and greater dimensions, FDS was limited in its ability to model the peak HRR. This was attributed to the FDS model being unable to model the pool fire formation characterised in upholstered furniture fires described in observations made during experimental tests, e.g. Sundström (1994).

Though a 3-seater sofa has the largest fuel load and most clearly demonstrated some of the limitations of FDS when simulated it was not used in the other series. This was because 3-seater and 2-seater sofas there was limited experimental data and details of experimental process and the items tested that the most appropriate item was the armchair. Because there was sufficient data from armchairs tested it was possible to change material properties in FDS and compare HRR profiles with experimental data.

#### **8.3.2 Series 2**

FDS' ability to model variations of materials used in experiments was assessed by varying specific material properties. Series 2 altered the material properties of the fuel defined in FDS around a base set of properties derived from cone calorimeter tests (Chen, 2001). The FDS simulations were compared to armchairs with polypropylene cover fabrics with either, standard PU foam, auditorium PU foam and

aviation PU foam. The foams increase in density and ignition resistance. The FDS simulations gave comparable HRR curves to the experimental results. The growth rate was the most similar characteristic when compared to the experimental results, and the peak HRR was about the average of the three experimental curves it was compared to. The simulations did not model any incipient burning; due to the large burner size chosen to overcome any smouldering behaviour in the simulations. The base case was comparable to the experiments giving an average between the three experimental cases in terms of peak HRR, time to peak HRR, duration of the fire.

The material properties which decreased the combustibility of the surface materials were, increasing the  $C\Delta\rho$ , increasing the ignition temperature and decreasing the maximum burning rate had noticeable effects on the HRR profile compared to the base case, decreasing the severity of the fire, in terms of peak HRR and/ or time to peak HRR.

Altering the material properties to increase combustibility, that is, decreasing the  $C\Delta\rho$ , decreasing the ignition temperature and increasing the maximum burning rate (MBR), did not alter the HRR profile significantly.

Increasing the ignition temperature from the base values used gave the best fit to the domestic polyurethane foam chair and the base case gave a reasonable average between all the chairs tested. In general the growth rate of the simulations was faster than in the experiments unless the  $t = 0$  point was moved so points of rapid growth matched up.

The peak HRRs achieved in these simulations was about the average of the experimental results. However, none of the simulations reached the highest experimental peak HRR of 1 MW.

The potential Total Heat Released (THR) calculated from the amount of combustible fuel modelled in the simulations was equitable to the THR in the experiments; however the THR in the simulations was significantly less. The fires in the experiments consumed most of the available fuel, whereas it appeared the fires burnt out before all the fuel was consumed in the simulations.

### **8.3.3 Series 3**

Series 3 simulated chairs burning inside an ISO room. The chairs had different material properties, the same chairs as Series 2.

The Base Case and changing the material properties by increasing the  $C\Delta\rho$ , increasing the ignition temperature and increasing the maximum burning rate showed noticeable increases in growth rate



compared to the Series 2 simulations. Decreasing the  $C\Delta\rho$ , decreasing the ignition temperature and increasing the maximum burning rate had a negligible effect on HRR profile significantly.

The Total Heat Released (THR) in the ISO room simulations did not appear to follow any trends; there were cases with slight increases, negligible changes and slight decreases in THR compared to the Series 2 simulations.

The ISO room simulations were compared to ISO room experimental results with equivalent chairs from the experimental results used in Series 2. The growth rates were comparable when the  $t = 0$  point was moved. However the ISO experiments had considerably higher peak HRRs compared to the free burn experiments, for example 1 MW increased to 1.8 MW. This was not replicated in the simulations. This comparison is limited because in the ISO room experiments the Gib board lining the room had paper lining, which contributed to the fuel load. The extra fuel was not accounted for in the simulations, however an increase in HRR of some sort would still be expected and there were negligible increases in the simulations.

#### **8.3.4 Series 4**

Series 4 was a small qualitative sensitivity analysis. It was determined that the simulations in the preceding series were not independent of grid size. The grid size was systematically reduced from 100 mm to 80 mm, 60 mm, 50 mm and 40 mm. The HRR profile changed noticeably between the 80 mm grid and 60 mm. There was also an anomaly with the HRR profile of the 50 mm simulation. The larger grid sizes (100 mm and 80 mm) did however have a better fit with the experimental data.

Two different burner geometries, with the same heat output, were also simulated in Series 4. It was found that the HRR profile of the armchair fire was also sensitive to the burner geometry.

#### **8.3.5 General**

There are subtleties in the burning behaviour of furniture items, and fires in general, which are difficult to model. For example:

- In reality furniture fires preheat the upholstered surfaces beneath them resulting in continuous burning. In FDS there was a delay when one surface was directly over another due to the preheating requirement to reach ignition temperature.
- The combustible material surfaces in FDS were modelled as thermally thin. In some cases this assumption is more accurate than defining a thermal conductivity so the surface adopts thermally thick properties. It would be advantageous to model the surfaces as thermally thick to ascertain whether the results would be more favourable.

- The FDS simulations are evidently sensitive to grid size and location and physical size of the ignition source.

The purpose of simulating the individual items in FDS was to determine whether they were modelled accurately, particularly in a compartment environment. FDS showed promise in simulating the growth rates of the experimental items. However, it had significant limitations in terms of peak HRR and the THR. More research is needed to determine how the deviations can be rectified. This could be by user input of material properties, in particular defining a thermally conductivity, or changing how the item geometry / surfaces are defined. Or it could be incorporating a pool fire effect when upholstered furniture items burn by adding it as an algorithm in FDS or a pool fire be added manually using a vent type function.

The simulations in FDS were done with the philosophy that, if the chair could be modelled accurately in the immediate vicinity of the fire, then more remote environmental conditions would also be modelled well. This approach was taken as there is considerably more data as the tests get smaller, that is, full scale building tests to multi room tests to full scale calorimeter tests (free burn / room) to reduced scale and cone calorimeter tests. There has been a lot of research to find correlations between small scale (cone and reduced scale) and full scale (room and free burn calorimeter) tests. There are only a few larger tests, and therefore limited amounts of data, as the larger the test the more costly it is.

The purpose of FDS in a design context is usually to assess the effects of a fire, remote from its location. The intent of the FDS research was to model individual items accurately, then model and verify fire spread between items and then multi-item fires, increasing the complexity. With complex scenarios modelled accurately it would be possible to simplify the scenario fires into specified HRR profiles and defined reactions. The simplified fires are then more appropriate for use in design, allowing for a coarser grid and therefore faster computational time while still give accurate design constraints / parameters.

## 9 Conclusions

### 9.1 General

This thesis looked specifically at design fires in residential buildings, as fire statistics show upholstered furniture is the main contributor to the fuel load in a large proportion of fires where fatalities occur. There were two objectives; to create a credible set of design fires, and to develop a methodology for incorporating compartment effects.

The first step to creating a credible set of design fires was to conduct a comprehensive literature review, on beds and bedding assemblies and upholstered furniture. The literature review ascertained what data was freely available and what fire characteristics were well recognised/ generally accepted. The review found there was a lot of data available, however specific details of the experiments and the amount and detail of the data varied considerably. There were a number of generally accepted characteristics as described in Chapter 5, for example:

- Upholstered furniture items often form foam pool fires
- Armchairs produce enough heat to cause a room to flashover
- The type of bedding can significantly effect (both adversely and favourably) the burning behaviour of a bedding assembly

Another literature review was also completed on compartment effects as part of the second objective, to create a methodology to incorporate compartment effects. The review found there were a number of qualitative recommendations, with results depending on a number of variables including:

- Compartment size
- Ventilation conditions
- Fuel type/ configuration

After considering the data available the project focussed on upholstered furniture items, which were divided into four categories;

- Armchairs
- 2-seater sofas
- 3-seater sofas and
- bedding assemblies

Ideally all the burning characteristics, as listed in the introduction, would have been assessed, however there was sufficient data for only the following characteristics to be studied quantitatively:

- HRR profile with respect to time (growth rate)
- Peak HRR
- Time to peak HRR
- Total Heat Released (THR)
- Maximum CO/CO<sub>2</sub> ratio

The creation of design fires and incorporation of compartment effects is detailed in the Section 9.2 Recommendations. A basic statistical analysis of experimental data was used to create recommendations for free burn design fires and factors to incorporate compartment effects into the design fires. The analysis as applied to the experimental data provided a methodology for incorporating compartment effects and the factors determined from the results was of secondary importance.

The main limitation of the results is the small sample sizes used to develop the recommendations, as the values were determined using basic statistical analysis and curve fitting of experimental data. It is expected that as the sample size increases the experimental data will show a better fit to distribution curves, thereby providing results with a greater degree of certainty.

FDS was also used as to develop a methodology for creating design fires and incorporating compartment effects. The sensitivity of the input variables (material properties) in FDS was evaluated; it was found that the results were very sensitive to the inputs. FDS was better at predicting armchair burning behaviour compared to 2-seater and 3-seater sofas. The greatest limitation was that FDS appeared to cap the HRR at a peak of approximately 1.8 MW regardless of total fuel load available. This was attributed to the complex burning behaviour of upholstered furniture items and FDS' ability to model this behaviour, in particular the pool burning behaviour that occurs with foam fires.

FDS is usually used to assess the effects of a fire, at a location remote from the fire origin. This thesis considered the first step in using FDS to create standardised design fires, this was to attempt to model individual items accurately. Future steps are to model and verify fire spread between items and then multi-item fires, increasing the simulation complexity. Once complex scenarios are modelled accurately they could be simplified into specific design fire scenarios with HRR profiles and defined reactions. The simplified fires are then more appropriate for use in design, allowing for a coarser grid and therefore faster computational time while still giving accurate design constraints / parameters.

However, the results of the FDS simulations found that it did not, at this time, have the capability of modelling the complex burning behaviour of even a single furniture item. As such, when using FDS as a design tool it is recommended that the design fire be defined in the same way as currently used in zone models. Modelling compartment effects also had limited success; FDS modelled a faster growth rate however other compartment effects were not readily identified from the simulation results.

## 9.2 Recommendations

The aim of this project was to lay the foundations for standardised design fires for residential buildings. Below is a set of preliminary recommendations for design fires for individual upholstered items based on a statistical analysis of a relatively small sample set.

### Design Fires – Free Burn

The following upholstered furniture fire characteristics; peak HRR, time to peak HRR, growth rate and Total Heat Released form the basis of the design fire. For each type of furniture item recommendations for the key fire characteristics have been defined. The recommendations for each fire characteristic represent the 98<sup>th</sup> percentile of the experimental data. From the peak HRR and the time to peak HRR recommendations a  $t^2$  growth rate can be calculated for the design fire recommendations.

Table 9-1: Design Fire – Free Burn Recommendations

Item	Peak HRR [kW]	Time to Peak HRR [s]	Total Heat Released [MJ]	Growth Rate a [kW/s <sup>2</sup> ]
Armchair	1586	60	450	0.441
2-seater sofa	2643	93	600	0.306
3-seater sofa	2933	148	980	0.134

The design fires developed from Table 9-1 are shown below in Figure 9-1 compared with  $t^2$  fires.

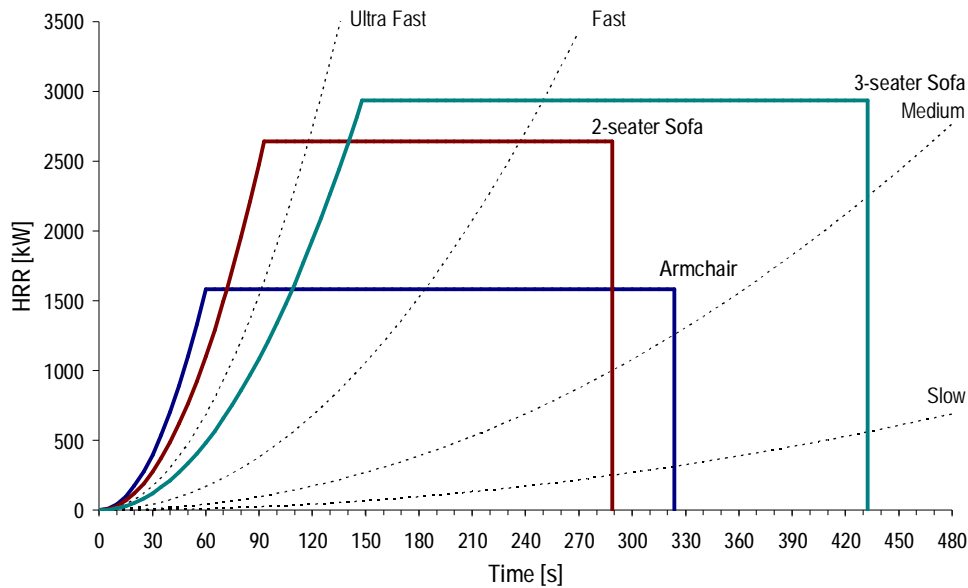

Figure 9-1: Preliminary Design Fires for Upholstered Furniture Items

It is important to note that the above recommendations do not include an incipient stage. Based on the analysis of growth rates, which considered an incipient stage, the  $t^2$  growth rate was between fast and ultra fast. More research is required to consolidate the difference between the statistical analysis of the experimental growth rates and the design fire growth rates.

Quantitative recommendations for bedding assemblies based on limited experimental data (four experiments) are:

- Peak HRR - not less than 3.85 MW
- Time to Peak HRR - not more than 305 s

Maximum CO/CO<sub>2</sub> ratio based on limited experimental data (five experiments) found the values ranged from 0.002 – 0.011 with an average ratio of 0.006. This qualitatively illustrates the CO produced in free burn situations is low, due to the favourable ventilation conditions.

### Compartment Effects

Based on the comparative study of free burn and ISO room burn tests of upholstered furniture items, the following parameter changes are recommended to incorporate compartment effects into the above design fire parameters.

Table 9-2: Design Fire – Compartment Effects Recommendations

Peak HRR	156% Increase
Time to peak HRR	- 39% Decrease
Total Heat Released	51 % Increase

The following qualitative recommendations have been made:

- The  $t^2$  growth rates should increase however should still be between fast and ultra fast.
- A compartment fire has a significantly greater CO/CO<sub>2</sub> ratio compared to a free burn fire, due to ventilation conditions/ oxygen concentration at the fire. The increase in CO needs to be considered however more research is required to quantify the increase. The limited experimental data (five experiments) showed increases between 10 and 50 times that of the free burn ratios.

A methodology was devised to use FDS to create design fires by modelling individual furniture items with the intention of extending it to typical residential building fires then creating sets of reasonable worst-case scenarios for use in design. However this phase, though promising, requires further research as detailed below.

### **9.3 Future Research**

Further research in the following areas would be advantageous in the development of standardising design fires for residential buildings.

#### **Experimental Data**

There are a number of limitations when considering the analysis of these results, the main limitations to be aware of are:

- The data sets were small, more experimental data would increase the reliability of the statistics
  - As furniture items increased in size the number of experiments decreased, i.e. there were more experiments with arm chairs than 3-seater sofas
  - There was limited data collected for some outputs such as CO/ CO<sub>2</sub> ratios and THR
- Compartment data comes from experiments where the compartment sizes were small and very few ventilation conditions have been studied. Therefore results give a guide for the magnitude of the compartment effects however more comparative test results are necessary for more quantitative recommendations

Therefore the following experimental work is recommended:

- More data in general would improve the statistical analysis, particularly 2-seater and 3-seater sofas
- Data on other fire characteristics, for example; combustion products, smoke production rates, mass loss rates

- Standardising outputs collected during experiments would ensure full sets of data, and allow comparisons between experiments
- Additional ISO room / free burn experimental pairs

### **Defining Design Fires**

The variables used to create the  $t^2$ -design fires had growth rates faster than ultra fast, some adjustment should be applied to create a design fire curve with a fast to ultra fast growth rate. However, the parameters and the methodology for this adjustment have not been assessed in this study and to quantify the adjustment requires further research.

The compartment effects were analysed for all furniture items as a whole, a more refined method would be required to consider the effects for each furniture item in isolation. This would require more data and further statistical analysis of all available data.

This thesis looked only at single upholstered furniture items. More data and research would be required to incorporate other types of furniture and item to item fire spread. In addition item to item fire spread requires consideration of compartment effects.

### **Design Fires with FDS**

As discussed in the conclusion the FDS results showed promise but at present there are a number of limitations, which need to be resolved.

Initially the reasons for the cap on the peak HRR and THR need to be determined and addressed. The significance of the pool fire effect on upholstered furniture fires also needs to be assessed and whether an algorithm in FDS is needed or a pool fire be added manually using a vent type function would be sufficient to aid the modelling of upholstered furniture.

The parameters, for which FDS can model individual items, and different types of items, need to be determined. Once FDS is able to model individual items and fire spread between items then could FDS be used to develop design fire scenarios. From which simplified design fires could be developed for use in design as standardised design fires.



## 10 References

- Andersson, B. and Magnusson, S.E. 1985. Fire Behavior of Upholstered Furniture - an Experimental-Study. *Fire and Materials*. 9(1): 41-45.
- Andersson, P., Blomqvist, P., Rosell, L., Simonson, M. and Stirrple, H. 2004. Environmental Effect of Furniture. INTERFLAM '04, Fire Science & Engineering Conference. Edinburgh, Scotland.
- Andrews, G.E., Ledger, J. and Phylaktou, H.N. 1999. Enclosed Pool Fires in Low Ventilation Enclosures: Flame Temperature and Global Heat Loss Using Gas Analysis. The Sixth International Symposium on Fire Safety Science. University of Poitiers, France, 5 - 9 July 1999.
- Apte, V., Edwards, A., Fleischmann, C.M., Hofstadler, J., Wade, C., Young, E. and Yung, D. 2005. Design Fires for Apartment Buildings - Literature Review. FQ5009-1 (2005). BRANZ Ltd, CSIRO & University of Canterbury 2005, Proirua City, New Zealand.
- Babrauskas, V., Lawson, J.R., Walton, W.D. and Twilley, W.H. 1982. Upholstered Furniture Heat Release Rates Measured with a Furniture Calorimeter. NBSIR 82-2604. U.S Department of Commerce National Bureau of Standards National Engineering Laboratory Center of Fire Researsch.
- Babrauskas, V. 1983. Upholstered Furniture Heat Release Rates - Measurements and Estimation. *Journal of Fire Sciences*. 1(1): 9-32.
- Babrauskas, V. 1985. Pillow Burning Rates. *Fire Safety Journal*. 8(3): 199-200.
- Babrauskas, V. and Krasny, J.F. 1985. Fire Behaviour of Upholstered Furniture. CIB W14/86/30 (USA). NBS Monograph 173.
- Babrauskas, V. 2002. Heat Release Rates. In The SFPE Handbook of Fire Protection Engineering, NFPA, Quincy, pp. 3-1, 3-37.
- Babrauskas, V.J. 1984. Upholstered Furniture Room Fires - Measurements, Comparison with Furniture Calorimeter Data, and Flashover Predictions. *Journal of Fire Sciences*. January/ February 1984. 2(1): 5 - 19.
- Benisek, L., Phillips, W.A. and Paul, K.T. 1985. The Burning Behavior of Bedding in Assembly and Component Tests. *Journal of Fire Sciences*. 3(1): 53-75.
- Blomqvist, J. and Andersson, B. 1985. Modelling of Furniture Experiments with Zone Models. *Fire and Materials*. 1985. 9(2): 81 - 87.
- Buchanan, A.H. (Ed.) 2001. Fire Engineering Design Guide. 2 edn. CAE, Christchurch, NZ.
- Chen, F.F. 2001. Radiant Ignition of New Zealand Upholstered Furniture Composites. Masters thesis, University of Canterbury.
- Cleary, T., Ohlemiller, T.J. and Villa, K. 1992. The Influence of Ignition Source on the Flaming Fire Hazard of Upholstered Furniture, NISTIR 4847. National Institute of Standards Technology, Washington DC.

- Cleary, T.G., Ohlemiller, T.J. and Villa, K. 1994. The Influence of Ignition Source on the Flaming Fire Hazard of Upholstered Furniture. *Fire Safety Journal*. 23(1): 79-102.
- D'Silva, A.P. and Sorensen, N. 1996a. The flammability aspects of decorative trimmings, Part 2: Decorative trimmings used on soft furnishings. *Journal of Fire Sciences*. 14(2): 94-103.
- D'Silva, A.P. and Sorensen, N. 1996b. The flammability aspects of decorative trimmings, Part 1: Flammability of trimmings used on upholstered furniture. *Journal of Fire Sciences*. 14(1): 26-49.
- D'Silva, A.P. 1998. The flammability aspects of decorative trimmings, Part 3: Decorative trimmings used on soft furnishings - A new test method. *Journal of Fire Sciences*. 16(4): 250-277.
- Damant, G.H., Williams, S.S. and McCormack, J.A. 1983. The Role of Fabric in the Cigarette Ignition of Upholstered Furniture. *Journal of Fire Sciences*. 1(5): 309-321.
- Damant, G.H. and Nurbakhsh, S. 1992. Heat Release Tests of Mattresses and Bedding Systems. *Journal of Fire Sciences*. 10(5): 386-410.
- Delichatsios, M.A. and Silcock, G.W.H. 2003. Fully Involved Enclosure Fires: Effects of Fuel, Type, Fuel Area and Geometry. The Seventh International Symposium on Fire Safety Science. University of Poitiers, France, 5 - 9 July 1999.
- Dembsey, N.A., Pagni, P.J. and Williamson, R.B. 1995. Compartment fire experiments: Comparison with models. *Fire Safety Journal*. OCT. 25(3): 187-227.
- Denize, H.R. 2000. The Combustion Behaviour of Upholstered Furniture in New Zealand. Masters thesis, University of Canterbury.
- Enright, P.A. 1999. Heat Release and the Combustion Behaviour of Upholstered Furniture. PhD thesis, University of Canterbury.
- Enright, P.A., Fleischmann, C.M. and al., e. 2001. CBUF model II applied to exemplary NZ furniture (NZ-CBUF). *Fire and Materials*. 25(3): 105-115.
- Fesman, G. and Jacobs, B.A. 1989. Evaluating the Flammability of Upholstered Furniture Intended for Public Occupancies. *Journal of Fire Sciences*. 7(6): 414-425.
- Firestone, J. 1999. An Analysis of Furniture Heat Release Rates by the Nordtest. Masters thesis, University of Canterbury.
- Flammability Information Package (contains Tb 116, 117, 121, 133, 106 and 26). 1987. Bureau of Home Furnishings, Department of Consumer Affairs, State of California, North Highlands, California.
- Fleischmann, C.M. and Parkes, A.R. 1997. Effects of Ventilation on the Compartment Enhanced Mass Loss Rate. The Fifth International Symposium on Fire Safety Science. World Congress Centre, Melbourne, Australia.
- Fleischmann, C.M. and Chen, F.F. 2001. Radiant Ignition of Upholstered Furniture. Proceedings of the International Conference on Engineered Fire Protection Design. Bethesda, Maryland.
- Fleischmann, C.M. and Parkes, A.R. 2005. **Draft.**
- Gallagher, J.A. 1993. Interliner Effect on the Fire Performance of Upholstery Materials. *Journal of Fire Sciences*. 11(1): 87-105.

- Girgis, N. 2000. Full-scale Compartment Fire Experiments on "Upholstered Furniture". Masters thesis, University of Canterbury.
- Harmathy, T.Z. 1979. Effect of the Nature of Fuel on the Characteristics of Fully-Developed Compartment Fires. *Fire and Materials*. 3(1): 49-60.
- Hertzberg, T., Sundström, B. and van Hees, P. 2003. Design Fires for Enclosures  
A first attempt to create design fires based on Euroclasses of linings. SP Report 2003:2. SP Swedish National Testing and Research Institute.
- Heselden, A.J., Thomas, P.H. and Low, M. 1970. *Fire Technology*. 6: 123.
- Hill, G.R. 2003. Burning Behaviour of Upholstered Furniture. Masters thesis, University of Canterbury.
- Hurley, M.J. and Quitere, J.R. 2003. Simple Fire Hazard Calculations. In A.E. Cote (Ed.), *Fire Protection Handbook*, 19 edn. NFPA, Quincy, Massachusetts, Vol. 1, pp. 3-147 -159.
- IFEG 2005. International Fire Engineering Guidelines.
- Ingham, P.E. and Edwards, R.J. 1984. The flammability of bedding materials. Wool Research Organisation of New Zealand, Christchurch.
- ISO 2003. Fire Safety Engineering - Selection of design fire scenarios and design fires, ISO/TC92/SC4/WG6 N65Rev (draft). International Standards Organisation, Geneva.
- Kallonen, R., von Wright, A., Tikkanen, L. and Kaustia, K. 1985. The Toxicity of Fire Effluents from Textiles and Upholstery Materials. *Journal of Fire Sciences*. 3(3): 145-160.
- Krasny, J.F. and Babrauskas, V. 1984. Burning Behavior of Upholstered Furniture Mockups. *Journal of Fire Sciences*. 2(3): 205-235.
- Krasny, J.F., Parker, W.J. and Babrauskas, V. 2001. *Fire Behavior of Upholstered Furniture and Mattresses*. Noyes Publications, Park Ridge, N.J.
- Lawson, J.R., Walton, W.D. and Twilley, W.H. 1983. Fire Performance of Furnishings as Measured in the NBS Furniture Calorimeter. Part 1. NBSIR 83-2787. U.S Department of Commerce National Bureau of Standards National Engineering Laboratory Center of Fire Research.
- Lawson, J.R.W., Walton, W.D. and Twilley, W.H. 1984. Fire Performance of Furnishings as Measured in the NBS Furniture Calorimeter. Part 1, NBSIR 83-2787. National Bureau of Standards, Washington DC.
- Lee, B.T. 1985. Effect of Wall and Room Surfaces on the Rates of Heat, Smoke, and Carbon Monoxide Production in a Park Lodging Bedroom, NBSIR 85-2998. Center for Fire Research, National Bureau of Standards, U.S. Department of Commerce, Washington DC.
- Liang, F.M., Chow, W.K. and Liu, S.D. 2002. Preliminary studies on flashover mechanism in compartment fires. *Journal of Fire Sciences*. MAR. 20(2): 87-112.
- Ljung, S. 2005. SP Fire Data Base: <http://www.sp.se/fire/fdb/frmLogon.aspx>. SP Swedish National Testing and Research Institute, 2006.
- Luo, M.C. and Beck, V. 1996. A study of non-flashover and flashover fires in a full-scale multi-room building. *Fire Safety Journal*. 26(3): 191-219.

- McCormack, J.A., Damant, G.H. and Williams, S.S. 1986. Cigarette Evaluation of 450 Pieces of Residential Upholstered Furniture. *Journal of Fire Sciences*. 4(2): 135-147.
- McCormack, J.A., Damant, G.H. and Hilado, C.J. 1988. Flammability Studies of 700 Articles of Upholstered Furniture. *Journal of Fire Sciences*. 6(2): 121-138.
- McGrattan, K. and Forney, G. 2004. Fire Dynamics Simulator (Version 4) User's Guide. NIST Special Publication 1019, NIST.
- Microsoft Office. 2003. Excel. Microsoft Corporation.
- NFPA 2003. Fire Protection Handbook. 19 edn. 2 vols., NFPA International, Quincy, Massachusetts.
- NIST 1999. FASTData, NIST Standard Reference Database Number 75, January 1999 Release. National Institute of Standards and Technology. 2005. <<http://www.fire.nist.gov/fastdata/>>.
- NSWFB 2003. New South Wales Fire Brigades Annual Statistical Report 2001/02 incorporating a ten year review 1989/90 to 1998/99. New South Wales Fire Brigades, Sydney South NSW.
- Nurbakhsh, S. 1991. Furniture Flammability Study .1. Development of Full Scale Fire Testing Facility. *Journal of Fire Sciences*. 9(5): 390-405.
- Nurbakhsh, S., Mikami, J.F. and Damant, G.H. 1991. Full Scale Fire Tests of Upholstered Furniture with Rate of Heat Release Measurements. *Journal of Fire Sciences*. 9(5): 369-389.
- Nurbakhsh, S. and McCormack, J. 1998. A review of the Technical Bulletin 129 full scale test method for flammability of mattresses for public occupancies. *Journal of Fire Sciences*. 16(2): 105-124.
- NZFS 2004. Emergency Incident Statistics. 1999-2003  
New Zealand Fire Service.
- Ohlemiller, T.J. and Villa, K. 1990. Furniture Flammability: An Investigation of California Bulletin 133 Test. Part II: Characterization of the California-Technical-Bulletin-133 Ignition Source and a Comparable Gas-Burner, NISTIR 4348. National Institute of Standards Technology, Washington DC.
- Ohlemiller, T.J. and Villa, K. 1992. Characterization of the California-Technical-Bulletin-133 Ignition Source and a Comparable Gas-Burner. *Fire Safety Journal*. 18(4): 325-354.
- Ohlemiller, T.J. and Shields, J.R. 1994. Furniture Mock-Up Performance Under California Technical Bulletin 133 Test Conditions. National Institute of Standards and Technology, Annual Conference on Fire Research, Gaithersburg, MD.
- Ohlemiller, T.J. and Shields, J.R. 1995. Behavior of Mock-Ups in the California Technical Bulletin 133 Test Protocol: Fabric and Barrier Effects, NISTIR 5653. National Institute of Standards and Technology, Gaithersburg, MD.
- Ohlemiller, T.J., Shields, J.R., McLane, R.A. and Gann, R.G. 2000. Flammability Assessment Methodology for Mattresses, NISTIR 6497. Building and Fire Research Laboratory, National Institute of Standards and Technology, Gaithersburg, MD.
- Ohlemiller, T.J. and Gann, R.G. 2002. Estimating Reduced Fire Risk Resulting From an Improved Mattress Flammability Standard, NIST TN 1446. National Institute of Standards and Technology, Githersburg, MD.

- Ohlemiller, T.J. 2003. Flammability Tests of Full-Scale Mattresses: Gas Burners Versus Burning Bedclothes, NISTIR 7006. National Institute of Standards and Technology, Gaithersburg, MD.
- Ohlemiller, T.J. and Gann, R.G. 2003. Effect of Bed Clothes Modifications on Fire Performance of Bed Assemblies, NIST TN 1449. National Institute of Standards and Technology, Gaithersburg, MD.
- Palisade Decision Tools - @Risk. 2004. BestFit. 4.5 edn. Palisade Corporation.
- Parkes, A.R. 1996. Under-ventilated compartment fires : a precursor to smoke explosions. Masters thesis, School of Engineering University of Canterbury.
- Parkes, A.R. and Fleischmann, C.M. 2005. The Impact of Location and Ventilation on Pool Fires in a Compartment. Proceedings of the 8th International Symposium on Fire Safety Science.
- Paul, K.T. 1980. Fire Testing of Upholstered Furniture and Bedding. *Fire and Materials*. 4(2): 92-97.
- Paul, K.T. 1989. Fire Testing of Bed Assemblies of Reduced Flammability. *Fire Safety Journal*. 14(4): 269-286.
- Paul, K.T. and King, D.A. 1990. The Burning Behavior of Domestic Upholstered Chairs Containing Different Types of Polyurethane Foams. *Fire Safety Journal*. 16(5): 389-410.
- Peatross, M.J. and Beyler, C.L. 1997. Ventilation Effects on Compartment Fire Characterization. The Fifth International Symposium on Fire Safety Science. World Congress Centre, Melbourne, Australia.
- Preble, E. 1998 - 2001. Grab IT! XP. Datatrend Software Inc.
- Rieber, M. 1983. Burning Characteristics of Beds and Bedding - Situation and Developments. *Fire and Materials*. 7(3): 157-162.
- Särdqvist, S. 1993. Initial Fires: RHR, Smoke Production and CO Generation from Single Items and Room Fire Tests. ISRN LUTVDG/TVBB\_\_3070\_\_SE. Lund University - Sweden  
Institute of Technology  
Department of Fire Safety Engineering, Lund.
- Schuhmann, J.G. and Hartzell, G.E. 1989. Flaming Combustion Characteristics of Upholstered Furniture. *Journal of Fire Sciences*. 7(6): 386-402.
- Söderbom, J., van Hees, P. and Meirsschaert, P. 1996. Influence of ignition sources on heat release rate in the furniture calorimeter. *Fire and Materials*. 20(2): 61-67.
- Spearpoint, M. 2001a. HRR Database: [http://www.civil.canterbury.ac.nz/spearpoint/HRR\\_Database/](http://www.civil.canterbury.ac.nz/spearpoint/HRR_Database/). University of Canterbury, January, 2006.
- Spearpoint, M. 2001b. The development of a web-based database of rate of heat release measurements using a mark-up language 5th AOSFT Conference. Australia.
- Sundström, B. 1994. Combustion Behaviour of Upholstered Furniture: Fire Safety of Upholstered Furniture: The Final Report on the CBUF Research Programme [S.I.]. Swedish National Testing and Research Institute, European Commission Standards, Measurements and Testing, Stockholm.
- Thomas, I.R. and Bennetts, I.D. 1999. Fires in Enclosures with Single Ventilation Openings - Comparison of Long and Wide Enclosures. The Sixth International Symposium on Fire Safety Science. University of Poitiers, France, 5 - 9 July 1999.

Thomas, P.H. and Smith, C.I. 2000. A note on fully developed fires in large compartments. *Fire Safety Journal*. JUL. 35(1): 67-69.

Wanna, J.T., Polo, A. and Schettino, D. 1996a. The smoldering potential of used upholstery fabrics: Unsoiled vs soiled. *Journal of Fire Sciences*. 14(2): 144-158.

Wanna, J.T., Rouse, C.A., Chen, P.L., Henderson, G.E. and Greear, L.C. 1996b. Smoldering potential and characterization of used upholstery fabrics. *Journal of Fire Sciences*. 14(5): 379-392.

Woolley, W.D., Ames, S.A., Pitt, A.I. and Murrell, J.V. 1976. Fire Behaviour of Beds and Bedding Materials. *Fire and Materials*. 1(2): 63-73.

## 11 Appendices

The appendices are on the attached CD.

***Appendix A:*** Upholstered furniture Database

***Appendix B:*** Extracts from Bestfit manuals

***Appendix C:*** Experimental data on growth rates

***Appendix D:*** Analysis of experimental data

***Appendix E:*** FDS simulations