

TIME-DEPENDENT LOAD PERFORMANCE OF NOTCHED WOOD-CONCRETE COMPOSITE BEAMS

Dr. R. Gutkowski, R. Fast
Colorado State University
Dept of Civil Engineering
Ft. Collins, CO 80523
U.S.A.

Dr. J. Balogh
Metro St. Coll. of Denver
Civil Eng. Technology
Denver, CO 80217
U.S.A.

Dr. M. Fragiacom
University of Canterbury
Dept. of Civil Engineering
Christchurch 8020
New Zealand

gutkowsk@engr.colostate.edu

KEYWORDS: Composite, beams, wood-concrete, creep, cyclic loading

INTRODUCTION

Researchers at Colorado State University (CSU) are examining the feasibility of using wood-concrete composite floor/deck systems as an alternative to concrete floor slab systems. The primary aim is to show that a structurally effective, durable solid wood-concrete layer can replace the cracked portion of the concrete slab and its rebar. Concrete needs a companion material to account for its lack of tension carrying ability. Wood is good in tension, if tension defects such as knots do not exist. Since the wood layer deck can replace the formwork for a solid slab, the gain is to leave it in place and use it structurally to reduce the concrete slab thickness by about 50% by interconnecting the wood and concrete layers. Ceccotti (1995) has closely examined wood-concrete flooring systems and provided a summation of many of the benefits compared to light frame wood floors. These include: 1) reduction of the vibration problems associated with timber structures, 2) an improvement of the sound insulation, 3) better fire resistance, 4) better seismic behaviour, and 5) reduction in the likelihood of catastrophic failure. The competitive merit of such mixed construction is borne out by several examples of successful commercial projects in Europe (Natterer, 1998). The concept has also been tried in the reconstruction of timber floors and ceilings (Toratti and Kevarinmaki, 2001).

Layered wood-concrete composites exhibit composite behavior that is it is bounded by two extreme limits. The upper limit ("fully composite") is when the interface between the layers is considered perfectly bonded and allows no relative motion ("slip"). The lower limit ("non-composite") is when the layers are completely unbounded with neither mechanical bond nor friction taking place between the two layers. For non-composite behavior, no interlayer shear transfer takes place. The actual circumstance is that the layer beam exhibits partial composite behavior while also experiencing slip between the layers. Actual systems are stiffer than the non-composite limit state while less stiff than the fully composite state.

Prior to conducting load tests of layered floor/deck specimens, preliminary load tests of layered wood-concrete beams were done by Fast et al. (2003). This included subjecting specimens to either creep tests and/or cyclic loading tests which simulate their typical service life. Results were used to evaluate the efficiency of the beam specimens as related to the degree of partial composite action achieved. Graphical and tabulated results presented herein are taken (with permission) from Fast et al. (2003) in the original units.

INTERLAYER CONNECTION

The interlayer connection system used is illustrated in Figure 1. This connection detail emanated from the research of Natterer et al. (1996). They used a sleeved dowel in a shear notch connection. The non-sleeved portion of the dowel is inserted into the wood and bonded with an adhesive. However, bonding is prevented between the concrete and the sleeved portion of the bolt. After curing of the concrete, the dowel is tightened to restore the tight fit around the notch so as to enable the interlayer force to be

transmitted by bearing in the notch materials. The notch dimensions and adhesive used are based on past CSU experimental studies [Thompson (1997), Brown et al. (1998), Eturnaud et al. (1998)]. The studies included withdrawal and load slip test of connections and exploratory beam tests. The adhesive used was Hilti HIT HY 150 glue.

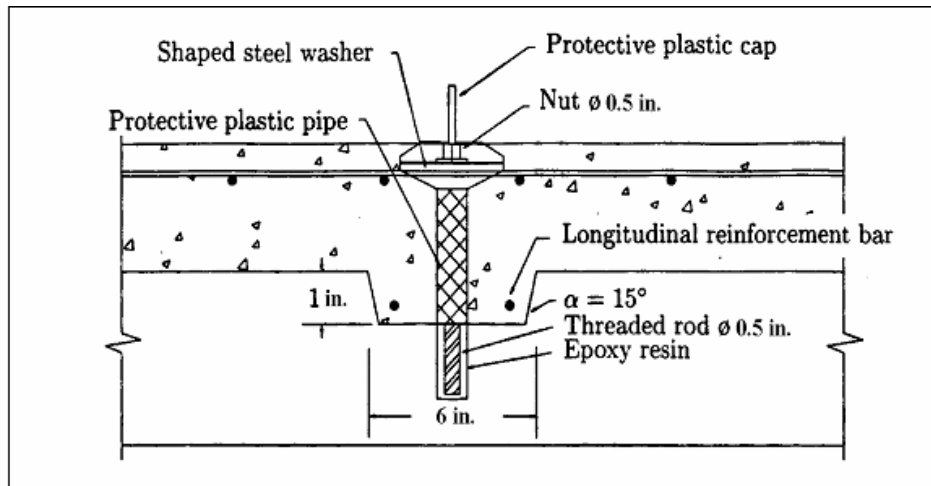

Figure 1- Notched Shear Key Hilti Dowel Connector Detail

WOOD-CONCRETE COMPOSITE BEAM PARAMETERS

Fig. 2 illustrates the cross-sections of the beams used in this research. They were constructed using four notched shear key connections spaced symmetrically over the 144 in (366 cm) length of the simply supported beam.

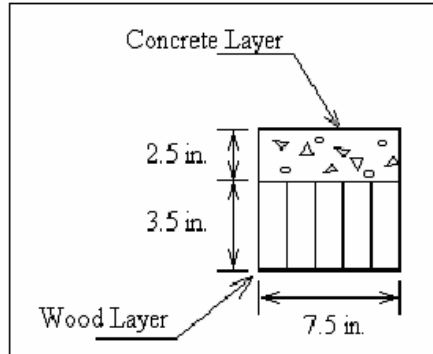

Figure 2- Beam Schematic End View

MATERIAL PROPERTIES

The compressive strength, f_c , of the concrete was determined by cylinder tests using American Society for Testing and Materials standards. Accordingly five cylinders were tested at the 28-day point for each batch of beam test. The time effect (until the beam specimens were tested) on the concrete properties of individual specimens was not taken into account. Using the measured compressive strength the modulus of elasticity, E_c , was calculated according to Eq. 1 (ACI Building Code Requirements 2002), which is based on U.S. Customary units.

$$E_c = 57,000 (f_c)^{1/2} \quad (1)$$

Two batches of beams were made. The first batch (creep test specimens) had an average E_c equal to 3790 ksi (26 kN/mm²) while the second batch (cyclically tested specimens) had an average E_c equal to 3500 ksi (24 kN/mm²).

All dimension lumber was surface-dry Grade 2, of the Hem-Fir species. The modulus of elasticity of the wood was measured by a flexural test of the individual pieces (Fast et al. 2003). It is important to note that the shear deformation was included in the measured values. Values ranged from 975 ksi (6.7 kN/mm²) to 1529 ksi (10.5 kN/mm²) with the average being 1248 ksi (8.6 kN/mm²).

QUANTIFICATION OF COMPOSITE ACTION AND STIFFNESS

The objective of the research performed was to quantify the degree of composite action that takes place within the wood-concrete composite beams. This was done using Equations 2, 3 and 4, which are based on Pault and Gutkowski's work (1977).

$$CAA = (\Delta_N - \Delta_C) / \Delta_N \quad (2)$$

$$EFF = (\Delta_N - \Delta_I) / (\Delta_N - \Delta_C) \quad (3)$$

$$CAO = EFF * CAA \quad (4)$$

where:

Δ_N = the theoretical deflection for fully non-composite beam,

Δ_C = the theoretical deflection for fully composite beam, and

Δ_I = the measured deflection for the partially-composite actual specimen.

CAA is the maximum % Composite Action Available theoretically, EFF is the efficiency exhibited by the actual test specimen. CAO is the % Composite Action Observed in the actual test specimen. The fully composite deflection was calculated using the ordinary beam deflection equation for the test loading case and moment of inertia of the transformed cross-section. The fully non-composite deflection was calculated by using the same deflection equation and the moment of inertia was the sum of the individual centroidal values of concrete (transformed) and the wood layers.

SPECIMEN CONSTRUCTION

For each specimen the five twelve foot long boards were nailed together using a nail template. "Ring-shank" nails were used to insure a high resistance to withdrawal and thus form tightly joined members. The shear notches were cut out and the sleeved Hilti dowels were installed. A protective plastic cap was inserted over the head of the bolt to prevent bonding to the concrete.

Side formwork was then built for each beam and concrete was placed on top of the wood layer. Due to the long duration of the creep tests it was necessary to cast these beams at a much earlier time than those that would be used for the other types of tests. The only difference between the two concrete castings was that the casting for the creep test specimens was vibrated by hand while an electrical vibrator was used for beams subjected to the cyclic loading. After the concrete was placed, plastic insulation sheets were placed over the concrete to help it cure, and were removed after 7 days of curing. At that time the protective caps were removed from the top of the dowels and 20 ft.-lbs. (27 N·m) of torque was applied to the nut on each dowel. The beams were then allowed to cure until the planned tests were conducted.

Moisture content of the wood was monitored within several of the specimens beginning shortly after the concrete had been placed. A Delmhorst R-2000 Wood Moisture Meter was used with numerous 1.5 ins. (38 mm) long moisture pins placed into the sides of the specimen. For the two moisture reading points closest to the wood-concrete layer, the trend was downward and never exceeded 20%, considered as a

demarcation for possible decay. Each beam used in the cyclic tests was then submersed in a tank of water for 24 hours and then placed in an environmental chamber. The environmental chamber was maintained at a constant 68% humidity and 33°C temperature level allowing the beams to equilibrate at a moisture content level of approximately 12%. The beams were kept at that condition until the load tests. The creep test specimens were cast in-place on an elevated test frame. Hence they were only subjected to the ongoing lab environmental condition.

DESCRIPTION OF THE CREEP LOAD TESTS

Initially, during the construction of the beams used for the creep test, four of the eight beams were vertically supported at the one-third points. This “shoring” was removed after a 36 day curing period, and no noticeable results in the overall creep behavior of the beam was noticed between the shored and the non-shored specimen. The creep test consisted of suspending 450 lbs. (4 kN) vertical loads at the one-third and two-third points along the span of simply supported specimen and monitoring the deflections with respect to time. The total load of 900 lbs. (8 kN) corresponded to an estimated 12.5% of the ultimate capacity of the beam. Prior to loading, an initial reading of the mid span deflections was taken using string potentiometers. After applying the load, a reading of mid span deflections was taken every 24 hours for the first 10 days. Subsequent readings were taken weekly for the duration of test. The mid span deflections were still significantly increasing after 90 days of loading. Thus, the mid span deflections were monitored for 45 more days. Four of the specimens were then removed and subjected to additional load tests.

RESULTS OF THE CREEP LOAD TESTS

Figure 3 contrasts mid span deflection data for all beam specimens over the course of 135 days. Table 1 lists the partial results. The median value for the eight specimens was 0.496 in (12.6 mm) with an average value of 0.514 in (13.1 mm). The percent increase of the deflection due to creep at 135 days had a range of 52.8% - 60.9%, with an average value of 57.5% deflection. Beams 1, 2, 5, and 6 were selected as the creep test specimens to be subjected to the ultimate capacity tests. The others were left in place for continuing creep loading.

Table 1-Creep Test Data and Summary Statistics

Creep Specimen Beam No.	Creep Test after 1 hr. 50 min. Initial Midspan Deflection (in)	Creep Test after 135 days Total Midspan Deflection (in)	Percent Increase of Deflection from Initial to Total Deflection
1	0.2678	0.4286	60.0%
2	0.2829	0.4551	60.9%
3	0.3139	0.4942	57.4%
4	0.3174	0.5097	60.6%
5	0.3660	0.5874	60.5%
6	0.4345	0.6643	52.9%
7	0.3072	0.4762	55.0%
8	0.3251	0.4968	52.8%
Maximum:	0.4345	0.6643	
Minimum:	0.2678	0.4286	
Median:	0.3157	0.4955	
Average:	0.3268	0.5140	
Standard Deviation:	0.0523	0.0764	

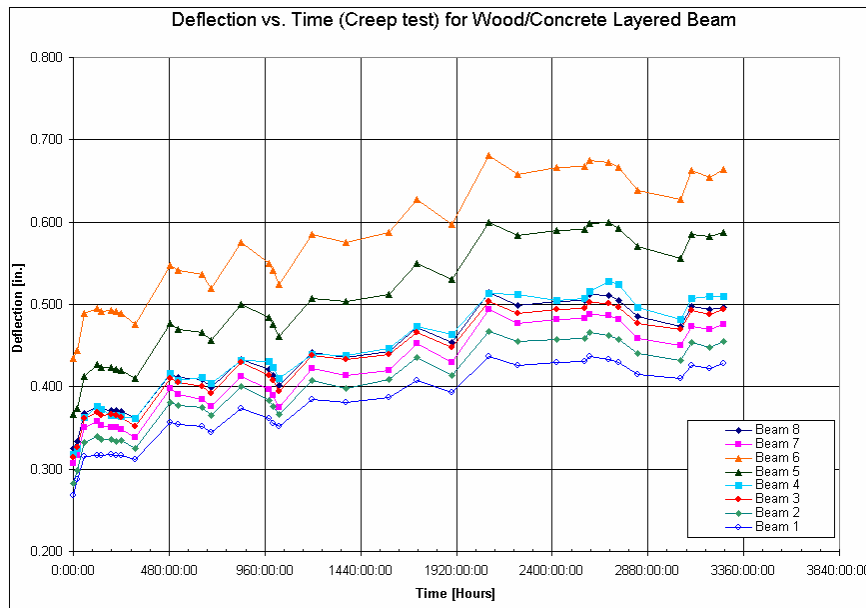

Figure 3-Comparison of Raw Data from 135-day Creep Test

DESCRIPTION OF THE CYCLIC LOAD TESTS

The purpose of the cyclic load tests was to simulate the deflection behavior due to long-term live load applications in commercial building. For the first specimen, a trial mid span load was oscillated sinusoidally at set frequencies starting with an amplitude of 700 lbs. (3.1 kN). Upon application of this base load the load was cycled up to 1250 lbs. (5.6 kN) and back to 700 lbs. (3.1 kN) for 21,600 cycles. The load rates were 14 cycles/minute for cycles 0-7,200, 6 cycles/minute for cycles 7,200-14,400, and 10 cycles/minute for cycles 14,400 – 21,600. Deflection at the quarter points, mid span, and the slip at all four notches was monitored using potentiometers. Figure 4 illustrates the deflection results for the first specimen. The percent increase in mid span deflection steadily decreases in value and essentially levels off by the end of the 21,600 cycles. An amplitude of about 1300 lbs. (5.8 kN) and a load rate of 15 cycles/minute were used for the remaining specimens. Upon completion of the cyclic loading test the ramp load to failure ensued.

CYCLIC TEST RESULTS

Twelve beams were conditioned as described earlier and then cyclically loaded. Prior to any load test taking place on a given beam specimen, the specimen was ramp loaded between 0% and 25% of its estimated capacity several times until repeatability of the mid span deflection was attained. A linear regression curve was fit to the slope of the resulting load vs. mid span deflection plot to quantify the “initial stiffness” of the specimen. Similarly a linear regression curve was fit to the data obtained during the ultimate load test to determine the “final stiffness.” The maximum percent change in stiffness for the cyclically loaded beams occurred in specimen RB309 at 44.1%. This data was questioned due to its extreme difference from all the other beams tested. Neglecting test questionable datum, the percent difference between the initial stiffness and final stiffness ranged of 6.4% and 24.1%, the average value being 15.1%.

Figure 5 is a chart of the typical behavior exhibited in the cyclically tested specimens. Table 2 lists the initial and final mid span deflections at the completion of the cyclic loading. For the twelve specimens the percent increase from initial deflection to final deflection ranged between 7.3% and 16.4%. The average value was 14.2%. Only a slight drop (< 0.5%) in the moisture content of the timber had taken place during the tests.

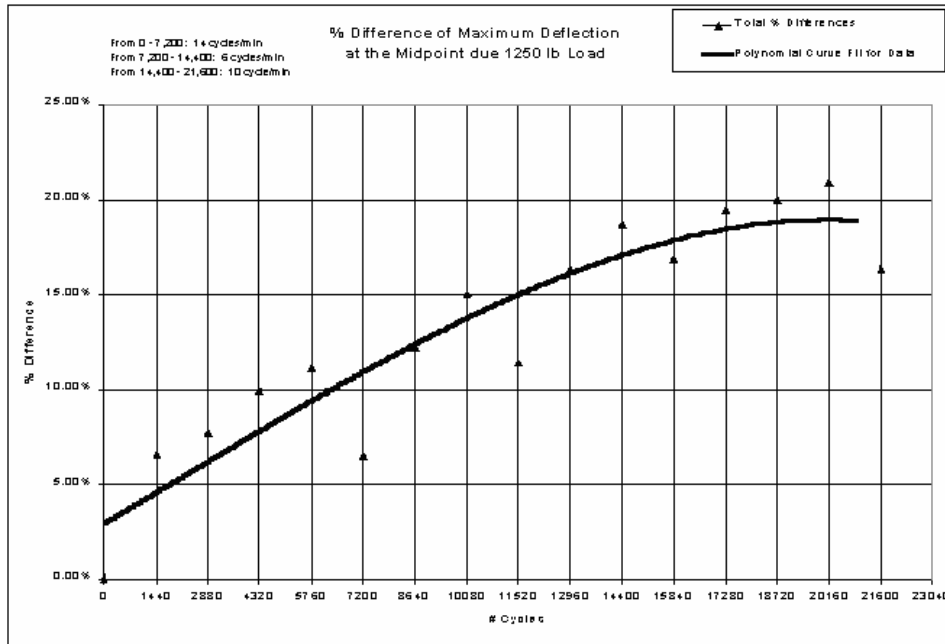

Figure 4-Percent Difference of Midpoint Deflection versus # Cycles Indicating Steady State Condition

Table 2-Statistics for Percent Increase in Mid span Deflection During Cyclic Load Test

Specimen Designation	Load Deflection Results Prior to any Cycles		Load Deflection Results After 21,600 Cycles		% Increase in Deflection
	Load (lb)	Deflection (in)	Load (lb)	Deflection (in)	
RB301	1297	0.597	1305	0.699	14.6%
RB303	1293	0.543	1302	0.628	13.5%
RB306	1282	0.527	1304	0.618	14.7%
RB309	X	X	1303	0.480	X
RB310	1281	0.468	1295	0.547	14.4%
RB401	1315	0.459	1313	0.538	14.8%
RB402	1246	0.824	1256	0.890	7.3%
RB403	1300	0.466	1306	0.541	13.8%
RB404	1293	0.468	1296	0.554	15.6%
RB406	1284	0.475	1293	0.568	16.4%
RB407	1291	0.427	1308	0.510	16.2%
RB408	1292	0.470	1307	0.557	15.6%
Average:	1289	0.520	1299	0.594	14.2%

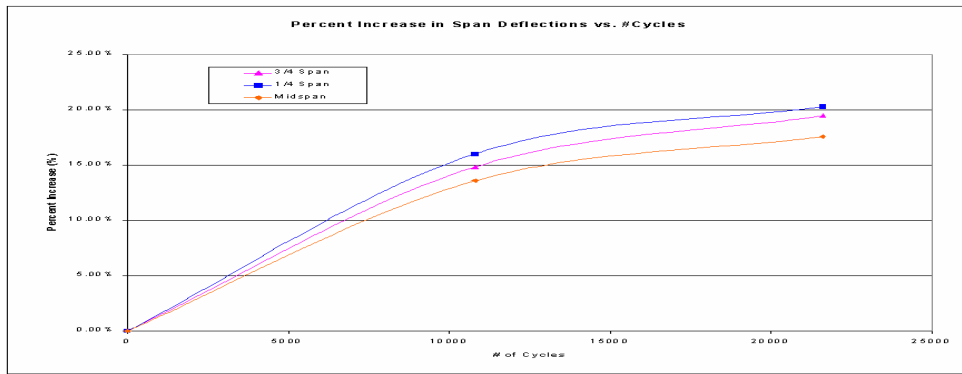

Figure 5.4 – Percent Increase vs. # of Cycles

Figure 5-Typical Behavior for the Cyclically Loaded Beam Specimens

RESULTS OF ULTIMATE LOAD TESTS

Two failure modes were observed in the ultimate load tests for the cyclically loaded beam specimens. Some failed at or near the mid span due to the flexural tension limit being exceeded in the bottom (wood) portion of the beam (“Midspan Failure”). Figure 6 illustrates a typical mid span load vs. deflection diagram for this type of failure. After a fairly linear load-deflection response a sudden failure is induced and the beam loses much of its load carrying capacity. In the other specimens a block shear failure of the wood notch occurred. Failure mode was initiated by a crack or splitting of the wood starting at the base of the notch nearest the end running parallel to the grain of wood until it reached the end of the beam. Figure 7 illustrates a typical load vs. deflection diagram for this type of failure. Initially the load peaks just prior to the block shear failure at which time the load carrying capacity of the beam decreases significantly. The beam continues to carry load until a secondary mode of failure, exhibited by a flexural tensile failure occurs at the mid span. Table 3 provides a summation of the failure loads and the failure types for the twelve beams subjected to the cyclic loading. The results of the ultimate capacity tests had a range of 2057 – 4211 lbs. (9.2 – 18.7 kN), with an average failure load of 3515 (15.6 kN). Table 4 illustrate the significant difference between the failure loads of the two different failure types.

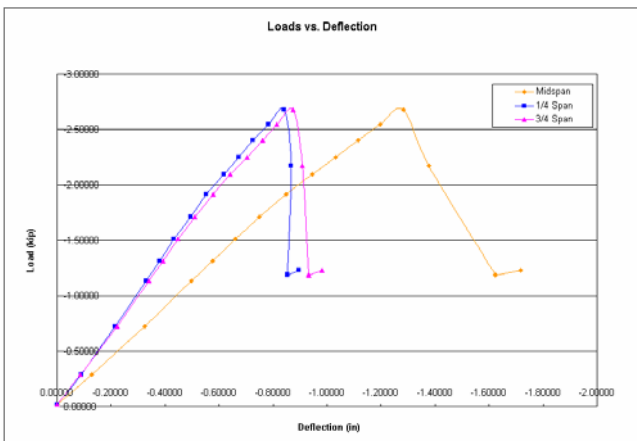

Figure 6-Typical Midspan Load vs. Span Deflections for Specimen RB303

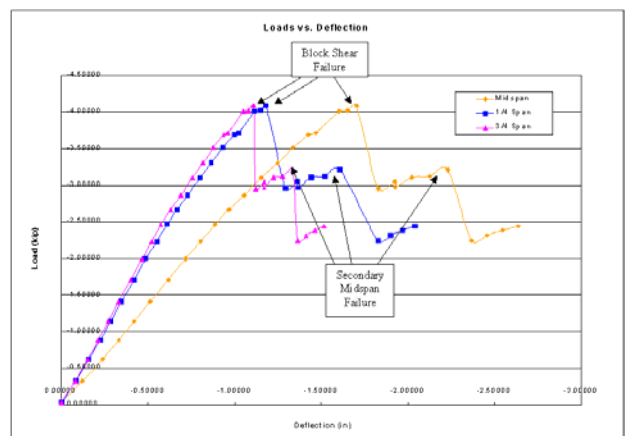

Figure 7-Midpoint Load vs. Span Deflections for Specimen RB407

Table 3-Results of Ultimate Load Test

Specimen Name	Midpoint Load (lb.)	Type of Failure
RB301	3067	Midspan
RB303	2680	Midspan
RB306	3407	Midspan
RB309	2057	Midspan
RB310	3778	Block Shear
RB401	4148	Block Shear
RB402	2967	Midspan
RB403	4211	Block Shear
RB404	4136	Block Shear
RB406	3729	Block Shear
RB407	4091	Block Shear
RB408	3914	Block Shear
Maximum	4211	Block Shear
Minimum	2057	Midspan
Average	3515	

Table 4-Statistical Results for Mid span and Shear Block Failure Types

Statistical Value	Failure Load for Midspan Failure Type (lb.)	Failure Load for Block Shear Failure Type (lb.)
Maximum	3407	4211
Minimum	2057	3729
Median	2967	4091
Average	2836	4001
Standard Deviation	507	193

Table 5 provides a statistical synopsis of the composite behavior observed for the twelve beam specimens subjected to cyclic loading, prior to the ultimate load test to failure. Every beam that was subject to the mid span failure type had a noticeable defect (knots, nails, cracks, etc) located at or near the mid span, in at least one board. For these beams the ultimate capacity and efficiencies were much lower when compared to those that failed by the block shear failure mode.

After the 135 days of creep loading the four specimens were ramp loaded to failure. All the specimens failed in the block shear failure type. This failure type was observed to take place instantly at which time the load carrying capacity of the beam decreased significantly but would remain high enough to induce a secondary mid span mode of failure. The ultimate loads at initial failure ranged between 1916 lb. (8.5 kN) and 2786 lb. (12.4 kN) and the average failure load was 2316 lb. (10.3 kN).

Due to the need to cast the creep specimens on top of an elevated concrete frame in it was not possible to evaluate their initial stiffness. Tabulated final stiffness results are provided in Table 6.

OBSERVATIONS

According the FPL Wood Products Handbook (1999) the total deflection due to creep loading in a timber beam at 135 days should be 66% of the initial elastic deflection. Typical reinforced concrete beams at 135 days should exhibit deflection due to creep that is between 65% and 70% of the initial elastic deflection (Portland Cement Association 2002). The average percent increase in deflection over the course of 135 days of creep loading for the wood-concrete beams was 57.5%, which appears reasonable. The lower value is attributed to the small magnitude of load applied (12.5% of ultimate).

Table 5 - Efficiency of Specimens

Statistical Results of Composite Behavior for All Cyclically Loaded Beams (12 beams)				
Sample Size	Statistical Value	Composite Action Available	Efficiency	Composite Action Observed
n = 12	Maximum	74.7%	69.8%	52.1%
	Minimum	72.8%	40.6%	30.1%
	Median	74.1%	60.0%	44.5%
	Average	74.1%	60.5%	44.8%
	Standard Deviation	0.60%	8.51%	6.41%
Statistical Results of Composite Behavior for Block Shear Failure Type Cyclically Loaded Beams (7 beams)				
Sample Size	Statistical Value	Composite Action Available	Efficiency	Composite Action Observed
n = 7	Maximum	74.7%	69.8%	52.1%
	Minimum	74.1%	58.7%	43.9%
	Median	74.5%	66.8%	49.5%
	Average	74.5%	64.6%	48.1%
	Standard Deviation	0.24%	5.01%	3.65%
Statistical Results of Composite Behavior for Midspan Failure Type Cyclically Loaded Beams (5 beams)				
Sample Size	Statistical Value	Composite Action Available	Efficiency	Composite Action Observed
n = 5	Maximum	74.1%	66.5%	49.1%
	Minimum	72.8%	40.6%	30.1%
	Median	73.7%	54.6%	39.8%
	Average	73.5%	54.8%	40.2%
	Standard Deviation	0.54%	9.57%	6.96%

Table 6 – Stiffness Composite Behavior Results for Creep Tested Beam Specimens

Specimen Name	Stiffness (lb/in)
RB501	1810
RB502	1658
RB505	1775
RB506	1674
Maximum	1810
Minimum	1658
Average	1729

The cyclically loaded beams whose primary mode of failure of the wood was due to flexural failure of the wood at the mid span, had an average ultimate capacity that was nearly 1200 lbs (5.3 kN), less than those whose primary mode of failure was due to block shear at the end of the beam. When the wood portion of the composite did not have a knot, or a nail, or some other defect at the mid span, the beam was able to develop its load carrying capacity concentrating the stresses not at the mid span but at the base of the notch nearest the beam's end as predicted by Wieligmann et al. (2003). This optimum behavior results in higher ultimate capacity and efficiency of composite action.

Since all of the creep test specimens had no defects at or around the mid span and failed in the block shear failure type, it is reasonable to conclude that the maximum load carrying capacities of the

specimens were being reached. In addition the average final stiffness of the cyclically loaded beams had an average of 2190 lb/in (380 kN/mm), while the average stiffness found for the creep load specimens was 1730 lb/in. (300 kN/mm), significantly lower. This suggests that the applied dead load had a more significant effect on decreasing the long-term stiffness than the applied live load.

CONCLUSIONS

The following are conclusions drawn from the research:

- Moisture pockets did not form between the wood and concrete layers during any part of their construction or environmental conditioning that would induce rot or decay in the wood portion of the composite specimen.
- As the number of cycles increased to 21,600, the stiffness of the beam levels off at a constant stiffness value.
- Tension face defects in the timber portion of wood-concrete composites have a dramatic impact on their failure modes and ultimate load capacities, and resulting composite behavior.
- Beams, subjected to a ramp test to failure exhibited two failure types. The mid span flexural failure types always occurred around a defect in the wood, while the block shear failure type could not be attributed to any such defect.
- Test results indicate that long-term dead loads, leading to creep, have a greater effect on lowering the stiffness and efficiency in a wood-concrete beam than do long-term cyclic loads.

REFERENCES

Brown, K. T., Gutkowski, R. M., Peterson, M.L., Criswell, M.E. *Testing of a Shear Key/Anchor in Layered Wood-Concrete Beams.* Structural Research Report No. 76, Civil Engineering Department, Colorado State University, Fort Collins, Colorado, 1998.

Building Code Requirements for Structural Concrete (ACI 318-02) and Commentary (ACI 318R-02), American Concrete Institute, Farmington Hills, Michigan, 2002 Edition.

Ceccotti, A. Timber-concrete composite structures. *Timber Engineering, Step 2*, First Edition, Centrum Hout, The Netherlands, 1995, pp. E13/1-E13/12.

Design and Control of Concrete Mixtures, Portland Cement Association, 14th Edition, 2002.

Etournaud, P. J., Gutkowski, R. M., Peterson, M. L., Criswell, M.E. *Load Test of Composite Wood-Concrete Decking Under Point Loads.* Structural Research Report No. 81, Civil Engineering Department, Colorado State University. Fort Collins, Colorado, October 1998.

Fast, R.S., Gutkowski, R.M., Criswell, M.E., and Radford, D.W. *Durability Studies of Layered Wood-Concrete Connections and Beams.* Structural Research Report No. 84, Civil Engineering Department, Colorado State University, Fort Collins, Colorado. 2003

Natterer, J., Hamm, J., Favre, P. *Composite Wood-Concrete Floors for Multi-story Buildings.* Proceedings of the International Wood Engineering Conference. New Orleans, Louisiana, October 28-31, 1996, pp. 3431-3435.

Natterer, J. *Wood Utilization Using New Technologies for Timber Engineers.* Proceedings of the 5th World Conference on Timber Engineering, Vol. 1, Montreux, Switzerland, August 17-20, 1998, pp. 7-15.

- Pault, J.D., Gutkowski, R. M. *Composite Action in Glulam Timber Bridge Systems*. Structural Research Report No. 17 B, Civil Engineering Department, Colorado State University. Fort Collins, Colorado, 1977.
- Thompson, W. *Slip Tests of Wood-Concrete Composite Specimens*. Plan B Masters Report, Civil Engineering Department, Colorado State University, Fort Collins, Colorado, 1997.
- Toratti, T., Kevarinmaki, A. *Development of Wood-Concrete Composite Floors*. IABSE Reports, Vol. 85, 2001, pp. 513-518.
- Wieligmann, M., Balogh, J., Gutkowski, R. M., Haller, P. *Strain-Stress Behavior of Dowel Connections for Partially composite Wood-Concrete Floors and Decks*. Structural Research Report, Colorado State University, Fort Collins, Colorado, Spring 2003.
- Wood Handbook - Wood as an Engineering Material*, Gen. Tech. Rep. FPL-GTR-113. Forest Products Laboratory, Madison, WI: U.S. Department of Agriculture, Forest Service, Forest Products Laboratory, 1999, 463p.