

DEVELOPMENT OF A PORTABLE MILKING PLATFORM FOR OVINE DAIRY USING THE TRIZ DESIGN METHODOLOGY

A thesis submitted to fulfil the requirements for the degree of
Master of Engineering,
specialising in Mechanical Engineering
at the University of Canterbury

Thomas James Frewen

January 2018

Abstract

This project developed a portable sheep milking plant from a 16-unit single aside plant using the TRIZ methodology. This project was completed at Read Industrial Ltd and the Mechanical engineering postgraduate offices.

The application of the TRIZ methodology for design improvement required adequate background research into milking plant design, including sheep milk applications. This was used, in part to identify non-compliant practices and designs that are used in a portable milking platform from the code of practice for dairies (NZCP1). Amendments were made to the NZCP1 document to be more applicable for sheep and transportable dairy designs and practice. Compliance to the NZCP1 was required as part of the risk management programme required for the sale of milk to processors for the current milking plant as well as the optimised plant. The amendments were accepted by the Ministry of Primary Industries as part of the risk management programme of the 16 unit single aside milking plant.

The application of the TRIZ methodology required the identification of issues or problems in the design and operation. Any unapparent issues of the 16-unit portable milking plant were identified using a function map and trimming. The abstraction of the problematic functions of the identified issues was used to ascertain the contradiction causing the issue. The TRIZ methodology was applied using the identified contradictions to identify particular inventive principals to be used to focus the idea generation process. The main contradiction for the plant optimisation was to improve the production capability of the milking system, while retaining within the maximum envelope of a trailer. The inventive principals yielded concepts designs that improved the production capabilities. A rotary system was selected as it allowed continuous operation that is not available on the single aside plant. Due to the size constraints, the rotary plant platforms were divided into segments that fold upwards and over each other to fit within the maximum trailer width during transport. The milking component layout and processes were optimised for the rotary plant and components were selected and designed to be more applicable than the previous single aside plant.

The 20 bail rotary system was developed using computer aided design (CAD) and finite element analysis (FEA) software to ensure that the designed platforms and trailer were able to withstand the applied loading without deformation or excessive stress. The trailer utilised an articulating axle at the front of the trailer for added manoeuvrability and weight distribution and was compliant with the agricultural vehicle guidelines that the previous portable milking system used.

Acknowledgements

Many thanks goes to the many people that have contributed and assisted with the project. Your assistance during the project directly or indirectly has aided in the development this project and the experience I learnt throughout this project is invaluable.

In particular, I would like to thank my supervisor Paul Docherty who provided advice and mentoring throughout the project. Additionally, Ian MacDonald as an industry mentor who gave insights into the dairy regulations and administration required for the operation of the portable milking plant as well as providing an understanding of the sheep milking industry nationally and worldwide. Furthermore, thanks to the staff at Read Industrial Ltd for their time, experience and dependable advice of milking systems design.

In addition, I would like to express my gratitude to friends and family for their personal and moral support throughout the project. I especially would like to thank my parents Neville and Sue, my brother Colin, and my grandparents who have provided constant support and motivation throughout the project.

Subsequently, I am appreciative to Callaghan Innovation who provided a research grant used for this project and the Te Punenga grant that assisted with travel funds to attend the 2017 Sheep Milk NZ conference.

Abbreviations/Glossary

TRIZ – Theory for Inventive problem solving

MS – Milk solids

NZCP1 – New Zealand code of practice for dairy design

RMP – Risk management programme

ACR – Automatic cluster removal

EID – Electronic identification tag

CIP – Cleaning in place

CAD – Computer aided design

FEA – Finite element analysis

MPI – Ministry of Primary Industries

Table of Contents

1	Background	8
1.1	Milk	8
1.1.1	Cows (Bovine).....	8
1.1.2	Sheep (Ovine).....	9
1.1.3	Properties of sheep milk	12
1.1.4	Uses.....	13
1.2	Milking.....	15
1.2.1	Milking systems.....	15
1.2.2	Plant design.....	19
1.2.3	Milking platform system types and additional systems	23
1.2.4	Unique ovine characteristics.....	24
1.3	TRIZ design	25
1.3.1	Abstraction.....	25
1.3.2	Contradictions.....	25
1.3.3	Technical parameters.....	26
1.3.4	Inventive principals.....	26
1.3.5	Ideality.....	27
1.3.6	Trimming.....	27
1.3.7	Worked example.....	28
2	Investigation.....	31
2.1	Development of current prototype	31
2.1.1	Initial prototype	31
2.1.2	Developed prototype.....	31
2.2	TRIZ evaluation of current system and implications for system development	33
2.2.1	Production analysis.....	33
2.2.2	Component analysis.....	37
2.3	Component layout	38
2.3.1	Ergonomics.....	38
2.3.2	Systems layout	39
3	Development/Optimisation	40
3.1	Design criteria	40
3.2	Manufacturing capabilities of Read Industrial Ltd.....	40
3.3	System design	41
3.3.1	Concept development.....	41
3.3.2	Concept evaluation	44
3.3.3	Concept development/design iterations	46
3.4	Embodied design.....	46

3.4.1	Milking system	46
3.4.2	Effluent disposal system	57
3.4.3	Trailer design.....	58
3.4.4	Operational procedures	59
3.5	Evaluation	59
3.5.1	Component evaluation	59
3.5.2	Production and component layout analysis	60
3.5.3	TRIZ reflection	60
4	Modelling	61
4.1	Computer aided design (CAD).....	61
4.2	Finite element analysis (FEA)	62
4.2.1	Geometry	62
4.2.2	Material properties.....	62
4.2.3	Connections	62
4.2.4	Meshing.....	62
4.2.5	Loading.....	62
4.2.6	Solver.....	63
4.2.7	Structural loading.....	63
4.2.8	Validation	68
5	Supplementary contributions to the field	69
5.1	Design and operation of farm dairies operational code (NZCP1)	69
5.1.1	Modifications to NZCP1	69
5.2	Risk management Programme (RMP).....	69
5.2.1	Evaluation.....	69
5.2.2	Technical assessment.....	69
5.2.3	Verification.....	70
5.3	Validation for milk storage.....	70
5.3.1	Farm dairy assessment of current plant	70
5.3.2	Approval.....	70
6	Conclusions	71
6.1	TRIZ methodology	71
6.2	Milking plant	71
6.3	Trailer design.....	72
6.4	Summary	72
7	Potential further work	73
7.1	Maximising the utilisation of the milking plant	73
7.2	Sheep genetics	73
7.3	Value-added products.....	73
8	References	74

9	Appendix	79
9.1	A - Function Map.....	79
9.2	B - Modifications to NZCP1	81

List of tables

Table 1- Common sheep breeds of New Zealand	10
Table 2 - Milking sheep breeds	11
Table 3 - Nutrient concentrations of dairy effluent of sheep cow and goat	12
Table 4 - Chemical and nutritional composition of various types of milk	12
Table 5 - Inventive principals and produced ideas for worked example	29
Table 6 - Separation type and generated ideas for worked example.....	29
Table 7 - TRIZ Inventive Principals for Optimising the Productivity of the Portable Sheep Milking Plant	33
Table 8 - Variable values used and description	49
Table 9 - Maximum volume of milk produced from 1/20 stalls using various diameters of milklime and slope.....	50
Table 10 - Material properties of the structural steel members	62

List of Figures

Figure 1 - Milking Machine System Diagram (Accessed from NZCP1('Operational Code: NZCP1: Design and Operation of Farm Dairies'))	16
Figure 2 - Bucket milking plant	20
Figure 3 - Herringbone milking plant	22
Figure 4 - External rotary platform	23
Figure 5 - Trimming of Components and Functions Sourced from TRIZ for Engineers (Gadd).....	28
Figure 6 - 16 Signal aside portable sheep milking plant	31
Figure 7 - Fundamental milking system analysis	32
Figure 8 - Side by side concept	41
Figure 9 - Under and over concept sketch	42
Figure 10 - Taco design concept sketch	43
Figure 11 - Butterfly concept sketch	43
Figure 12 - Track concept sketch	44
Figure 13 - Ferris wheel concept sketch	44
Figure 14 - Foldaway and flower sketches.....	46
Figure 15 - Process diagram for the portable rotary milking plant.....	47
Figure 16 - Rotating system without ACR rams to show component placement.....	48
Figure 17 - Rotating platform.....	48
Figure 19 - Rotating platform (platforms down).....	49
Figure 18 - Rotating platform (platforms folded away)	49
Figure 20 - ACR and bail ram mounting configuration	52
Figure 21 - Typical rotary ACR system	53
Figure 22 - Mock-up of platform and cluster positioning	53
Figure 23 - Rotary drive system	56
Figure 24 - Trailer chassis.....	58
Figure 25 - Plant layout.....	61
Figure 26 - Drawbar tension loading.....	64
Figure 27 - Drawbar compression loading	64
Figure 28 - Drawbar transverse loading.....	65
Figure 29 - Platform vertical loading.....	66
Figure 30 - Trailer frame vertical loading.....	67
Figure 31 - Trailer frame vertical and moment loading	68

1 Background

1.1 Milk

Milk is the primary source of nutrition for young mammals before weaning. Humans consume milk produced by cows, goats, sheep, or other animals as food in itself, or the milk products that the produced from the milk such as cheese and yoghurt (Collins). Milk has become an established food in most cultures around the world.

The following sections give an outline to the bovine (cow) dairy industry, which produces the majority of milk worldwide and in New Zealand, and ovine (sheep) dairy industry, which is developing in New Zealand.

1.1.1 Cows (Bovine)

In New Zealand, specialised breeds of dairy bovine cattle (cows) produce the milk consumed in New Zealand and exported worldwide. New Zealand dairy cow milking season is typically mid-winter through to mid-spring, after calving, and milked until they are 'dried off' generally in late summer and autumn in the following year or when required.

There are slightly less than five million dairy cattle in New Zealand (4,997,881), which overall produced in total more than 20 billion litres of milk for processing in the 2015/2016 milking season. The average herd size in New Zealand remained steady at 419 in the 2014/2015 and 2015/2016 seasons. However, the herd size has increased by almost 100 cows in the last ten seasons and tripled in the last 30 seasons mainly due to the expansion of dairy herds into the South Island (NZ).

1.1.1.1 *Physiology*

There are three primary bovine dairy cattle breeds in New Zealand the Holstein-Friesian, Jersey and Ayrshire. Cross-breeding between the main breeds allows farmers to customise the herd breed to more favourable qualities for their particular region of the New Zealand environment. In particular, New Zealand farmers favour high milk solid production, fertile and easy calving due to the condensed calving period, and medium-sized body structure to minimise leg and foot problems caused from travelling to and from the paddocks and milking shed (Scrimgeour).

1.1.1.2 *Economics*

The milk harvested from the cows is sold to dairy companies for further processing; commonly the nearest milk processing plant is selected. The main milk processing company in New Zealand is Fonterra, the largest co-operative in New Zealand. Smaller dairy companies are Westland Milk Products, Open Country Dairy, Tatua, Synlait, Oceania, Miraka. The milk is sold to the dairy company at a farmgate milk price and is based on the weight of the milk solids (MS) of the milk sold (typically represented as \$/kg MS). The farm gate milk price is dependent on the international market and results in farmgate milk price volatility. In recent years the farmgate milk price Fonterra have been volatile, hitting a record high of \$8.40/kg MS in the 2013/2014 season, then dipping to \$4.40/kg MS in the 2014/2015 season, and subsequently deteriorating to \$3.90/kg MS in the 2015/2016 season. The Dairy NZ's estimated break-even farmgate milk price for farmers is \$5.05kg MS (Gray).

The dairy goods export sector is the leading export sector in New Zealand with the dairy export growth averaging 7.2% per year over the past 26 years. The over 2010-2016 period the average dairy export revenue had been \$14.4 billion, and in the year to March 2016, the dairy export sector was at \$13.6 billion while enduring the drop in the international milk price (John Ballingall).

Dairy is also a significant industry in New Zealand, employing large numbers of people especially in the rural regions of New Zealand. The New Zealand dairy sector employs over 40,000 workers, 27,500 on farm and 13,000 in dairy processing. Additionally, the dairy industry produces 3.5% (\$7.8 billion) of

the GDP (gross domestic product) in New Zealand primarily based from dairy farming (\$5.96 billion) and dairy processing (\$1.88 billion) (John Ballingall).

1.1.1.3 *Environmental*

Currently, in New Zealand, there is controversy relating to the impact dairy farming has on the environment. Environmentalists claim that the intensification of the dairy industry has an impact on the environment relating to the use of irrigation and waterway degradation. (Young)

The use of irrigators in the dairy industry applies water to the property increasing the fertility of the soil, allowing dairy farmers to cultivate feed crops with a higher nutritional value, or to increase the growth of pasture increasing the capability of the land to sustain higher stocking rates. A resource consent from the regional authority is required for the extraction of water from rivers or aquifers for commercial irrigation. The current government proposed a water tax or royalty to be placed on water used for irrigation of 'one or two cents' per 1000 litres. Approximately 2,000 of the 12,000 dairy farms in New Zealand use irrigation. However, irrigation accounts for 97% of all water used on farms in New Zealand. The introduction of the water tax would primarily affect dairy farms that irrigate as they account for a vast majority of the water usage. (NZ).

There are concerns about the impact of irrigation on the environment, primarily nitrate leaching and contamination. Nitrate losses on irrigated land used for vegetable production are generally higher than irrigated dairy properties. However, due to the prominence of the dairy in New Zealand, dairying is primarily blamed. Studies at Lincoln University on the effects of irrigation found that the types of irrigation used affected the nitrate leaching losses with spray irrigators producing lower nitrate leaching losses than flood irrigation. Additionally, that if correctly applied, irrigation can reduce nitrate losses by increasing pasture growth and nitrogen uptake (Heiler).

Another environmental concern supplementary to the use of irrigation and nitrate leaching is the direct contamination of waterways, with the primary concern of cows defecating into or near watercourses, contaminating waterways with sediment, phosphorous, nitrogen and e-coli. Dairy farmers have nearly completed the construction of structures to restrict access to the waterways from the cows by fencing off watercourses and bridging waterway stock crossings are nearing completion (Mackle). Riparian planting the fenced off watercourses is the next course of action to benefit the environment, with the aim of the planting to filter sediment and nutrients before they enter waterways and prevent land erosion near waterways (DairyNZ).

1.1.2 *Sheep (Ovine)*

Annual worldwide production of fresh sheep milk is over 10 million tonnes (10,122,522 tonnes) which is 1.6% of the fresh cow milk production (Griffiths). New Zealand sheep farming industry had played a significant part in farming in New Zealand, primarily for the sale of wool and meat. The national sheep flock peaked in 1982, at 70.3 million and declined due to reductions in profits and government subsidies (Manch). There were a few milking flocks in New Zealand in the late 1970's using local breeds achieving up to 140 litres per ewe, however, ceased after a few seasons due to marketing difficulties (Graham Butcher). The sheep milking breed East Friesian was introduced to New Zealand from Sweden in December 1992 to increase sheep milk production in New Zealand (ALLISON).

Continuing from the introduction of the dairy breeds to New Zealand, a review of the sheep milk industry at the 2015 Sheep Milk conference to New Zealand there were five existing sheep milk dairies operations and three developing ventures (SW Peterson). The sheep milking industry has grown significantly since, and a sheep dairy operation has featured recently on the television show Country Calendar (TVNZ). According to Griffiths, the sheep milk industry is expected to be a billion dollar industry by 2025 (Griffiths).

1.1.2.1 *Physiology*

There are breeds of farmed sheep in New Zealand predominantly developed for meat and wool production. Encyclopædia Britannica and Te-Ara Encyclopaedia give a good outline and description of the standard sheep breeds in New Zealand listed in Table 1.

Table 1- Common sheep breeds of New Zealand

Breed	Breed Qualities
Merino	The usual breeding trend developed by merino breeders is to develop a medium size sheep with good mutton conformation. Folds in the skin increase the surface area of wool growth increasing the volume of wool of high-quality fine crimped wool produced. Merinos are crossed with other breeds due to their qualities of wool quality and hardiness and has served as a foundation stock for many useful breeds of sheep (Britannica ; Peden).
Corriedale	Wool produced is long and medium-to-fine, with crimp and is used in the worsted market. Bred for the meat and wool trade, with high fertility and ability of the lambs to mature early to produce a well-muscled carcass (Peden).
Halfbred	Bred to produce merino's high-quality wool and environmental hardiness, while increasing the breed's ability of lamb production and carcass conformation for the meat trade (Peden).
New Zealand Romney	A predominant breed that makes up 68% of the national flock (over 25 million sheep). The breed produces a heavy fleece used in the production of carpets, furnishings and knitting yarns. Suited for high rainfall and heavy soils and has high resistance to foot rot (Peden).
Perendale	Bred to be more fertile, hardier than the Romney requiring less shepherding best suited for the North Island and wet areas of the South Island (Peden)
Border Leicester	Generally, are crossbred with other breeds to increase the fertility of the offspring due to its fecund and mothering qualities. Wool produced is long and lustrous (Sheep)
Coopworth	A crossbreed between the Romney and the Border Leicester produced by Ian Coop. Suited to the wet environments similar to the Romney and high fertility from the Border Leicester the Coopworth is more productive than the Romney on wetter lowlands (Peden).

Butcher details the critical factor for the renewal of the interest in sheep milking was the release of the East Friesian genetics into New Zealand increasing the milking yield (Graham Butcher). Additionally, the continued development of the ovine dairy in New Zealand is primarily based on the import of milking breed genetics into New Zealand. Due to genetic traits of the sheep milking breeds to maximise production in environmental conditions where the breed was developed, the common sheep milking breeds developed overseas are not ideally suited for standard New Zealand conditions. As a result, additional consideration is required to either, provide conditions that match the milking breeds' original environmental conditions or interbreed with New Zealand sheep breeds that are well suited for New Zealand conditions to develop the sheep for New Zealand conditions and environment – such as the Dairymeade. Providing environmental conditions to suit milking breeds in New Zealand may require the construction of facilities to house the sheep out of the weather, or provide additional

nutritionally dense feed required to produce large amounts of milk. Interbreeding with New Zealand breeds requires the investigation of the heritability of qualities aiming to retain the milk production qualities while introducing hardiness to the New Zealand environment. The ovine dairy breeds are detailed in Table 2

Table 2 - Milking sheep breeds

Breed	Breed Qualities
Lacaune	High milk production was the directive of the breeders in France involving milk recording and progeny testing of sires to base their breeding selections to maximise the milk production. The result was an increase of milk production from 80 litres to 270 litres per season in approximately 30 years and measured over the milking period of 165 days excluding the suckling phase (Griffiths).
Awassi	Developed in the Middle East the breed is a fat tail type producing high-quality meat. The average Awassi can produce over 300 litres in a 210-day lactation, and the milk produced is high in butter fats. Outstanding ewes can produce over 750 litres. Low fertility (120-130%). (Griffiths)
East Friesian	One of the best milking sheep in the world with an average production of 450-500 litres in a 220-240 day lactation. However, the milk produced has lower fat and protein content. Additionally, the breed has high fertility. (Griffiths)
Assaf	Assaf is a cross breed of the Awassi and the East Friesian producing a top-quality dairy sheep and mutton producers. Under Israeli conditions involving three lambing's in two years, the annual milk yield is approximately 650 litres (Griffiths).
Dairymeade	Developed at the New Zealand dairy sheep farm Kingsmeade. The breed based on the East Friesian, which was crossbred with of Coopworth and Border Leicester stock in the 1990's to develop the breed to be better suited to New Zealand conditions (Country ; Stuff)

1.1.2.2 Economics

In 1987, the bovine (cow) dairy industry was first claimed to exceed the sheep wool and meat industries as the most important agricultural industry (Manch). Farming sheep in New Zealand commonly create two products for the economy, wool and meat.

In the local area (Canterbury, New Zealand) a report by Boyd assessed the economic viability of two property conversion options in North Canterbury for dairy sheep (Boyd). The assessment concluded that a more extensive property with partial irrigation and potential to develop into a commercial scale is preferential to a smallholding of dry land. A recent thesis by Downie-Melrose modelled different scenarios of operating a sheep-milking farm in Canterbury, New Zealand. The scenarios assessed different lamb weaning and rearing options affecting total milk production, lamb growth and farm labour requirements. The profitability of the lamb rearing regime and associated milking operation is based on the intensity of the farming system and the availability of resources and labour (Downie-Melrose).

1.1.2.3 Environmental

A study into the effluent management on a dairy sheep farm from AgResearch investigated three case study dairy sheep farms and compared the effluent nutrient concentrations between sheep, cow and goat dairies (N Watkins,b). The results of the study found that the mean nutrient concentrations in sheep dairies were lower than the values reported for the dairy cow and goat effluents. Table 3 lists the concentrations of the nutrients in the effluent of various dairies found in the study.

Table 3 - Nutrient concentrations of dairy effluent of sheep cow and goat

Nutrient	Sheep ^(N Watkins)	Cow ^(Chris Smith)	Goat ^(Chris Smith)
Solids [% Dry Matter]	0.54	0.9	1.4
Nitrogen [kg/m ³]	0.220	0.45	0.21
Phosphorous [kg/m ³]	0.032	0.07	0.06
Potassium [kg/m ³]	0.150	0.37	0.15
Sulphur [kg/m ³]	0.022	0.06	0.14

The size difference between the cows and sheep is an associated factor as cows are 10-12 times larger than sheep and therefore a higher nutrient consumption and total nutrient output (Downie-Melrose).

1.1.3 Properties of sheep milk

Sheep milk has different properties than cow milk making it better suited for producing specialty products such as cheese and yoghurt.

1.1.3.1 Chemical/Nutritional

The chemical and nutritional composition of sheep milk differs from cow milk. The average composition of primary nutrients of sheep milk compared to goat, cow and human milk in Table sourced from ('Physico-chemical characteristics of goat and sheep milk').

Table 4 - Chemical and nutritional composition of various types of milk

Composition	Sheep	Goat	Cow	Human
Fat (%)	7.9	3.8	3.6	4.0
Solids-not-fat (%)	12.0	8.9	9.0	8.9
Lactose (%)	4.9	4.1	4.7	6.9
Protein (%)	6.2	3.4	3.2	1.2
Casein (%)	4.2	2.4	2.6	0.4
Albumin, globulin (%)	1.0	0.6	0.6	0.7
Non-protein N (%)	0.8	0.4	0.2	0.5
Ash (%)	0.6	0.8	0.7	0.3
Calories/100ml	105	70	69	68

Reports imply that people that are intolerance and sensitivities to cow milk are not allergic to sheep milk. The reduction in the sensitivity is due to higher concentrations of MCT (medium short-chain fatty acids) in sheep milk which aid in the absorption of lactose (NZSheepmilkco). As a result, people that are allergic to lactose may find that they may be able to consume sheep milk products that are similar to cow milk products without symptoms of intolerance.

1.1.3.2 Physical

The physical properties of sheep milk are similar to that of cow and goat milk. Milk is sensitive to temperature. Sheep milk is more sensitive to temperature than cow milk and when pasteurised at

65°C for 30 minutes roughly 15% of the water-soluble proteins were denatured. Cow milk pasteurised under similar conditions only experienced 2.3% denaturing of the water-soluble proteins (Balthazar et al.). Dairy products are considered as potentially hazardous foods and must be stored at a safe temperature to prevent the growth of food-poisoning bacteria that may be present in the food, from multiplying to dangerous levels. Milk can be stored safely at temperatures less than 5°C. When not kept less than 5°C the temperature of the milk enters the temperature danger zone (between 5°C and 60°C) where the bacteria can readily grow. It is acceptable that the temperature of the milk can enter the temperature danger zone provided that the total exposure length is not exceeding four hours, as it takes more than four hours for the food poisoning bacteria to grow to dangerous levels. (*Temperature control*)

Sheep and goat produce naturally homogenised milk; cows milk, however, requires homogenisation to prevent fat separation and stratification (Wolford). Homogenisation is a high-pressure process that reduces the size of the fat globules to create a more stable emulsion preventing fat separation and fat stratification.

The acidity of sheep milk is higher than that of cows milk, with a maximum acceptable lactic acid level of 0.26% (or pH less than 6.4) compared to the cow lactic acid level of 0.18% ('Physico-chemical characteristics of goat and sheep milk'). The acidity of milk is used as a distinguishing feature of the suitability of the milk as the lactic bacteria produce lactic acid from the lactose in the milk, indicating that other bacteria have had the opportunity to develop as well. The concentration of the lactic acid is correlated to the total bacterial charge. As a result, milk that is high in lactic acid (low pH) is deemed as unsuitable for sale as it is assumed that the milk has a high bacterial charge including the food poisoning bacteria may be in dangerous concentrations (Lenzi).

1.1.4 Uses

Due to the restrictions on the sale of raw milk, the milk is typically sold to a milk processor for processing into pasteurised or other value-added products. Sheep milk has many uses, due to its physical, nutritional and chemical properties, it can be used to create various milk products such as pasteurised milk, yoghurt, cheese, ice cream, and milk powder.

The sheep milk industry is developing and focusing on producing unique high-end products with attributes that are wanted by high-end customers. Focusing on unique products allows the industry to request a premium price for the products rather than being a commodity-driven industry that is wholly dependant on the supply and demand of the product (Lees). Creating value-added products from the milk would be the best approach to develop the sheep milk industry however sheep milk processors would need to be developed concurrently with the sheep milk industry.

1.1.4.1 Raw milk

The raw milk produced on the farm is sold to a milk processor for processing into pasteurised milk or other various milk products. The sale of raw milk to the general public and processors is restricted requiring the approval of the Ministry of Primary Industries and following the associated regulations and requirements (MPI). Additionally, the farmer can feed orphaned lambs with the raw sheep milk before weaning onto the solid feed.

1.1.4.2 Pasteurised milk

Sheep milk can be pasteurised using the standard pasteurising process. The pasteurising process aims to destroy microorganisms by the application of heat over a short period to increase the storage life of the milk. Ultra-high temperature process (UHT) milk pasteurises the milk over an extended period and higher temperature than standard pasteurisation, increasing the shelf storage life and allowing the milk to be stored hermetically at room temperature. The pasteurisation temperature and holding time varies according to intended storage life, or whether sweeteners are added to the dairy material, and the fat content, particle size, of the dairy material. The minimum pasteurisation temperature and holding times are listed in the dairy heat treatment code of practice (Authority). The application of

heat to milk will cause some degradation of the milk quality. As the proteins of sheep milk are more sensitive to heating than cow milk (Balthazar et al.). The denaturing of the proteins can negatively impair the taste and cause separation of the milk. Additives can be added to reduce the heat sensitivity of the milk for heat treatment.

1.1.4.3 *Frozen milk*

Sheep milk unlike cow or goat milk can be stored frozen for extended periods for cheese making for up to a year with no degradation in quality (Griffiths). The freezing of the sheep milk can allow cheese producers to store the milk in a frozen state for extended storage duration of the sheep milk allowing cheese production during the offseason when the sheep are not lactating allowing continuous production of cheese throughout the year.

1.1.4.4 *Other value-added products*

The milk can be processed to create other products with added market value. The added market value is due to the additional time and processing of the milk required to convert the milk into various milk products that are wanted by the local or international markets. Typically milk products have longer storage life than standard raw or pasteurised milk, and adding supplementary niche traits and qualities to the milk, adding to the value.

Milk powder or dried milk can be used to extend the life of the milk. A specified amount of water mixed with the milk powder reconstitutes the milk powder back into the milk. Milk powder can be mixed with additional supplements to create baby milk formula or health supplements. Creating milk powder is an effective method of storing large volumes of milk as the milk powder. For example, the reconstitution of sheep milk from whole sheep milk powder from is undertaken by adding water at a ratio of six parts water to one part whole sheep milk powder. Provided that the milk powder is stored at recommended storage conditions the shelf life of powder is dependent on the packaging. Milk powder is stored in bulk in 25kg lined bags and in smaller volumes in sealed cans. The shelf life of the milk powder is 18 months and 24 months for the 25kg bags and sealed cans respectfully. ('Whole Sheep Milk Powder')

Yoghurt is a cultured milk product that uses specific bacteria (yoghurt cultures) to ferment the milk into yoghurt. The milk is inoculated with yoghurt cultures at a set temperature which converts the lactose in the milk into lactic acid (*Sheep Yogurt*). The lactic acid causes the milk to thicken and become tart, and the additional acidity prevents harmful bacteria from growing and allows the yoghurt to be stored in a sealed, refrigerated container for one to two months (Buddies).

Cheese is a cultured milk product. Distinct types of cheeses require the cheesemaker to use various processes to produce the desired type of cheese. The typical cheese making process separates the two types of protein casein and whey proteins by curdling the milk. Curdling produces curds and whey. Curds are formed in the milk after a starter culture of bacteria is added to the milk converting the lactose in the milk to and/or adding rennin to the milk. The whey is separated from the curds and removed from the process to allow the curds to dry. The curds are then processed to reduce the water content by cutting the curds, adding salt and/or heating. The clumps of curd are pressed into moulds and left to dry further. The curds are aged in a stable environment until they are mature which is dependent on the type of cheese produced. Additions of moulds or cultures are added to alter the flavour and characteristics of the cheese to produce a niche product. (Bennett ; *The Process Cheese Making 1,2,3*)

Ice cream is a frozen milk product that is produced by mixing air into sweetened milk at below freezing temperatures. The sweetened milk is continuously agitated to contribute to the mouthfeel of the ice cream by reducing the size of the ice crystals that are formed as it is frozen. Sweeteners are added to the milk to sweeten and lower the freezing point of the ice cream and allowing some water to remain unfrozen. This decreases the viscosity and allows the ice cream to be scooped. The fat solids concentration of milk contributes to the creaminess of the ice cream, while the non-fat solids

contribute to the texture and the amount of air that is incorporated within the ice cream. (*Ice Cream Production*)

1.2 Milking

The milking of animals is a complicated process involving the interaction between the milking systems, plant designs, and associated systems that allow animal milking in a safe and timely manner. Milking systems must conform to food safety practices, environmental limitations, animal behaviours and animal physiology.

1.2.1 Milking systems

The milking system compliance is typically achieved by conforming to the outline design of milking systems in the codes of practice for dairy plant design. As a result, the plant design and associated milking equipment for most milking sheds are reasonably standard. However, particular variations to the design are allowed in the code of practice, allowing for the personal requirements of the operator, farmer, and animal milked provided that they meet the code of practice for milking or is an accepted modification.

1.2.1.1 Code of practice

The New Zealand code of practice for the design and operation of farm dairies (NZCP1) and discussions with technicians at Read Industrial Ltd (Rangiora, New Zealand) gave insight to how to best select componentry and design the portable sheep milking plant.

To allow a mobile sheep milking plant to operate and produce saleable milk modifications were required to NZCP1. NZCP1 provides regulations and guidelines encompassing all types of dairies in the dairy industry including dairy cows, sheep and goats. However, the stipulations within NZCP1 are predominantly appropriate for the milking dairy cows in a dairy shed of permanent construction, as this is the most common type of dairy in New Zealand. As a result, the NZCP1 is not fully appropriate for a transportable ovine dairy plant. Hence, modifications to a few stipulations in within the NZCP1 were made and approved by the Ministry of Primary Industries for the 16-unit single aside plant. ('Operational Code: NZCP1: Design and Operation of Farm Dairies')

1.2.1.2 Milking equipment

The design of milking equipment requires the designing of the associated systems such as milking platform, milking system, storage requirements, required resources, procedures and the use of supplementary feed. The fundamentals of the milking equipment design require the assessment of the suitability of the milking equipment for effective and efficient milking including the extraction and storage of the milk as well as the required resources, procedures and practices used on conventional milking equipment.

1.2.1.2.1 Milking system

The equipment used to extract the milk is illustrated in Figure 1.

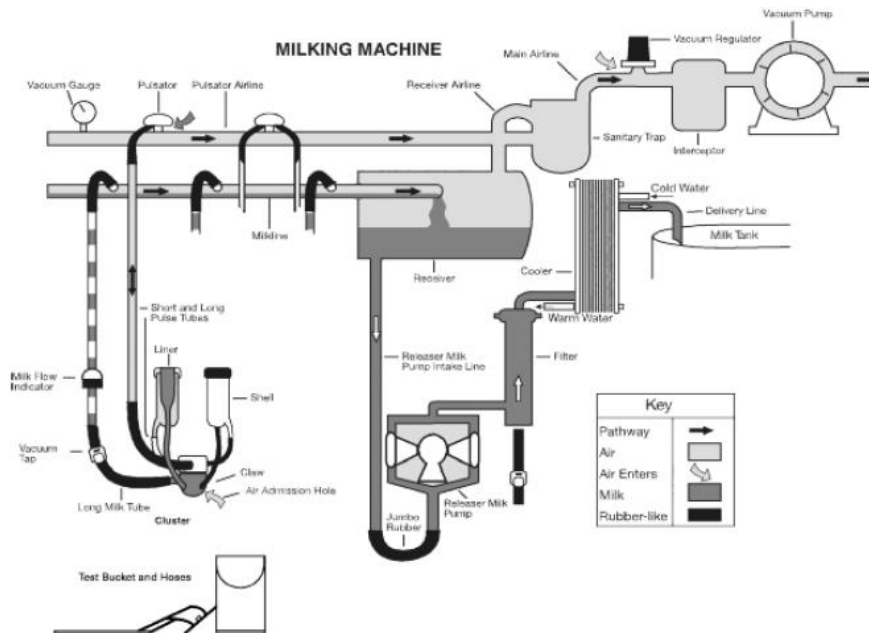

Figure 1 - Milking Machine System Diagram (Accessed from NZCP1('Operational Code: NZCP1: Design and Operation of Farm Dairies'))

There are three processes that the systems use to obtain the milk from the animal these include extraction, collection and pre-processing of the milk.

Milk extraction

The milk extraction system requires the vacuum pump to produce a vacuum within the airlines, milk lines and receiver tank. Pulsators produce a cyclic vacuum pressure in the pulse tubes and the exterior of the cup liner and the shell producing a milking motion in the cup. The cups are placed on the teats and held on to the udder by a vacuum seal produced between the teat/udder and the atmosphere. The milk extracted from the teat is drawn into the interior of the cup liner, into the claw before flowing into the milktube and subsequently into the milklines by the pressure difference created by the vacuum. The linkages (commonly rubber hoses) between the cluster and the remainder of the milking system are required to be flexible allowing the cluster to be removed and placed onto the animal with minimal effort.

Milk collection

The milk is then sucked through the milklines and is collected in the receiver tank allowing initial separation between the milk and vacuum. The milk settles to the bottom of the receiver can and is pumped using the milk pump for the pre-processing operations. The vacuum air is drawn through the receiver airline and into the sanitary trap. Any foreign material and milk drawn from the pulsator airline, or the receiver airline into the sanitary trap is separated allowing only clean air to enter the vacuum pump.

Milk pre-processing

The milk pumped from the receiver tank is forced through a filter to extract any foreign material from the milk before it enters the heat exchanger (cooler) for pre-cooling. The plate cooler uses cool water to reduce the temperature of the milk to 18°C or lower ('Operational Code: NZCP1: Design and Operation of Farm Dairies').

1.1.1.1.1. Milk storage

Milk must be stored at low temperatures to prevent the growth of bacteria. NZCP1 states that "Raw milk must:

- a) be cooled to 10°C or below within four hours of the commencement of milking; and

- b) be cooled to 6°C or below within the sooner of:
 - a. six hours from the commencement of milking, or
 - b. two hours from the completion of milking; and
- c) be held at or below 6°C without freezing until collection or the next milking; and
- d) must not exceed 10°C during subsequent milkings.” (‘Operational Code: NZCP1: Design and Operation of Farm Dairies’)

Compliance with the cooling standard is a minimum requirement for the storage of the milk for further processing. If the milk cooling is not compliant to NZCP1 it must be indicated as not fit for consumption and disposed of appropriately. (‘Operational Code: NZCP1: Design and Operation of Farm Dairies’)

1.2.1.2.2 Essential resources

For the operation of the milking system, the bare minimum required resources are rotary motion and water. The pumps of the system typically use rotary motion provided by an electric motor, although a combustion engine can be used to power directly. The cleaning operations necessary to keep the plant in a sanitary state require water, generally provided by a bore or town supply. However, tanks are used to store and heat the water used for the hot washes.

1.2.1.2.3 Milking Procedures

Procedures for milking aim to minimise the downtime of the milking system to complete required operations in a safe and hygienic manner. For example, the plant can allow for slow milking sheep to milk out, and thus the logistics of this approach may require the milking machinery not to be entirely utilised, decreasing the milking plant efficiency and lengthen the required time taken to milk. Conversely, the operator may choose to prematurely halt milking of the animals to ensure maximum plant efficiency. Prematurely halting milking may result in a knock-on effect to animals that milk out at a slower rate relative to its peers. Standard practices such as MaxT (maximum milking time duration) and milking platform designs such as the herringbone and rotary aim to minimise the downtime and increase efficiency (NZ). Multiple activity charts are used to analyse the efficiency of the milking plant and outline the distribution of time that the milking procedures take to complete (D N Akam).

Typical food safety milking procedures are common to all types of milking and disclosed in a ‘work manual’ as part of the risk management programme for food safety.

Pre-milking

Generally, milking animals are herded from the paddock and down raceways to the milking shed for milking. The milking times of the animals are dependent on the animals’ ability to produce milk, as well as the time the milk tanker can collect the milk and milking system that the farmer wants to use. There are various milking routines such as milking on a daily, twice a day, three times every two days basis, or 16-hour rotation which all have advantages and disadvantages. However, the time of milking should remain consistent to produce a regular routine for the workers and the animals.

During herding, the milking animals are visually assessed to ensure that they are outwardly healthy. Animals that are not outwardly healthy are assessed initially by the farmer to determine the illness and possible cause, and whether a further assessment by a veterinarian for their determination of the illness or to provide treatment to the animal. An identifying marker placed on the sick animals is used to indicate to the operator and farmer that the animal is unsuitable for milking. Records of the ill animal, indicating the ear tag number (or electronic identification number) for identification, the illness and any veterinarian treatment that the animal had completed is essential to ensure that the animal can be identified and removed from the main milking herd and not milked during the milk withholding period. Typically animals that are not suitable for milking are separated from the milking herd until determined by the farmer or vet that the animals are suitable for milking. The suitability of the animal for milking after the animal has been unwell it that the animal should be outwardly healthy and produce wholesome milk fit for consumption, e.g. testing of the milk produced to demonstrate that the udder is not affected by mastitis or other relevant tests. Additionally, records of the medical

treatments are checked to confirm that the animal is not within a milk withholding period. The identifying marker can be crossed out on the animal when confirmation that the animal is suitable to be milked with the main stock, e.g. outwardly healthy, producing demonstrably wholesome milk, not within the veterinarian treatment withholding period.

During milking

Animals with an identifying marker placed on the animal indicating that the milk produced is not fit for consumption are not to be milked by the operator. A crossed out marker indicates to the milker the animal was previously ill and can scrutinise the animal and milk produced more closely to ensure that the wellness of the animal and that the milk produced is wholesome.

Before placing the cups on the udder, the milker manually milks the stock also known as pre-milking. This check aims to identify the wholesomeness of the milk produced by the animal to determine if there are any issues with animal or the produced milk. Testing equipment to identify cases of mastitis are available on hand to test suspected animals. An identifying marker is placed on animals that have tested positive for mastitis or not producing wholesome milk, to ensure that the afflicted animals milk does not enter the milking system.

During wet weather, mud or debris may cover the teats, which must be removed and dried before the animal is milked to avoid the contamination of the milk produced. The cleaning of the teats is done with approved cleaning formulas and procedures to ensure that the teats are clean and dry. Udder wipes are the recommended for the cleaning of the udder in the case of sheep and goats.

Immediately after the completion of milking, the udder is sprayed with teat spray usually iodine based to minimise the risk of infection to the teats (Graham Butcher). Teat spraying can be automated with teat spraying devices however a pressurised hand sprayer is sufficient to apply the test spray solution over the teats.

Post-milking

The Cleaning in place (CIP) wash cleans the milking equipment removing remaining milk as well as residuals from the system. The recommended cleaning system for dairies is a circulation cleaning system which recirculates the wash fluid from the outlet of the milking system (including the vat when no used to hold milk) and back into the clusters ('Operational Code: NZCP1: Design and Operation of Farm Dairies'). The cleaning of the system, cleaning using chemicals specialised for cleaning milking equipment after milkings, commonly, acid wash after the plant is used, and periodical alkali wash. The CIP cleaning regime is determined by a specialist and is recorded in the work manual and on the milking plant cleaning area. The CIP wash usually consists of a rinse, an alkaline or acid wash, the acid wash is done after the plant is used for milking, and the alkali was on a twice weekly basis instead of the acid wash. The acid wash detergent sanitises and removes mineral deposits from the plant. Typically, the acid wash is predominantly comprised of phosphoric acid. The alkali wash detergent removes fat and protein residuals from the plant that the acid washes are unable to remove and is followed by an acid wash to neutralise the pH to avoid degradation of the plant (alkali conditions can damage rubberware). The acid and alkali washes are more effective in cleaning the plant when used with hot water (80°C) however can be used with cold water. Using excessively hot water to clean the plant can lead to decomposition of the detergents and damage to the plant.

When using hot water in a recirculating system, the CIP wash water temperature is hotter than 55°C to avoid redistribution of the milk residuals back onto the milking plant. The temperature is monitored to ensure that the temperature of the CIP wash water exceeds the minimum of 55°C and the wash water is removed from the milking plant before the temperature of the wash water is less than 55°C. Sanitisers are also used after the acid or alkali wash removing bacteria and providing bacterial protection when the plant is not in use between milkings (NZ).

The milking plant and associated systems are washed down with water after milking to remove the effluent and other wastes that have collected on the concrete handling yards, platforms, and equipment to ensure that the plant is in a hygienic state for the following milking. The wastewater enters drains which transfer the effluent and waste fluid into an effluent treatment system to process the fluid before disposal.

When there is a failure to comply with the requirements of the risk management programme or the Animal Products Act 1999, the risk management programme operator is immediately notified. The risk management programme operator then advises the non-compliance to the independent verifier and take immediate corrective actions ('Risk Management Programme (RMP) Template for Farm Dairies - Domestic Supply').

Monthly procedures

The operator inspects the plant to discover any unhygienic, deteriorated or damaged parts of the plant. Unhygienic parts should be cleaned or replaced, and damaged parts serviced, repaired, or replaced as soon as possible. Reasons should be established to determine how the part failed and how to minimise the incidence of the failure. Following the remedy of a failure, more frequent checks should be undertaken to monitor the efficacy of the remedial measures.

Measurements of the animals' milk production may need to be recorded to identify the animals milk production or letdown time for genetic selection to optimise the further genetic traits of milk production of the stock. However, daily milk production data can be collected with automated milk flow meters to give a better indication of the daily milk production of the animals.

Yearly procedures

Checks on the temperature of the milk tank must be completed throughout the year, to ensure that the cooling system can cool the milk within the designated timeframe set out by the NZCP1 section on cooling. The test should be completed to test the refrigerators cooling capacity at the start of the season, to ensure that the system is working, and during a high-temperature summer day to ensure that the system is capable during peak cooling load. ('Operational Code: NZCP1: Design and Operation of Farm Dairies').

In New Zealand, the milking plant is inspected by an MPTA (New Zealand Milking & Pumping Trade Association) verified technician to test the plant and find problems with the plant. The pulsation rate and profile are analysed as well as the condition of the plant to ensure that there are no leaks in the plant, and the plant is maintained to a high standard.

Verification is undertaken on a yearly basis to assess that the dairy is compliant with the risk management programme. The verifier analyses the provisions, procedures, milking plant and milk test results with the risk management programme operator to confirm that the milking plant and processes are compliant. Any non-critical non-conformance issues identified during the verification are resolved immediately. Any critical non-compliance identified is advised to the New Zealand Food Safety Authority, who will undertake the required actions. (Barnao ; 'Risk Management Programme (RMP) Template for Farm Dairies - Domestic Supply')

1.2.2 Plant design

The milking platform should be able to secure the animal temporarily for milking, the yards, milk storage facility and raceways should be simple to construct and flexible to adjust. The aim of maximising comfort and flow to enable the milking of all the animals and clean up within ninety minutes (Arthur Stubbs). The placement of the milking operation is a large part of the design of the milking plant as the placement of the facility should be easily assessable to stock, operators and tankers. The ideal placement of the milking platform is in the raceway allowing vehicle access, water, and allowing the use of gates to separate the sheep after milking. The placement of the milk storage tank will allow access to light vehicles to collect the milk and transport it for further processing. The

sale of the milk domestically requires compliance with NZCP1 or version accepted by MPI. NZCP1 should be adhered to when designing a new farm dairy where possible. Supporting documents such as 'Requirements for the Construction of New Farm Dairies' and 'Dairy Diary' give insight into best practice for milking procedures and are based from NZCP1 (Fonterra ; NZ ; 'Requirements for the Construction of New Farm Dairies'). Amendments to the NZCP1 can be made provided that they have been approved by the Ministry of Primary Industries typically requiring the reasoning for the required amendment.

1.2.2.1 Platform type

Various types of platform design and systems are available to milk animals. The scalability of the platform types to operate at the larger or smaller designs that will suit the desired milking session throughput of the plant. Additionally, the design of the milking platform affects the placement of the associated standard milking systems and slightly varies the operating conditions as a result.

The bucket plants are able to milk an individual or two animals at a time and is better suited to small farms with low stock numbers. Automatic milking plants are able to milk continuously and when the animal wants to be milked and does not require the input of a worker for milking. Portable milking plants are able to be transported on the farm to the animals for milking and can milk small volumes of animals in a cost-effective manner. The walk through, single aside, herringbone and rotary milking plants are larger scale milking systems and can efficiently milk higher numbers of animals in a timely manner while minimising workload for the operators.

1.2.2.1.1 Bucket milking systems

Farmers that want to milk a few animals use bucket milking systems as they are ideal for milking small numbers of animals. Figure 2 shows a Read Industrial portable milking plant. The bucket milking plant is portable and is used in conjunction with a simple platform such as an old walk-through milking plant to secure the animal during milking. The bucket milking systems typically consist of a single or double cluster with what would be the receiver can in a typical milk plant, as a temporary milk tank. The vacuum systems are conventional to the standard dairy system however with a combined interceptor/sanitary trap that is conventional with smaller systems due to size constraints. As the operator is nearby to observe the milk tank to prevent flooding of the vacuum system (overflow of milk, from the receiver can, into the sanitary trap). If the system milk overflows from the receiver can into the sanitary trap, the operator can quickly clean the plant with the use of standard dairy system



Figure 2 - Bucket milking plant

cleaning equipment. Functions that are not completed by the bucket plant are filtering and pre-cooling of the milk, requiring the operator to filter and cool the milk, meeting the required regulations for the end use of the milk.

1.2.2.1.2 Automatic milking systems

Automated milking stalls robotically attach the teat cups to the animal without human intervention. Automatic milking systems allow the animal to be milked voluntarily typically with an incentive such as supplementary feed and uses electronic identification, and sensors to assess the animal health and milk quality (NZ). The benefit of the automatic milking systems is that they can operate endlessly, allowing milking of the animal whenever the animal wants to be milked, maximising the production of milk and minimising the workload of the operator. Fewer milking stalls are required as the animals are milked throughout the day rather than a localised period. Milk collected with these automatic milking systems must be chilled to 6°C before it enters the bulk milk tank at 6°C.

1.2.2.1.3 Portable milking systems

Portable milking systems aim to milk low numbers of animals efficiently. Such plants are used when a conventional bucket plants would lead to an unfeasible milking duration length and the construction of a permanent milking plant would be financially unfeasible. In New Zealand, there is a portable cow milking system 'Milking on the Moove', that is used for milking cows in the Canterbury region and is operated by Glen Herud. Read Industrial Ltd. developed the milking system used for 'Milking on the Moove' portable milking plant. The milk produced is processed into pasteurised milk and is sold to cafes in the local area. (Herud)

1.2.2.1.4 Walkthrough

A walk-through milking platform is a superseded design of milking plant where animals are secured in a stall and milked out using milking equipment. After the animal has completed milking the animal is then able to walk through a gate ahead of the animal, and a new animal takes the place of the previous animal. Herringbone platforms commonly replaced walkthrough milking platforms due to the increased throughput that was capable.

1.2.2.1.5 Single aside

Aligning all of the milking animals in a row, to increase the number of animals that are milked at the same time compared to a bucket milking plant and walk through. The milking is completed in batches, requiring additional time for the animals to walk onto, and off the platform, lengthening the total milking duration, as the milking equipment is not fully utilised throughout milking. The single aside systems commonly include a milking pit similar to the herringbone design.

1.2.2.1.6 Herringbone

The most common dairy platform is a herringbone making up 72% of all milking platforms in New Zealand (John Ballingall). Figure 3 shows a typical herringbone system, with two platforms either side of the milking pit where the operator stands to place the cups on the animal. The platform that the animal is higher than the height of the milking pit that the operator works in, allowing the operator to place the cups on the animal at an appropriate ergonomic height.



Figure 3 - Herringbone milking plant

The herringbone design uses two single side platforms placed on either side of the operator, allowing the milking of one side of the herringbone, while at the other side of the herringbone the milked animals unloaded and animals loaded ready for milking. The herringbone milking system mounts the clusters on a highline above the milking pit allowing the operator to alternate between either side of the milking pit, so the herringbone design uses only half the number of clusters compared to the number of stalls in the milking shed. This optimisation, compared to the single side system, decreases cluster downtime, and associated milking duration. The optimal operation of the herringbone requires the reduction of the associated with the time when the new animals have walked onto the platform and waiting for milking.

The problems with this design are slow milking units that disrupt the flow by preventing one row from exiting as the slow milking unit is being milked out. Application of MaxT procedures can reduce the slow milking problem, as it limits the maximum milking time the unit can prevent the row to exit.

1.2.2.1.7 Rotary

The rotary design is capable of milking large numbers of animal efficiently and although they make up 27% of cow milking sheds the, 44% of the national flock of cows is milked using rotary platforms. Although rotary systems are more expensive than herringbones, their efficiency and effectiveness in milking large numbers of animals make them cost-effective for milking large numbers of animals (NZ).

Animals walk onto to the milking stall on the rotating platform from the onramp and secured into the stall by a bail strap. The operator near the rotary entrance then places the cups on the animals. The animals are moved on the rotary platform animals and are milked out; the cups are then removed and then the animals walk onto the off-ramp and off the rotary plant. Slow milkers can remain on the platform for another rotation of milking without halting production.

Animal orientation on the platform defines the two main types of rotary plant, with internal (animal facing outwards from the platform, udders facing the internal of the platform) and external (opposite from internal). The animals are required to turn in both designs; on entry to the platform in the case of an internal platform or for egress in the case of an external platform. Internal rotaries allow operators to see all the animals being milked out at a glance. However, internal rotaries require an access way to the internal area as well as sufficient area within the internal rotary area for the operators. The direction of the rotation of the platform, as well as the type of rotary, defines the shape and size of the onramp and off-ramp, as sufficient space is required for the animal to turn around. Most of the milking equipment plant, e.g. clusters, pulsators, milklines, receiver tank, mounted on the rotating plant with a connection to the remainder of the stationary plant via a rotary gland, which can transfer electricity, milk, and vacuum. Figure 4 shows an external rotary plant with the receiver can, milk and airlines under the platform, and the centre gland in the centre.

The rotary design is an optimisation to the herringbone as the units are milked almost continuously, with the operator mainly operating in a single small area placing cups as the units rotate past on the platform. Similar to the herringbone design, the rotary milking platform is higher than where the milking operator places the cups on the animal. Near the entranceway and exit are the conventional areas where the operators work in the shed, some rotary systems place a variable height platform to fine tune the height difference between the platforms, allowing for the variability of operator heights.



Figure 4 - External rotary platform

1.2.3 Milking platform system types and additional systems

1.2.3.1 Highline and lowline

Highline and lowline systems are defined by the height of the placement of the milkline from the animal that is milked. If the milkline placed above the udder, the system is defined as a highline system, and if the milkline is placed below, the system is defined as lowline.

As the highline systems require a slug of milk to flow from the milktubes into the raised milkline requiring a pressure difference and appropriate sizing of the milktube. The pressure difference requires an additional vacuum (lower pressure) which is potentially harmful to the animals as the lower pressure (higher vacuum) adds an extra force on the teats, potentially causing injury to the teats that may lead to mastitis. The standard pressure range for sheep highline or lowline system is 42-44kPa for highline, 38-40kPa for lowline ((MPTA) ; Arthur Stubbs).

1.2.3.2 *Automatic cup removal (ACR)*

Automatic cup removal (ACR) systems are used to automatically remove the cups from the animal when it has completed milking and additionally identify issues during milking that may require the attention of the operator. Rotary milking systems typically are installed with automatic cup removal systems. However, automatic cup removal systems are used for long herringbone platforms to aid in removing the cups when required, reducing the labour workload required to operate the milking plant.

ACR systems commonly used a vacuum or compressed air powered piston ram connected with a flexible connection to the cluster. The ram is then able to remove the cluster from retracting the connection to the cluster removing the cluster from the animal after the animal is milked out or maximum milking time (MaxT) has been achieved (NZ ; NZ). The operation of the ram is controlled, electronically with a flow sensor or mechanically from level action or milk float mechanism to remove the cluster. Additional air cylinders on rotary platforms are installed to lift and lower a bail strap. The bail strap is lowered around the animal when the cups are placed on the animal and elevated when there are no detected issues during the milking of the animal. If any issues are detected with milking during the let-down period such as cluster kick-off, the ACR system retains the animal on a rotary system with the bail strap to be assessed by the operator. Electronic systems use a flashing LED light to communicate to the operator the detected issue during the milking.

The ACR rams have a quick release mechanism that disengages the vacuum pressure on the piston in the vacuum ram and therefore the ram discharges rope for the operator to place the cluster on the animal. The quick release mechanism is activated when the weight of the cluster is supported and lifted a small distance. However, if unprotected any dislodgement of the cluster or milk tube may be accidentally trigger the quick release mechanism and the cluster will drop to the platform and may become entrapped or trampled damaging the cluster. Typically, milking plants have teardrops or other structure to protect the cluster from being accidentally dislodged.

1.2.3.3 *Animal identification system*

Animal identification systems use the animal's electronic identifiers commonly electronic ear tags (EID). The animal identification system can be used with milk production monitors and automatic feed systems, to record data on the milk production and distributed additional feed, as well as determining the amount of additional feed to dispense.

1.2.3.4 *Milk production monitor*

A flow meter and animal identification system are used to identify the milk production of the animals. The records of the milk production can be used to determine optimal breeding animals for milk production.

1.2.3.5 *Feed systems*

Automatic feed systems are used to provide additional nutritional support for the animal, as well as providing an incentive to let down. Automatic feed systems are commonly paired with an animal identification system to dispense a pre-determined amount of feed for the animal.

1.2.4 *Unique ovine characteristics*

The milking of sheep differs from that of cows. Hence, the designs of the sheep milking systems are distinct from cow milking systems. The fundamental areas of difference between cows and sheep are physiological and behavioural.

1.2.4.1 *Physiology*

The size difference between the cows and sheep is an associated factor as cows are 10-12 times larger than sheep by mass (Downie-Melrose). However, sheep can milk out quickly, usually less than 90 seconds (Arthur Stubbs ; Graham Butcher). Sheep are capable of producing a milk flow rate of two litres per minute, which is comparable to the milk flow rate of cows (Arthur Stubbs).

The udder shape of a cow's udder and sheep udder differ. Cows have two pairs of mammary glands while sheep have only one pair. As a result, sheep have two teats while cows have four. Different configurations of sheep udders and the placement of the teats affect the susceptibility to cluster kick off and mastitis. One example of this is the angle of the teat on the udder, if the teats are at a high angle the udder does not fully milk empty and the clusters are easily kicked off during milking. If the teats are at a low angle they may come in contact with the ground which may introduce bacteria and cause mastitis (Whatford). Milking length and udder shape and configuration are hereditary. Dairy sheep genetics will be developed by farmers to optimise the milk ability of the sheep.

Milking equipment for sheep, is fit to typical udder configuration to prevent the sheep from kicking the cluster off. Vacuum and pulsation standards for the sheep milking equipment differs from cows to account for the difference in anatomy. Contrary to standard dairy regulations, the ovine regulations are considered as guidelines due to the lack of experimental evidence for optimal sheep milking methods in New Zealand ((MPTA)).

1.2.4.2 *Behavioural*

The handling temperament of sheep is based on the flight zone of the sheep. The flight zone surrounds the animal, and the size of the flight zone is dependent on the how much human contact and the gentle handling the animal has had recently. As dairy sheep are in regular contact with the farmer, the flight zone is smaller than the common meat/wool sheep of New Zealand, which under standard practices have minimal contact with the farmer.

1.3 TRIZ design

All factors described in sections 1.1 and 1.2 need to be synthesised to develop the proposed milking platform. This highly complex series of requirements and optimisation criteria require a rigid design methodology to ensure that none of the factors described earlier are overlooked in the final design. The optimisation of the design of the milking platform with TRIZ methodology can aid the development of designed systems. TRIZ (also identified as TIPS (Theory for Inventive Problem Solving)) is a formal engineering design methodology. TRIZ provides an objective insight into the innovation of solving the identified problems based on prior art, data, and research rather than intuition or trial and error strategies. The design methodology originated in Russia by Genrich Altshuller was created by assessing patented inventions and discovered common traits in the design improvements and created a process that creates ideas on how to solve common problems and contradictions common in engineering design (Arciszewski).

Problems and issues (low ideality design) are analysed to create contradictions. The application of the TRIZ methodology identifies principals of innovative thinking to aid in the production of ideas that can solve the identified issues. The solutions are subsequently reassessed to determine the ideality of the solution.

1.3.1 Abstraction

The separation of the fundamental functions of the overall system into individual components (objects) that act on functions (actions) on other components or mediums (subjects). The object, action, and subjects of the systems or axioms can be used to represent the entire system design using a function list and function map. The abstraction of design into the axiomatic components can be used to identify problematic contradictions that require solving using the TRIZ process, as well as the associated systems that the overall optimisation may affect.

1.3.2 Contradictions

Some objects produce wanted and unwanted products, and in such cases, the system will produce undesired contradictions. For example, an air conditioner would be an example of an engineering object that produces desired products such as conditioned air and unwanted products heated air and noise associated cost of operating the air conditioner. The identified unwanted contradictions are targeted by the TRIZ process to instigate solutions that minimise or remove the contradiction. The

production of inventive solutions enables contradictions to be systematically solved using the TRIZ methodology, rather than using typical engineering trade-offs which cannot solve the contradiction (Savransky). Hence, the systematic approach of the TRIZ methodology should enable more thorough and efficient design solutions than ad-hoc design approaches.

There are two types of contradictions which Altshuller identified: technical and physical. These contradictions are used to identify pairs of characteristics within the system for optimisation. Technical contradictions occur in engineering design in pairs of technical characteristics when the improvement of one characteristic is to the detriment of another characteristic and vice versa. Physical contradictions occur in an engineering system when a physical characteristic, should increase and decrease at the same time. (Arciszewski) For example, increased component strength can often be achieved via using larger sections. However, this will increase the weight or volume of the device, which can be detrimental.

1.3.2.1 *Technical contradictions*

Technical contradictions are represented using technical parameters (also known as formal factors). Thirty-nine technical parameters are used to represent the technical characteristics for evaluation where one parameter is selected for improvement, and the other is maintained. The selected parameters are used to identify the inventive principals, with the aid of an A-matrix, which are best suited to generate ideas to optimally solve the contradiction best.

1.3.2.2 *Physical contradictions*

The solving of physical contradictions requires the investigating the physical characteristic causing the contradiction and solving the physical contradiction by separating the increasing and decreasing physical characteristic by space, time, condition or scale. To aid the production of an idea that solves the contradiction the forty inventive principals are used to separate and minimise the harmful effect of the simultaneous physical characteristic that is increasing and decreasing.

1.3.3 *Technical parameters*

Technical parameters are used to identify the technical contradiction for further analysis and optimisation with TRIZ. There are thirty-nine technical parameters identified in the TRIZ methodology that can be used to represent the technical or physical parameters that make up the contradiction. The abstract representation of the contradiction using the technical parameters allow the application of the TRIZ methodology to physical and technical contradictions within designed systems.

1.3.4 *Inventive principals*

Inventive principals are used to aid the production of ideas and produce an ideal solution to the problem. There are forty inventive principals identified in the TRIZ methodology that can be used to help solve technical and physical contradictions. Inventive principals are identified for technical contradictions with the aid of an A-matrix. The inventive principals can be used to resolve physical contradictions, with each inventive principal able to produce ideas on how to separate the physical characteristic by either space, time, condition or scale.

The A-matrix, also known as the contradiction matrix, is a matrix where the columns are the technical parameters for optimisation and the rows are the existing technical parameters which are to be maintained. To determine the inventive principals that will aid to resolve the contradiction the element within the matrix is selected using the column and row that represents the technical contradiction. The elements within the matrix contains identification numbers that correspond to the inventive principals that could resolve that particular contradiction. The particular A-matrix that was used for the project was sourced from 'TRIZ for Engineers'. (Gadd)

Individual inventive principals are ideally suited to solve particular types of separation (space, time, condition and scale) that are to be used to solve physical contradictions. If a particular type of

separation would suit the design, a list of the inventive principals and their respective suited types of separation they can solve are defined in 'TRIZ for Engineers' (Gadd)

The inventive principals aid the generation of ideas by providing a frame of mind to aid in the development of the design to solve the contradiction. The development of ideas is achieved by discovering similar systems or principals that resolve the current contradiction and therefore producing a solution. The benefit of creatively discovering ideas and principals that are used in similar systems is that the analysis is based on improving and modifying what has been done previously and/or applying principals used in previous designs rather than relying on the standard knowledge and creative capabilities of the designer.

Not all of the inventive principals identified with the A-matrix can solve the identified problem represented by the technical parameters. However, the process of analysing the application of the inventive principals should help with creating optimal solutions to the identified problem.

1.3.5 Ideality

The ideality is a conceptual quasi-formal measure of the suitability of the engineering system and was introduced by Altshuller (Arciszewski). The benefits of the system tend to have associated costs and harms. The ideality of the engineering system is dependent on the associated benefits, costs and harms of the functions completed by the system. Equation 1 represents the calculation of ideality and the relationship between the corresponding components of ideality.

$$Ideality = \frac{\sum benefit}{\sum cost + \sum harm} \quad (1)$$

The equation provides a qualitative measure for ideality of the functions used to compare the benefits of the function with the costs and harms the function introduces. The aim is to optimise ideality by minimising the costs and harms and maximise the benefits produced by the function. Optimal ideality should be the goal while designing engineering systems to produce required functions while minimising the costs and harms that the function produces.

1.3.6 Trimming

Function maps illustrate the functions of the plant and visualise the interactions between components. These illustrations allow the analysis of the system axiomatically, potentially discovering functions or interactions between components that are unwanted, harmful or unnecessary. Such unwanted elements that may not be identified with a process diagram or visual inspection. The trimming process is listed in TRIZ for Engineers by Gadd (Gadd). The subjects, functions, and objects identified in the function map are trimmed after completing a series of flowchart questions about the necessity of the object, action or subject. The trimming flowchart is shown in Figure 5.

The main components of systems that require trimming (also listed in Figure 5) include components (objects and actions) that are complicated without reason, are placed far from the subject it is acting on, inherently costly to operate, or excessive harmful actions.

The trimming process aids in identifying areas for improvement supplementary to standard inspections. Although trimming is not inherently part of the TRIZ methodology, its use in design optimisation in part with the TRIZ process aids design development and process optimisation. Areas identified using the trimming process for improvement can be modified during the development process. Identifying areas of problematic design is key for the optimisation of the systems in the design process. Problematic designs that are not identified are commonly reproduced in the optimised design reducing the overall improvement.

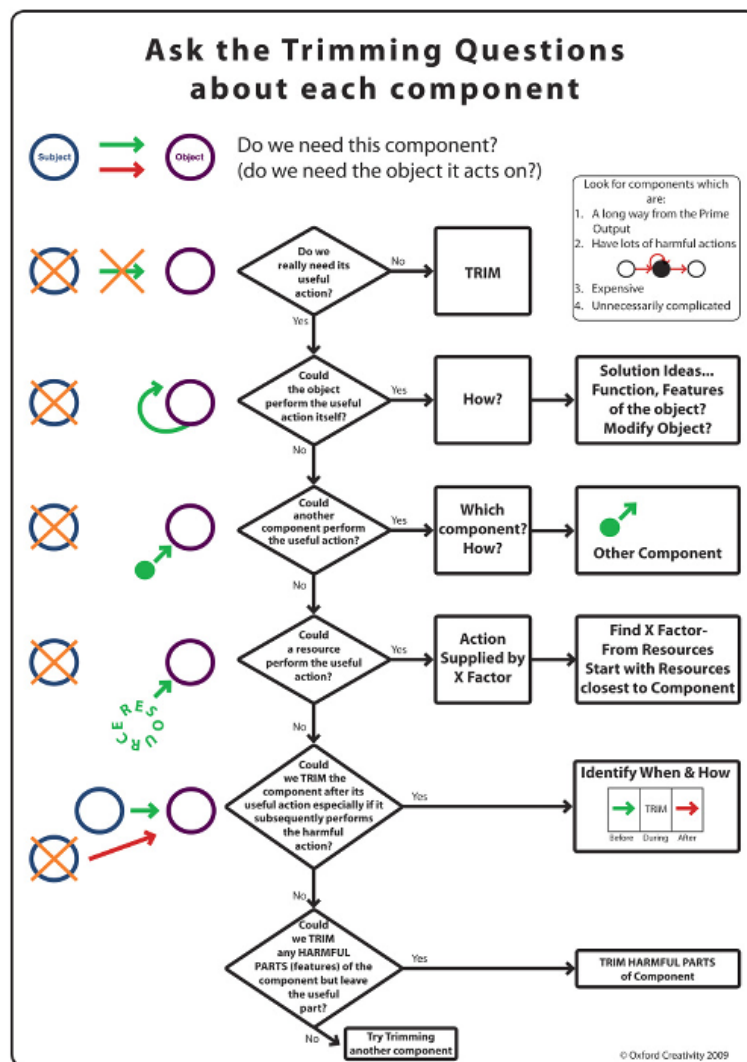

Figure 5 - Trimming of Components and Functions Sourced from TRIZ for Engineers (Gadd)

1.3.7 Worked example

A basic example of a TRIZ optimisation would be an air conditioner in which there are two contradictions. A technical contradiction would be the temperature of the cool air and the noise that is produced from the system. The cooled air production with concurrent waste air stream of heated air is a physical contradiction.

The technical contradiction can be defined by declaring the quantity of benefit (cool air production) and the object generated harmful factor (noise). The inventive principals recommended by the A-matrix to solve the contradiction include, local quality, parameter change, composite materials and inert environment. Using the inventive principals the following ideas listed in Table 5 were produced that could potentially solve the contradiction.

Table 5 - Inventive principals and produced ideas for worked example

Inventive Principal	Ideas Produced
Local Quality	<ul style="list-style-type: none"> • Optimise heat exchanger fin design to maximise heat transfer at lower cooling fan speeds • Variable fan speed control • Operate system at alternate times when the noise would not cause least harm <ul style="list-style-type: none"> ○ Do not operate air conditioner during the early hours of the morning at full speed unless specified ○ Only operate air conditioner when there is a person occupying the room ○ Only operate the air conditioner when there is nobody occupying the room
Parameter change	<ul style="list-style-type: none"> • Instead of using air as a heat sink for the air conditioner, water could be used. • Remain at constant cooling load however alter the volume of air that is cooled and associated temperature of the cooled air to a more suitable system
Composite materials	<ul style="list-style-type: none"> • Use alternate cooling fan or heat exchanger material to one that produces less vibration and noise • Insulating fluid lines used to transfer fluids in the heat pump to retain temperature of fluids, increasing efficiency of heat pump and reducing the requirement of the cooling fan to operate
Inert environment	<ul style="list-style-type: none"> • Using water to as a heat sink for the air conditioner, same as parameter change • Encase air conditioner in a room with noise supressing materials to reduce the noise that is produced while retaining sufficient air flow for efficient operation

The ideas that are generated using this TRIZ process could be produced using traditional idea generation methods such as brainstorming. However, the TRIZ process accelerates the process by localising the idea generation to the specified inventive principals. Although not an exhaustive list of ideas, the localisation that is used when using the selected inventive principals reduces the duration of idea production.

The physical contradiction of the hot and cool airstreams can equally be considered using the TRIZ methodology. The four types of separation that can be used include separation by: space, time, condition and scale. A basic analysis on how to separate and solve the physical contradiction is in Table 6.

Table 6 - Separation type and generated ideas for worked example

Separation Type	Ideas Generated
Space	<ul style="list-style-type: none"> • Operate the heat exhaust to another environment • Utilise the waste heat stream for another purpose
Time	<ul style="list-style-type: none"> • Use thermal storage to allow the plant to operate at different times when required
Condition	<ul style="list-style-type: none"> • Use thermal storage to allow the plant to operate at specified conditions when required
Scale	<ul style="list-style-type: none"> • Produce a small area to cool while heating the remainder of the room

Commonly, air conditioning systems have an outdoor unit, which exhausts the heated air to the external environment separating the heated and cooled air by space.

2 Investigation

2.1 Development of current prototype

Ian MacDonald created the concept of the original system as a method of allowing strategic entry into the sheep milking industry, with the use of a resalable asset. The portable milking trailer increases the accessibility of the milking plant to the stock, compared to traditional milking sheds reducing the time for the stock to travel to and from the milking platform. The portable milking platform additionally can transport the milk temporarily in the rear of the vehicle in a cooling storage vat.

2.1.1 Initial prototype

The development of the initial prototype portable sheep milking system was designed and constructed by Craig Campbell at Read Industrial Ltd. The milking platform was constructed on a traditional trailer frame and was able to milk eight sheep at a time.

2.1.1.1 Platform design

The initial prototype platform was an 8-unit single line parlour. The system used Prattley Cascade gates, to secure the sheep during the milking process. The quick exit system was operated by hand using a lever allowing the sheep to walk out and down the down ramp.

2.1.1.2 Capabilities and issues

Harvested milk was cooled using a plate cooler using pre-chilled water and pumped into a vat within a refrigerated truck at a temperature of 10-12°C. The system used conventional milk cooling equipment that was available at Read Industrial Ltd.

A portable generator mounted on a separate trailer that could not be hitched to the milking plant restricted the transportation of the entire milking system. Furthermore, this ultimately required the movement of two trailers. This causes issues relating to trailer positioning and manoeuvring.

The system used a conventional electric hot water tank which required time for the CIP wash to heat up. A conventional 4" milk filter was used to filter the milk before the cooler. This filter was oversized for the volume of milk that it was filtering and as a result milk was wasted resulting in losses. The filter size was reduced to an older 2" filter that is typically used for very small sheds. This smaller filter reduces milk losses.

2.1.2 Developed prototype

The initial prototype platform was developed further into a 16-unit system with a custom-built trailer by Craig Campbell at Read Industrial Ltd. Parts salvaged from the initial prototype platform and used on the developed prototype. The trailer used the same single aside with quick exit concept, which allowed the operator to be able to efficiently milk with the exception during the loading and unloading of sheep on the platform.

The current portable system in current use is a 16-unit single lane parlour shown in Figure 6



Figure 6 - 16 Signal aside portable sheep milking plant

The operator was able to milk at maximum efficiency for a single aside system as the duration of time that the operator takes to place the cups on the sheep along the platform was the milking duration of the sheep.

2.1.2.1 Capabilities

Function maps illustrate the interactions between system components for the entire portable milking system. Appendix A is a function map of the entire single aside milking system. Figure 7 shows the fundamental milking system analysis a basic function map of the system. Analysis of the function maps provided insight into problematic systems and systems for optimisation.

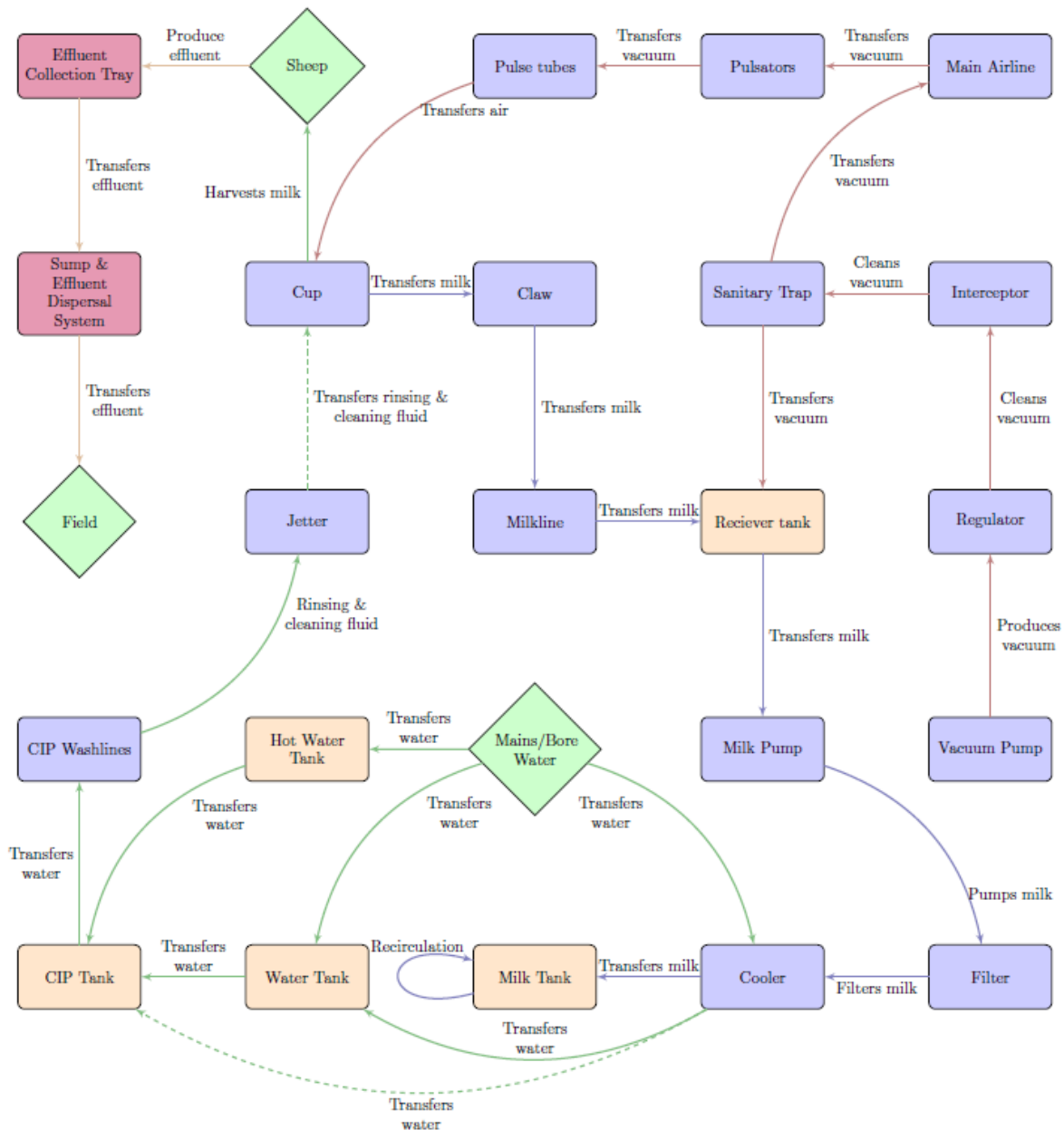

Figure 7 - Fundamental milking system analysis

2.1.2.2 Procedures

The heating of hot water for the second system uses a small fireplace with water back mounted on a portable platform. This system allowed Ian to light the fire to heat the water before milking the sheep.

After the completion of milking, the portable milking system was transported to the hot water system, which had been heated to the required temperature of 80°C.

As the system uses the single aside system, the typical plant inefficiencies that include, waiting for slow milking sheep to milk out and sheep to enter and egress to and from the platform. However due to the increased length of the system compared to the eight single aside system the operator does not have to additionally wait for the sheep to milk out, as the time taken to place the cups on the sheep is approximately equal to the duration of the typical complete sheep milking.

2.2 TRIZ evaluation of current system and implications for system development

The evaluation of the developed prototype using the TRIZ methodology analysed the products and components used in the design identifying the identified problem, the optimisation using the TRIZ methodology, a review of the identified solution. The impact of the application of the identified solutions on the associated systems is completed to ensure that the application of the solution does not create unintended issues.

2.2.1 Production analysis

Production analysis of the platform design and the loading and exit platform. The analysis of these systems was due to their impact on the milking throughput of the system. In particular, improving the throughput was the main objective of the design improvement.

2.2.1.1 Platform design

2.2.1.1.1 Problem

The design goal of the third iteration of milking machine requires the productivity of the milking platform to be maximised by increasing the throughput of the system. To improve the productivity of the milking platform requires the optimisation of the milking efficiency and quantity of sheep milked concurrently.

The inefficient operation of the milking process of the current design is due to operational downtime. During operation of the milking, the milking equipment is inactive as the batch of milked sheep to exit the platform and for the batch of sheep awaiting milking to enter the platform. Additionally, the milking equipment is partially active when a slow milker requires extended time to milk out, as the remainder of the batch have completed milking the bulk of the milking equipment is not in use extending the duration of the milking of the batch, creating an inefficiency. Ideal milking efficiency requires the minimalisation of downtime when the system is inactive or partially active. The area and shape of the trailer constrain the ideality of the design of the milking platform requiring the identifying of an innovative solution to optimise the use of the shape and maximum area required for transportability while retaining the convenience of use.

Technical parameters selected to represent the problem is to increase productivity while retaining the area of the stationary object, shape, and convenience of use. Note: The selection of the technical parameter area of the stationary object instead of the area of the moving object is due to the milking platform is fixed with respect to the trailer.

2.2.1.1.2 Optimisation

The inventive principles identified from the technical parameters listed below in Table 7.

Table 7 - TRIZ Inventive Principals for Optimising the Productivity of the Portable Sheep Milking Plant

	Area of stationary object	Shape	Convenience of use
Productivity	<ul style="list-style-type: none"> • Prior Action • Parameter change • Another dimension • Nested doll 	<ul style="list-style-type: none"> • Spheroidality – Curvature • Prior action 	<ul style="list-style-type: none"> • Segmentation • Replace mechanical system • Nested doll

-
- Discarding and Recovering
 - Composite materials
 - Periodic action
-

The inventive principals were assessed for their suitability for improving the design of the milking platform. The inventive principals that produced suitable appropriate solutions and possibly improve the milking efficiency include:

1. Use of another dimension
2. Spheroidality – Curvature
3. Prior action
4. Segmentation
5. Nested doll

The subsections following detail the inventive principals used to create concepts to improve the design of the milking platform.

Use of another dimension

The use of another dimension optimises the use of a stationary area by assessing the use of space. To optimise the use of space the use of another dimension is used to change the design by assessing the use of adding a dimension, reorientate or use another side of the given. This inventive principle produced two concepts herringbone which is used in industry and the under and over a modification of the herringbone design that is potentially feasible.

Herringbone

The herringbone design is a milking platform design used in industry, as it is a simple milking platform to set up and operate. The design consists of two milking platforms side by side with the operator in the centre. The design is semi-continuous allowing near continuous operation as one lane exit and enters the other lane is milking and as the cups are removed from one side and placed on the sheep on the opposing lane. The milking system can vary between platform designs with some designs only able to milk one lane at a time requiring a high milk line, and some designs able to milk all of the sheep at the same time using a low milk line.

Problems with the design include the consistency of the semi-continuous operation is disturbed by slow milking sheep and wide variation of the milking time of the sheep for optimal process design. In particular, slow milkers disturb the semi-continuous milking as they require extended time to complete milking. The variation in the length of milking disrupts the operating efficiency as the operator has to move erratically along the batch adding additional effort and time to the process. When there are significant variations in the milking time the sheep in the batch complete milking in a different order to the placement of the clusters onto the sheep requiring the operator to remove the clusters in an irregular pattern. As a result, the operator has to move erratically as the clusters require prompt removal when the sheep has completed milking to prevent overmilking.

As New Zealand has a developing dairy sheep industry, the genetics for milk production are evolving the variations in the milking production and length are common, and considerations should be made to minimise the effect of variations in milking efficiency.

Under and over

The 'under and over' system is a variation of the herringbone design where instead of placing the lanes on either side of the operator the lanes are placed above and below. This design is feasible due to the small size of the sheep allowing ergonomically feasible milking. The problems associated with the under and over design are identical to the herringbone system.

Spheroidality – Curvature

The 'spheroidality – curvature' innovative principal optimises the use of space by adding spheroids or curvature to the design and can convert a system from a batch system to a continuous operation system. The inventive principle produced a few designs incorporating the use of a rotary milking platform used in industry.

Rotary

The rotary system is a continuous operation, milking platform that can milk continuously and uses the curvature of the design to maximise the use of space. The sheep walk on one side of the rotating platform and rotate around to the operator who attaches the milking apparatus to the sheep. A rotating platform rotates the sheep around the milking platform as they are milking. Sensors measuring the milk output of the sheep determine when the milking has finished, and an ACR (automatic cup removal) system can be used to remove the milking apparatus from the sheep. The exit ramp placed before the entry ramp allows the sheep to exit from the stall backwards onto the exit ramp and back to pasture.

Due to the design, slow milkers are not problematic as the system allows the sheep to rotate around the platform for a second rotation extending the total milking duration. The system requires the use of an automatic cup removal system if only a single operator operates the system.

The rotary systems require two operators or an ACR system to operate; a single operator cannot add or remove the clusters as the on-ramp, and off-ramp physically obstructs the operator from completing both of the tasks. ACR systems are added to rotary systems as it reduces the operation labour requirement, as an operator is not required to remove the milking clusters. The ACR system additionally removes the cups when required and can be controlled to remove the cups under different conditions such as maximum milking time and minimum milk flow rate.

Segmentation

Segmentation optimises the use of space by dividing the system into segments for assembly and disassembly when required. Segmentation can be used to produce a transportable milking system that requires assembly before use as a milking platform and disassembly when it is needed to be able to be transported. The magnitude of the implementation of the inventive principal segmentation to the design can lead to different concepts with advantages and disadvantages. The two concepts that use this inventive principal are the transportable system and the portable rotary system

Segmentation of individual platforms (rotary)

For a rotary system to be cost-effective, the calculated ideal diameter of the milking platform (4.2m) is much larger than the maximum legal trailer width of 2.55m. For suitability for the milking system to be easily transported, the platform should be able to be stored within the legal maximum width by dividing the platform into segments to fold away during transportation and unpack for use as a milking platform. This system should be able to be set up in a short period and automated to ensure overall, and not just operational, efficiency of the system.

Transportable system (requires assembly and disassembly for use)

The transportable system concept is a system where all of the parts are segmented requiring assembly for use as a milking platform and disassembly for transportation. The transportable system would be ideal for a small milking system however due to the constraints in dealing with the effluent and platform design this is only feasible for farms that are converting to ovine dairy completely that have an existing effluent management system such as a cow dairy plant. With a plant like this, refurbishing the permanent facility would be a cheaper option than having a transportable system.

Prior action

Prior action optimises the production time by completing a set-up action prior to the operation to increase the overall productivity of the system, or productivity during a selected period. As the primary

constraint of the system from a production viewpoint is the throughput and milking ability of the sheep.

Separating slow milkers

Separating the slow milkers from the flock for batch milking system allows them to be milked in the same batch reducing the time waiting for the slow milking sheep evenly distributed within the milking flock.

Nested doll (Systems within systems)

The nested doll inventive principle optimises the use of the volume by placing objects within other objects. The folding of the platforms would allow for the platforms to fold out during operation and fold away during transport.

2.2.1.1.3 Identified Solution

The identified solutions that best solve the throughput issue are listed below.

- Rotary for continuous operation
- Segmentation for space management
- Segmentation of individual platforms

A combination of these identified solutions should produce an ideal solution based on the application of the TRIZ methodology.

2.2.1.1.4 Review

To conclude the critical evaluation of the current platform design and planned solutions will aid in the development and operation of the new portable milking plant optimising the productivity of the system while maintaining area, shape, and convenience of use. Associated systems affected by the redesign have been analysed in Section 2.2.3 ensuring that the associated functions completed by the current platform design are before are managed in the new platform design.

2.2.1.2 Loading and exit platform

2.2.1.2.1 Problem

The problems with the current loading and exit system were that the sheep were treading dirt onto the platform, sheep sliding down the platform, and the force required to operate the quick exit mechanism was quite large.

2.2.1.2.2 Optimisation

TRIZ Technical parameters that best represented the problem was to improve (minimise) the object affected harmful factors while retaining the shape and the device complexity. Due to the development of the platform designs from the original single lane system, there is insufficient area and minimal benefit for adding the quick exit system. As a result, no further optimisation of the quick exit system was undertaken.

The inventive principals that produced solutions include the use of local quality, blessing in disguise, and periodic action. An analysis was completed to develop design ideas to optimise the design using the inventive principals to innovate and research similar designs.

Local quality

Local quality involves changing the shape and scale of the object by changing the structure from uniform to non-uniform or design the components to produce useful functions best suited for the environment. The use of local quality can be used to create a better onramp. This can be done by changing the platform material from a uniform material to a non-uniform material. In particular, the use of walkway sheet could be used to activate the hoof allowing trapped dirt and grass onto the onramp and not the platforms.

Blessing in disguise

Blessing in disguise involves converting a harm into a benefit. As cleaning the platforms, a necessity after milking has occurred, rinsing the dirt and effluent from the platform during operation can be undertaken during milking. The development of the cleaning operation is beneficial as the platform is cleaned during operation minimising the cleaning of the platform after milking and additionally uses excess water from the milk cooling

Periodic action

The inventive principal periodic action involves doing a periodic action instead of a continuous action. The periodic action inventive principle used in conjunction with the blessing in disguise as the water can be used to wash the platform near the exit platform the water will signal to the completion of milking to the sheep and for the sheep to prepare to leave the platform.

2.2.1.2.3 Review

To conclude the critical evaluation of the current loading and exit ramp is not required for a rotary system the quick exit system. However, a turnaround area is required allowing the sheep to back off the rotating platform and subsequently walk down the off-ramp. The effect on the loading distribution of the sheep on the platform is considered in the design of the trailer structure.

2.2.2 Component analysis

Analysis and trimming of components within the system that were identified as problematic design enables the further optimisation of the overall plant. Problematic design was identified via the trimming process in Section 1.3.6 and the function map of the system.

2.2.2.1 Effluent system & CIP system

2.2.2.1.1 Background

A significant requirement on the milking system is the management of the effluent that produced while the sheep are on the milking plant. In New Zealand, the disposal must conform to regulations set out by the regional authorities of New Zealand. Typically, permanently cow milking plants produce large volumes of effluent, requiring the treatment in oxidation ponds before disposal. As outlined in Section 1.1.2.3, the sheep produce effluent with lower nutrient concentrations than cows.

The major factors that affect the amount of effluent that is required for disposal include the number of animals milked, the frequency of the milking and the volume of wash water used to clean the walkways and milking system. Minor factors affecting effluent disposal volumes include the stress levels of the animals during, and precipitation that is collected on the platform. The operator must consider the expected amount of effluent produced on the plant to ensure that the disposal conforms to the regional authority regulations.

The current system conforms to the regulations set out by Environment Canterbury the regional authority for the Canterbury region. However, as the portable rotary plant is able to milk more sheep, more effluent may be produced or the plant may operate in a different regional area with different regulations. Therefore, a more effective effluent management system may be required for the plant to comply with the specific regional authority regulations that the milking plant operates in. As regulations vary between the regional authorities, the disposal volumes and procedures of the current system may not be compliant with the other regional authorities' regulations. Optimisation of the effluent system is required to minimise the volumes of effluent that are required for disposal to reduce possible issues with complying with regulations.

2.2.2.1.2 Problem

The problem with the upgraded system is that the volume of effluent for disposal may exceed allowable limits set out by the regional authority.

2.2.2.1.3 Optimisation

The problem can be represented using the TRIZ technical parameters to optimise the object generated harmful factors while retaining the convenience of use. The optimisation of the object generated harmful factors in this case aims to minimise or remove the harmful factor. The inventive principals identified using the TRIZ A-matrix that would be best suited for solving the technical parameters include, 'taking out' and 'self-service'.

Taking out

Taking out involves modifying the design to remove the harmful feature from the component. Remove the CIP wash water from the effluent and dispose of separately. This solution is not in line with current agricultural practices and may not adhere to the code of practice

Self-service

Adapting the off-ramp and on-ramp design to reduce the amount of dirt tracking onto the platform adheres to the 'self service' inventive principal. Minimising the water required to clean the surface (use easily cleanable surfaces). For rotary systems, it may also be possible to use a water jet to clean the platforms after the sheep has exited periodically to prevent drying out.

2.2.2.1.4 Review

Due to the increase in the size of the plant additional tanks will be required to store the CIP wastewater and effluent separately. The separation of the water reduces the amount of effluent disposed of and appropriate treatment of the CIP wash water before disposal if milking twice a day for 200 days. Appropriate mixing of the CIP wastewater into the effluent tank will allow efficient disposal and planning of the amount of effluent disposed of would be beneficial to ensure compliance with the regulations.

2.2.2.2 Hot water

Trimming removes component due to the additional process required for cleaning required the system to move to a hot water tank for CIP cleaning. To remove this process will save operation time and remove the unnecessary moving of the platform. To replace the system a portable hot water heating solution is required. Portable water heating systems are available for transportable tanks. However, an on-demand system would be preferential due to the system not requiring a tank for storage, insulation to minimise heat loss, and not having to wait for the water to get up to temperature. As the hot water is required for the cleaning process after milking has ceased, the primary demand for the generated electricity is the milk tank refrigeration. An alternative form of energy is preferred to minimise the loading on the generator.

The most optimal solution is the use of a gas califont or similar device to heat the water when necessary as a hot water storage tank will not be required on the platform, and the system is small and requires an LPG tank. The use of a califont also reduces the risk of insufficient (<60°) or excessive temperature from occurring as califont systems can actively control the temperature of the output water stream.

2.3 Component layout

The component layout of the system is based on the ergonomics and optimal systems layout to minimise waste. The ergonomics of the system are required to milk the sheep efficiently with minimal discomfort for the operator. The layout of the systems is based on the optimal placement of the inlets and outlets of the system for ease of use and minimisation of waste.

2.3.1 Ergonomics

The main ergonomic feature of the milking plant for rotary systems is the height of platform relative to the operator height. The operator must be able to access the sheep that are on the platform, requiring accessibility to the udder to wipe dirt if required, inspect for disease and placing the cluster on the udder. This is a repetitive process as it must be completed on all of the sheep that are milked.

As a result, to minimise discomfort of the repetitive action the optimal height of the platform is the height of a standing person's relaxed elbow (vertical height of a person's elbow when arms are in relaxed position). As individual heights vary from person to person, ergonomics is required to determine the optimal height of the platform to conform to the average height of an operator. Additionally, variability of the platform height is required for the fine adjustment of the height, which are available for rotary platforms. Milking pits that are used in permanent plants that allow a short operator to use a pedestal to raise them to a more acceptable height, while requiring that the milking pit be excavated to allow taller operator to operate at an acceptable height. The milking plant has four screw adjustable height stands that are placed on the corners of the trailer that are able to lift the platform off uneven ground and raise the platform up for a taller operator. Shorter operators could use a portable pedestal to stand on or raise a mound to stand on that can be used later when the plant is positioned in the same place on the farm.

2.3.2 Systems layout

The positioning of the systems of the plant is based while it is best suited to best fulfil the purpose of the process and within the space constraints of the system. Unconventional to typical rotary systems the portable milking platform has the vacuum system on the rotating platform, as it removes the required vacuum section of the rotary gland reducing the complexity of the system. The milk pump, filter and cooler is placed on the front of the trailer to reduce the pipe distance to the bulk milk tank

3 Development/Optimisation

3.1 Design criteria

The design is intended for milking flocks of 50 to 350 sheep at a time, on farms with a single flock or milking multiple flocks of dairy sheep. The design of a portable milking platform able to milk on small sheep dairy farms allows the farmer to convert to sheep dairy without the construction of a permanent milking platform. The cost of the construction of the portable plant is small when compared to the construction of the permanent milking machine and associated systems for a small sheep farm. The portable milking plant provides a milking plant that allows the farmers to develop from small sheep milk farm into a medium-sized farm and construct a permanent milking plant when it is required. Additionally, when the portable milking plant is not required the portable plant can be sold and transported to other farms wanting to develop into the dairy sheep industry.

3.2 Manufacturing capabilities of Read Industrial Ltd

This project was completed equally between the mechanical engineering postgraduate offices and at Read Industrial Ltd based in Rangiora, New Zealand who were the clients of the design. They in turn planned to sell the plant to Ian MacDonald. Read Industrial Ltd is an agricultural manufacturer that produces parts and products milking machines, irrigation products for the Canterbury region. Read Industrial Ltd sell products throughout New Zealand and internationally. Read Industrial Ltd is a company that has grown to become a leading manufacturer in New Zealand, continually developing with the agricultural industry over the 95 years of service in Canterbury. Read Industrial Ltd has a team of technicians for the installation of milking plants and systems and routine machine tests, plant upgrades, and the maintenance and servicing of milking machines in the Canterbury region.

The workshop technicians specialise in the manufacturing of the components, and assembly of the speciality agricultural products, and general engineering. At Read Industrial Ltd there are many types of production equipment that are required to manufacture the agriculture products on site. The three main areas of production on site include a foundry, CNC machine shop, and general engineering area.

The foundry is capable of various casting methods including die casting, sand casting and investment casting. Multiple furnaces are available for melting of the broad range of metals for casting including aluminium, brass, stainless steel, irons, and other metals. An aluminium resistance furnace is available to melt large volumes of aluminium, and induction furnaces are used to melt the other metals. The investment casting process can produce a high detail cast product using moulds that are produced by CNC equipment that is available on site.

In the CNC machine shop, there are multiple Okuma CNC milling and turning machines available to agricultural machine parts. CAD/CAM and CNC simulation software are used to ensure that the machines produce the parts to a high standard and operate in an ideal manner. There are two high-speed CNC mills, including a 5-axis mill and 4-axis mill. For CNC turning there are four machines available including, a twin spindle 6-axis CNC turning centre, a twin spindle, twin turret turning centre and two 2-axis CNC lathes.

The general engineering area has general engineering tools and equipment for manufacturing and fabrication of parts and equipment used for agricultural and other industries. Machinery in the general engineering area that would be of use for the construction of a portable milking plant includes but is not limited to, sheet metal forming, pipe bending and welding equipment, as well as machines for cutting, drilling, milling, turning and other typical machine shop tools and equipment. A 1.2m sheet roller, an 80-ton punch and shear, a 3m wide guillotine, and 120-ton press brake are available for sheet work, and an 80-ton pipe roller able to bend pipe up to 4" in diameter. Various types of welding equipment are also available including the standard and specialist MIG, TIG, and ARC.

3.3 System design

The development of the initial design using the TRIZ methodology produced various concepts that were developed and evaluated for their suitability for a portable milking platform for sheep.

3.3.1 Concept development

The initial concepts for the improved platform design used the solutions identified using the TRIZ methodology to solve the throughput issue. The inventive solutions were: rotary (Spheroidality – Curvature) for continuous operation, segmentation for space management and segmentation of platforms. There were four broad concepts developed using principals used in rotary and herringbone platform designs.

3.3.1.1 Herringbone

The efficiency provided with the addition of another lane to the design compared to the original single aside lane was considerable. Two unique initial concepts that could remain within the form factor to remain within limits allowing the system to be transportable and increase productivity were: the side by side, and the under and over. These ideas used the inventive principals segmentation and another dimension to improve the space management and optimise the placement of the platforms within the maximum trailer dimensions while retaining the productivity.

3.3.1.1.1 Side by side

The side by side concept is similar to a conventional herringbone platform. However, due to the size constraints for transportation, the platforms needed to translate outwards to provide enough area for the milking pit that the operator could efficiently operate the milking plant. Figure 8 shows initial sketches of the side by side design.

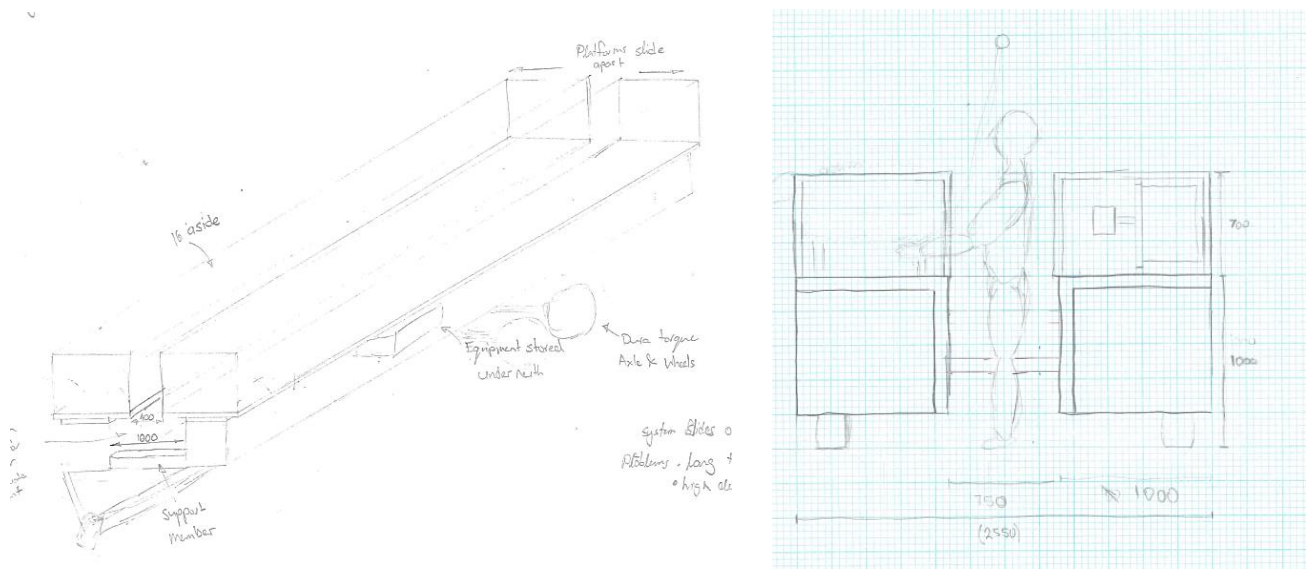

Figure 8 - Side by side concept

3.3.1.1.2 Under and over

Using the principals of the herringbone, the under and over system takes advantage of the dual lane system and the smaller size of the sheep. In particular, a row of platforms place above another row in a tiered system. The under and over system concept sketch is shown in Figure 9.

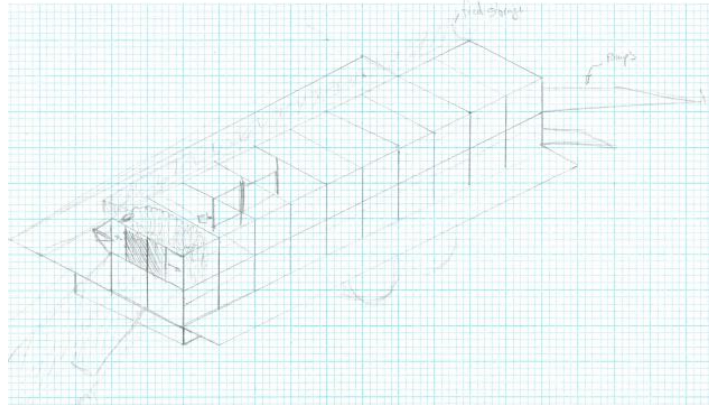

Figure 9 - Under and over concept sketch

3.3.1.2 Rotary

The continuous operation of the rotary platform would improve the milking plant efficiency via increased throughput compared to the single aside as well as the herringbone platform designs. Four initial concepts were defined: taco, track, butterfly, and ferris wheel.

3.3.1.2.1 Taco

The taco design folds two circular segments on the rotating platform upwards to fit within the allowable transportable width. The concept was named taco due to the similarity of the appearance of the design to a hard shell taco. Figure 10 illustrates the folding and placement of systems on the taco design

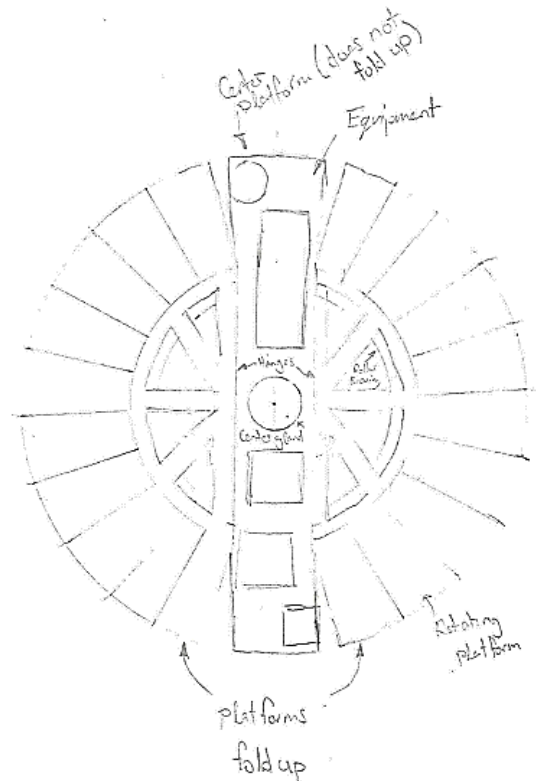
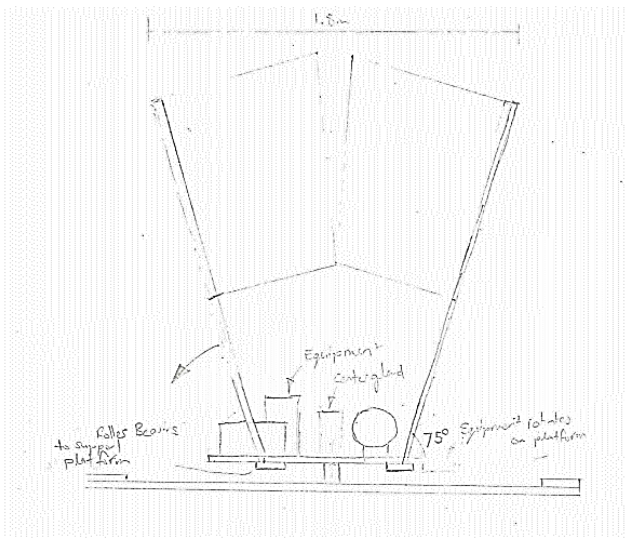

Figure 10 - Taco design concept sketch

3.3.1.2.2 Butterfly

The butterfly design folds the rotating platform along a central line, with the semi-circular platforms lifted within the allowable transportable trailer width. This system differs from the taco design as illustrated in Figure 11.

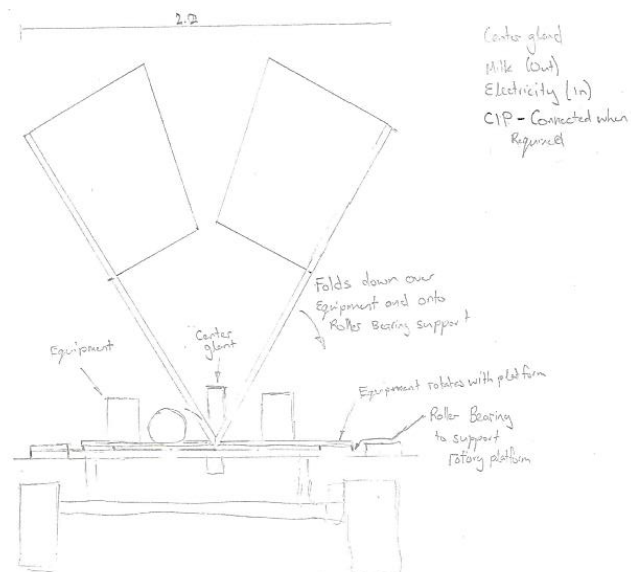

Figure 11 - Butterfly concept sketch

3.3.1.2.3 Track

To remain within the defined transportable trailer width including operation, the milking platform uses a carousel similar to a luggage carousel at an airport. This operates in a rotary manner, however, with the oval track there is no need for an assembly step. The track system would operate similarly to a rotary however it fits within the trailer due to the elongation as shown in Figure 12

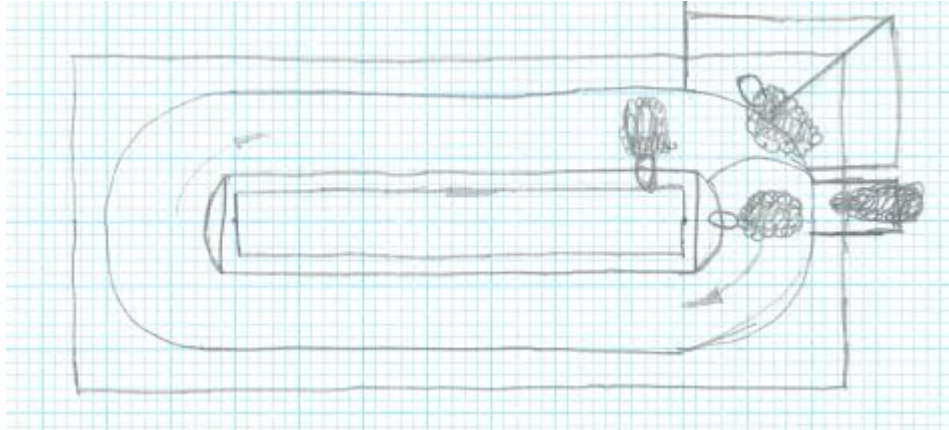

Figure 12 - Track concept sketch

3.3.1.2.4 Ferris wheel

Platforms mounted at the end of spokes of a rotating upright wheel, similar to a Ferris wheel, allowing the milking of the sheep continuously while remaining within the maximum trailer width as shown in Figure 13. These platforms would operate similarly to a herringbone system as the sheep walk along the platforms and find their bail and additionally operate similarly to a rotary system as the process is continuous.

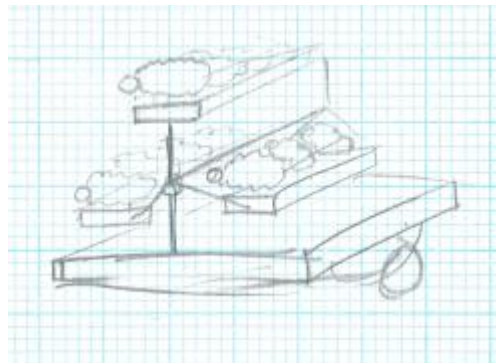

Figure 13 - Ferris wheel concept sketch

3.3.2 Concept evaluation

3.3.2.1 Herringbone

The herringbone platforms are an improvement from the single aside system however due to the size constraints the entry and exit of these systems would be complex. With a general herringbone system, the sheep would walk onto the platform from one side and exit on the other. With the herringbone platform on the trailer, there would be a ramp on the front and rear of the trailer. A ramp at the front of the trailer is problematic as the ramp would have to make a sharp turn to avoid the towing vehicle, which impacts the flow of the sheep onto or off the platform.

3.3.2.1.1 Side by side

The side by side is a conventional dairy design accepted in the dairy industry of New Zealand. The platforms require a sliding mechanism to slide the platform outwards to provide enough room for the operator to milk in the milking pit.

The trailer design would have to minimise the trailer components that intersect the milking pit area while providing adequate support to the platforms and milking system structures while not intersecting the milking pit area. Common trailer designs commonly use transverse support members to hold longitudinal members and preventing warping. In the side by side proposal, the only regions that these support members can be placed are at the front and rear of the trailer. Easy access to the milking area may require the removal of one of the supports as it would be a trip hazard. Additional trailer structures such as the axles will require replacement with half beam axles such as a Duratorque axle

3.3.2.1.2 Under and over

The under and over platform would operate similarly to a herringbone design. However, the tiered system generates some deleterious issues. One of the main issues is the placement of the milkline. The system would have to be either a dedicated highline or lowline system, or have a variable pressure system that is used to convert the vacuum pressure to a highline or lowline system as required. If a dedicated highline or lowline system is used, the length of the milk tubes would add additional weight to the cluster that is supported by the udder. The benefit of the variable pressure system is ambiguous as the clusters are sequentially removed from one animal on the lower platform requiring highline pressure, to an animal on the higher platform ideally requiring lowline pressure or vice versa. Even if the vacuum pressure is lowered or raised before or after the clusters are transferred there would be either excessive pressure difference for the sheep on the upper platforms or insufficient pressure to raise the milk to the highline on the lower platforms during the transfer of the clusters.

The ergonomics of the system are also poor as the operator has to work at two heights. The neutral position of placing the cluster on an animal is the height of the elbows when standing with the arms in a downwards state. Even though sheep are small, the height difference between the platforms would induce an ergonomic cost compared to the side by side platform.

3.3.2.2 Rotary

The area required to milk a reasonable rate of sheep on a rotary platform means that the platforms must be folded away for the system to be transportable on New Zealand roads. The folding of the rotating platform introduces problems to the design of the plant, such as the placement of the milkline and airlines, rotary platform rail, and the intersection of the platform barriers when folded away.

3.3.2.2.1 Butterfly

When the platforms are in the raised in a folding motion, position the equipment mounted on the platform also changes in orientation. This may adversely affect the operation of the majority of the rotating equipment, such as the milklines and airlines, the receiver can, and the ACR system and more. Additionally, the placement of the animal orientation railings on the platforms is problematic when the platforms are in their raised position. Interference of the railings in the raised position is a problem that would be difficult to design out. Furthermore, the weight of the folded platform would require an additional system to safely lift and lower the platforms safely as it would be unable safely completed by the operator.

3.3.2.2.2 Taco

The taco design is similar to the butterfly design. However, it allows the central area of the rotating platform to remain level. There is also sufficient area for the platform support rails to avoid interference in the raised position. However, due to the additional width that the platform takes up with the platforms are folded up for transportation, the rotating plant requires a location and locking mechanism to ensure that the platform is within the maximum allowable footprint. Furthermore, although the weight of the platform is less than the butterfly design, the weight of the folded platform would require an additional system to safely lift and lower the platforms providing mechanical assistance to the operator.

3.3.2.3 Ferris wheel

The Ferris wheel design is inherently complicated due to the reorientation of the rotation. This would lead to the utilisation of both a standard platform and rotary system within the area of a trailer. The trailer height and width restrictions constrain the diameter, and width of the Ferris wheel. Due to the small size and complex nature of the plant, there are safety concerns with a significant amount of rotating equipment. This direction of motion of the rotating platforms introduces a risk of entrapment or crushing during operation to the operator of the sheep.

3.3.3 Concept development/design iterations

The rotary concepts butterfly and taco were developed further. The TRIZ inventive principal of segmentation was applied to the individual milking stalls rather than the rotating platform, allowing the rotary to be stored with the maximum width of a trailer during transit and decreasing the applied force required to fold the platforms away. The generation of two developed concepts were considered, the foldaway and flower. The foldaway system had individual platforms that folded vertically when not in use, and that rotated on the rail individually allowing all of the folded platforms to be stored at the front and rear of the platform. The flower concept has platforms that are hinged near the rail allowing the platforms to fold up and over each other during transit. Figure 14 illustrates both iterations of the developed design with the foldaway on the left and flower on the right.

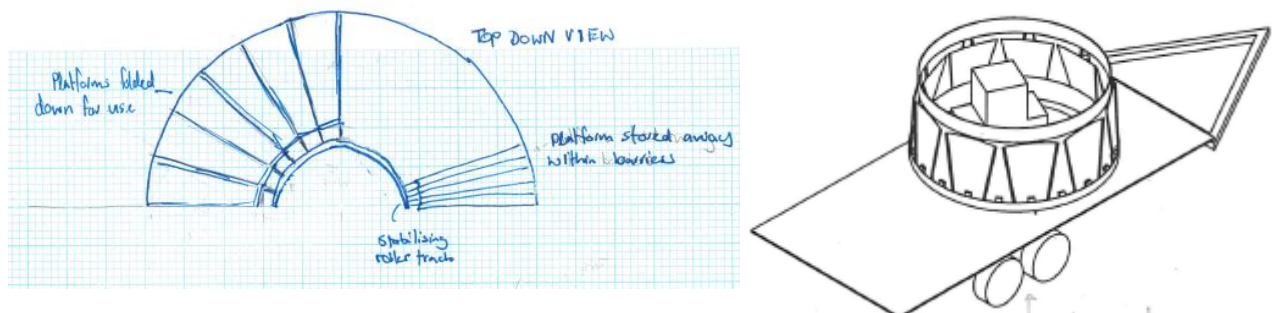

Figure 14 - Foldaway and flower sketches

The foldaway system required a complex attachment system to the rail and the milking system. In particular, connections between the cluster and the receiver can were required to be attached to the platform during transit and operation of the plant. This would require long lengths of flexible tubing adding to the complexity of the system.

The other expanded concept was named the flower system was named as the individual sheep platforms fold up like a flowers petals and night. This used the TRIZ inventive principal nested doll allowing the platforms to fold over each other in the raised position. Its connections to the railing only required a hinge connection and as the platform remained in the same position of the rail respectfully flexible tubing near the hinge point additional to the standard lengths of tubing is only required. The flower was considered the best concept and the design were developed further.

3.4 Embodied design

3.4.1 Milking system

The components for the upgraded design were selected after the NZCP1 modification document was produced. As a result, the selection of the components used in the portable rotary plant is compliant with the modified NZCP1 document that was endorsed by the Ministry of Primary industries. This allows the application process for the portable rotary plant to use the accepted, modified NZCP1 document for the risk management programme rather than adding other modifications that require the reassessment.

Relevant standards for dairy design include the NZCP1 code of practice document, as well as the New Zealand Milking & Pumping Trade (MPTA) Standards. Compliance with the risk management

procedures was additionally used. Discussions with the technicians at Read Industrial Ltd about dairy design and meetings with the industry mentor Ian MacDonald provided supplementary insight for dairy design.

3.4.1.1 General systems layout

The milking systems in a rotary system are split into three main areas the rotating platform, the stationary trailer platform, and the supplementary platform on the towing vehicle.

Milk is transferred out of the rotating plant electricity is transferred into the system a centre gland that is at the centre of rotation. The other remaining systems such as the milk pump, filter and cooler are mounted to the front of the trailer. Mounting at the front of the trailer reduces the connection distance to the bulk milk tank, hot water system and generator mounted on the towing vehicle. The process diagram of the portable rotary milking plant is shown in Figure 15.

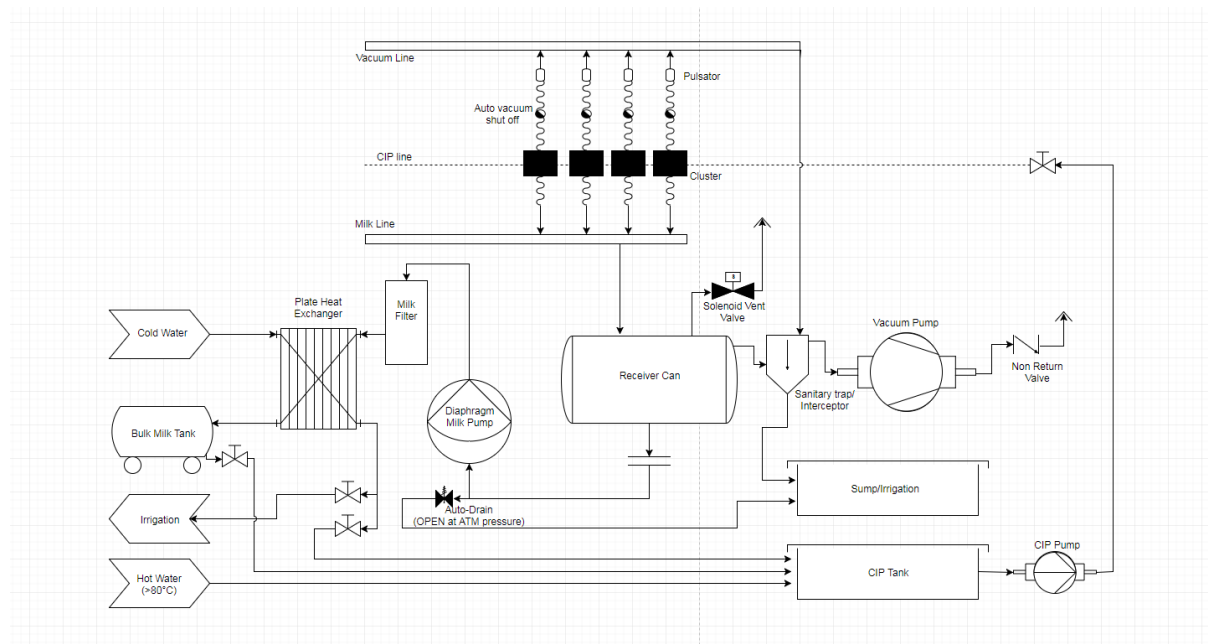

Figure 15 - Process diagram for the portable rotary milking plant

3.4.1.2 Rotating platform

The rotating platform is mounted onto rails and rollers that are aligned with support wheels to allow the plant to rotate on the trailer. The rotating platform including some of the components is shown in Figures 16 and 17. The rotary drive system which is able to control the rotation speed and stop the rotation of the platform when required. The rotating platform has twenty folding platforms that fold down for standard operation and fold upwards for transportation as shown in Figures 18 and 19. The associated systems that are on the milking plant were examined and replaced with a more appropriate system if required.

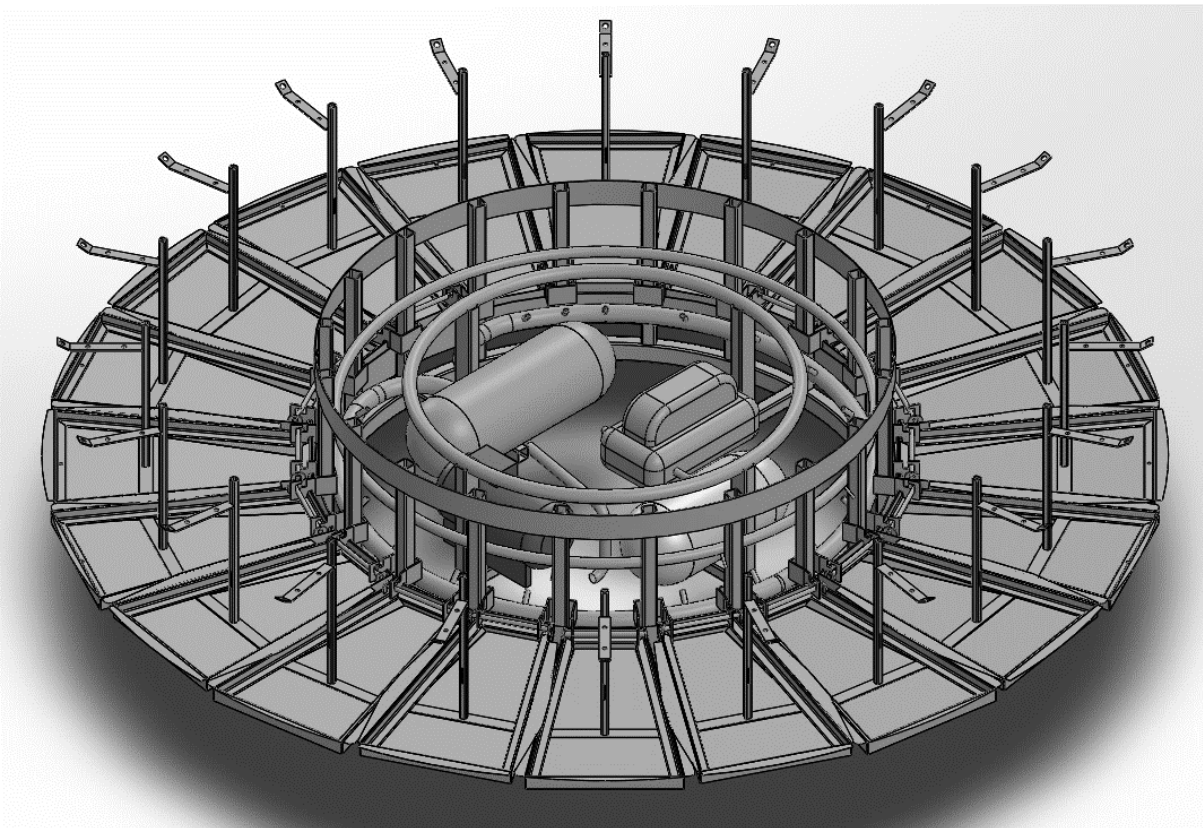

Figure 16 - Rotating system without ACR rams to show component placement

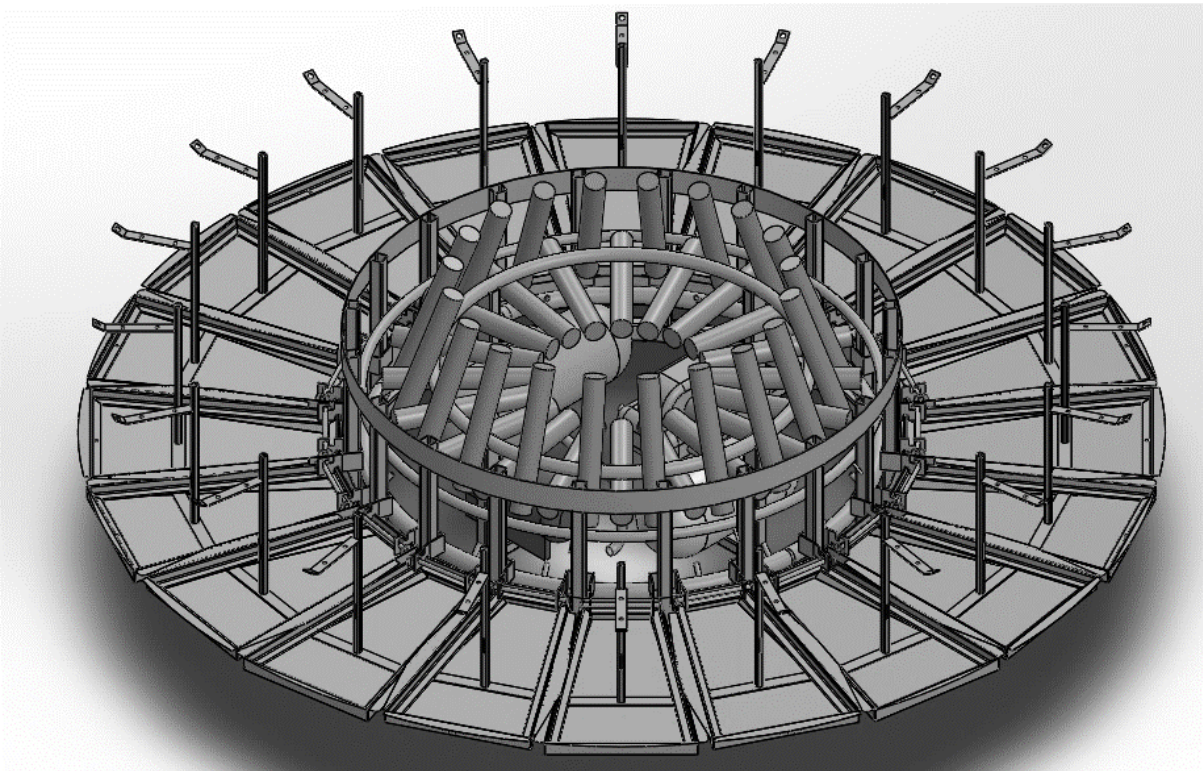

Figure 17 - Rotating platform

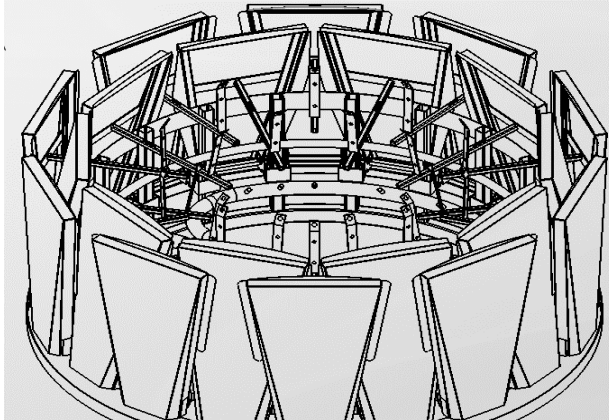

Figure 19 - Rotating platform (platforms folded away)

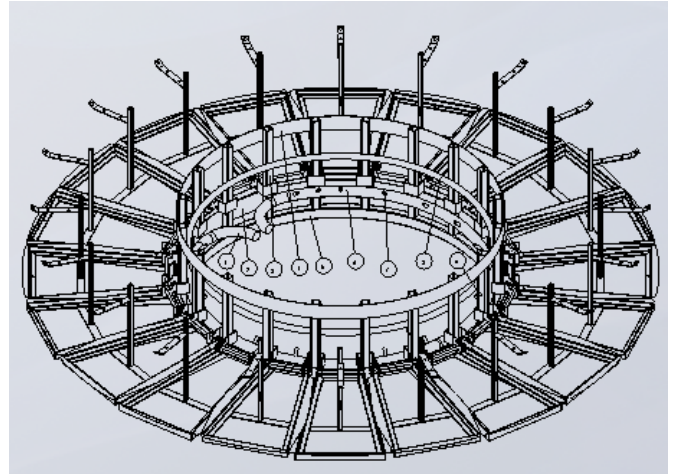

Figure 18 - Rotating platform (platforms down)

3.4.1.2.1 Milcline

The sizing and mounting angles for the milcline sizing are declared in the MPTA standards ((MPTA)). However, the milcline sizing does not go into further detailing how to calculate the appropriate sizing for the number of animals milked, expected milk flow rate and slope of the milcline. The appropriate sizing of the milcline is required to ensure that the two-phase flow of milk within the milcline is stratified allowing the uninterrupted flow of air over the milk. Slug flow occurs within the milcline when there is an insufficient cross-sectional area for the air to flow over the milk, producing slugs of milk within the flow disrupting the vacuum pressure at the teats and effecting the milking of the sheep. Steady airflow enters the milcline from air admission holes in the cluster and leaks at the fittings. Sudden air admissions that enter the milcline via the removal of the cups are a major cause of slug flow within the milcline. Equation 2 was used to calculate the maximum flow rate of milk for the stratified flow was sourced from a journal article by Douglas and Graeme (Douglas J. Reinemann).

$$Q_m^2 = C_3 S^{16/3} F^{8/3} + C_4 \times \left(\frac{Q_a F^{4/3}}{(1-F)^2} \right) \quad (2)$$

Table 8 - Variable values used and description

Variable	Value	Description
Q_m	- l/min	Volumetric flowrate of milk in the milcline
S	- %	Slope of the milcline
D	- m	Diameter of pipe (inner)
F	50%	Fractional cross-sectional area of milk in the milcline
Q_a	181.25 l/min	Volumetric steady flowrate of air in the milcline
C_3	2.4×10^{-6}	Coefficient from journal article
C_4	1.4×10^{-2}	Coefficient from journal article

The coefficients C_3 and C_4 of the equation were determined in the journal article using experimental data from the study of milcline flow with various typical diameter pipes, slopes, and fills. An outline of variables and basic description used for the calculations are in Table 8. The fractional cross-sectional area (F) was determined as milk flow as the transitional period between stratified and slug flows is within a fractional cross-sectional area of 30% to 70%. The steady volumetric flowrate of air was determined from the volumetric flowrate of air of the clusters disclosed in the machine test report of the current milking plant. The maximum volumetric milk flow rate of an individual stall of the milking plant of the twenty stalls connected to the milcline using various slopes and diameters of milcline

were calculated and are disclosed in Table 9. The inner diameter of 60mm or 2.5" milklime was selected as it allows the flowrate of 1.8 to 2.5 l/min over slopes of 1% to 2%. A 2.5" milklime at a slope exceeding 1.5% will allow to flow of milk within the milklime to be stratified and not slug flow for the expected maximum milk flow rate of 2l/min produced from the sheep.

Table 9 - Maximum volume of milk produced from 1/20 stalls using various diameters of milklime and slope

	Slope [%]		
	2	1.5	1
Inner diameter of pipe			
48.5	1.57	1.41	1.24
60	2.52	2.22	1.87
73	4.12	3.59	2.97

The milklime has 20 radial ports evenly distributed around the circumference apart from near the receiver can due to bends. The ports near the bends are typical with standard milklime design and only requires longer milk tubes of the ports. The ports are also mounted at a 45° incline angle on the internal of the milking platform to prevent backflow and prevent excessive bending of the milk tubes. The milklime is mounted to the internal of the vertical supports and is slightly lower than the platform that the sheep stands indicating that the system is lowline.

3.4.1.2.2 Airline

The airline diameter is determined by the pressure losses within the airline. Effective lengths are given to bends and potential obstructions. The vacuum drop per meter (kPa/m) at various flow rates and pipe sizes for stainless steel pipe are used to ensure that the vacuum drop does not exceed 5kPa. The MPTA standards give expected head losses for typical 50mm and 63mm (2" and 2.5") airlines. However, due to the smaller size sheep milking plant and system, a smaller airline would be better suited. This requires the calculation of the head losses in 38.1mm (1.5") airline. The vacuum drop was calculated for the designed airline using the Darcy-Weisbach Equation (Equation 3). This equation confirmed that the vacuum drop of the system would not exceed 5kPa/m.

$$\Delta P = \frac{\lambda v^2 \rho}{2d} \quad (3)$$

According to the MPTA standards, the effective length of the airline of the proposed rotary plant is expected to be 4.8m based on the effective length guide in the MPTA standards ((MPTA)). The air flow rate of the vacuum pump is 2,000 l/min producing a bulk air flow speed of 29.23m/s in a 38.1mm airline. The Reynolds Number of the flow is 67,000 indicating that the flow is turbulent. The absolute roughness of the stainless steel airline is expected to be 0.0015mm (*Major loss in ducts, tubes and pipes*). The friction coefficient (λ) was determined using a Moody diagram as 0.067. The overall pressure drop of the system was calculated to be 4.327 kPa using the 38.1mm airline.

The airline is mounted above the milklime and has only ten radial ports. At each of the ports is a nupulse electronic 2x2 pulsator. The 2x2 pulsators can supply the pulsated air to two clusters and are connected to the clusters via the dropper tube. The electronic pulsators are used as they are more capable of producing high pulsation rate of approximately 180 pulses per minute that is required to milk sheep efficiently.

3.4.1.2.1 Clusters and dropper tube

The Interpuls 207 cluster has been successfully used on the previous portable sheep plants. The Interpuls 207 cluster are specifically designed for sheep and have an automatic shutoff valve that shuts

off the cluster vacuum when not in use (attached to anything that seals the cluster). As the cluster automatically shuts off, the amount of air that is admitted into the milkline is reduced. Therefore, reducing instances of slug flow within the milkline, foreign matter entering the cluster, and cluster drop-off at nearby stalls due to loss of vacuum. Hence, Interpuls 207 are used in the current iteration of the plant.

Dropper tubes transfer the milk and vacuum pulsation from the flexible rubber tubing connected to the cluster, and to the milkline or pulsator, respectfully. The dropper tubes are solid stainless tubes mounted horizontally on the platform, and are used to reduce the length of rubber tubing used on the milking plant. A flexible rubber tube connection between the dropper to the pulsator or milkline allows the platforms to be folded away. Two sizes of tubing are used, including is 3/4" for the milktube and 3/8" for the pulsators tube. Flexible rubber tubing connects from the cluster to the dropper tube and from the dropper tube to the milkline. A flexible linkage is required for the connection to the milkline to allow the platform to be folded away. Figure 22 shows a mock-up of the platform with the connections from the clusters to the dropper tube. If the ACR system is used a milk flow meter is to be mounted on the milkline ports at a 45° angle allowing the milk to not collect in the flowmeter and drain into the milkline.

3.4.1.2.1 Receiver can and sanitary trap

The receiver can, and sanitary trap are constructed of stainless steel with plastic domes that clip onto the outer edges of the can. The receiver can is mounted to the lowered platform in the centre of the rotating platform. The inlet ports are halfway up the centre of the receiver can allowing sufficient surplus volume allowing the separation of the milk and air. The sanitary trap is mounted opposing the receiver can and separates the vacuum, and any contaminants that enter the sanitary trap before it enters the vacuum pump. Any liquids that are collected are emptied through a drain port at the bottom of the tank. The volume of the receiver can, and the sanitary trap is 56 litres and 42 litres respectfully.

3.4.1.2.2 Vacuum pump

The vacuum pump is mounted on a lowered platform in the centre of the rotating platform. The vacuum pump selected is an M4 Skullerup pump capable of producing the required vacuum according to the MPTA standards. The pump is driven by pulleys and Vee belt by a 5.5kW electronic motor mounted on the other side. The power requirements of the electronic motor match that of the previous plant as the generator used to power the plant is fully capable of supplying the required power to start and operate the motor.

The vacuum system is placed on the rotating platform as this means that the centre gland is not required to transfer air between the stationary and rotating platform. Commonly in rotary designs, the vacuum pump is placed in a separate room due to the noise that is produced. The noise produced by the small oil vane vacuum pump that is used on the current plant is not as loud as vacuum pumps used on larger milking systems. The current 16 single aside plant vacuum pump is mounted onto the trailer frame and is not fully enclosed (except for a perforated mesh as a protective guard) and does not irritate or stress the sheep during operation.

3.4.1.2.3 Vacuum ventilation

Venting of the vacuum system is required to reduce the pressure difference between the vacuum system and the atmosphere produced by the powered vacuum pump and provide an alternate source of air admission. When the vacuum pump is turned off, and the vacuum system is not vented, the air enters the vacuum system via the vacuum pump, causing the pump rotor to counter rotate can cause damage to the vanes and cause premature failure of the vacuum pump. The common system venting practice is to remove a rubber bung from the receiver can. This ventilates the vacuum system before the vacuum pump is turned off preventing the pressure difference and associated damage via counter rotation. However, as the receiver can is placed in the centre of the platform, it is not able to be easily

accessed. There are two potential methods to solve this issue: adding a backflow inhibitor, or solenoid valve. A back-flow inhibitor mounted to the exhaust of the vacuum pump inhibits the rapid air intake to the vacuum pump and the vacuum system. The slower rate of ventilation of the venting reduces the speed of the counter rotation and associated damage to the vacuum pump. Alternatively, a 2" solenoid could be used to ventilate the system. The solenoid can be electronically opened with a switch, venting the system, in a similar manner to common practice, before the vacuum pump is turned off. The back-flow preventer was selected for the design as it was cost effective and reduces the complexity of the vacuum system design.

3.4.1.2.4 ACR and bail rams

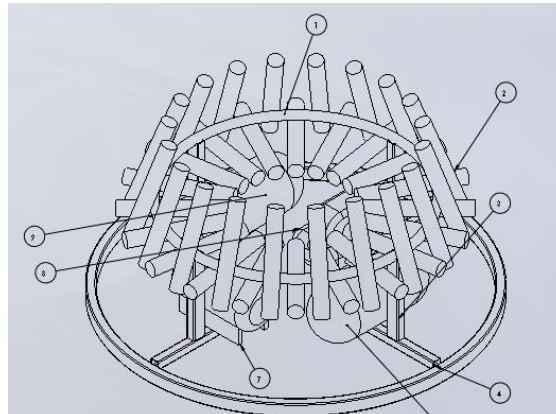

Figure 20 - ACR and bail ram mounting configuration

The system will use the automatic cluster removal systems available at Read Industrial Ltd. These systems in combination with a bail strap system are typical for external rotary systems as described in section 1.3.2.1. Due to the size constraints of the plant, all the rams that are used are the shorter bail strap rams that are 200mm shorter, so they do not intersect at the centre of the platform. Additionally, the bail strap ram is mounted at an angle to allow the platforms to be folded up and not to intersect with the ACR rams. The rams are mounted with pipe mounts to the CIP line horizontally and at an angle of 20° from vertical as shown in Figure 20.

The rams have an internal piston that is connected to the cluster via a rope. The vacuum system is utilised by evacuating the air from above the piston in the ram raising the ram, extracting the rope and removing the cluster from the animal. The horizontal rams are the ACR rams control the removal of the clusters via a rope guide on the platform. The angled rams control the raising of the bail strap via additional rope rerouting the rope to an elevated position at the top of the ram to raise the bail strap.

Typically, the cluster is protected with a teardrop barrier to avoid accidentally dislodging the cluster and triggering the quick release mechanism as shown in Figure 21. However, due to space constraints, there is negligible protection for the cluster against being kicked or dislodged by the sheep illustrated in the mock-up of the platform shown in Figure 22. As a result, the ACR may prematurely disengage and may potentially cause damage to the clusters on the platform. A switch may be used to disengage the ram. However, adding the switch will require an additional manual task when placing the cluster on the sheep rather than the mechanically assisted task of engaging the quick release. As the quick release mechanism is inherent in the design of the ACR ram, the quick release mechanism can be trialled to monitor the occurrence of the unwanted accidental quick release.

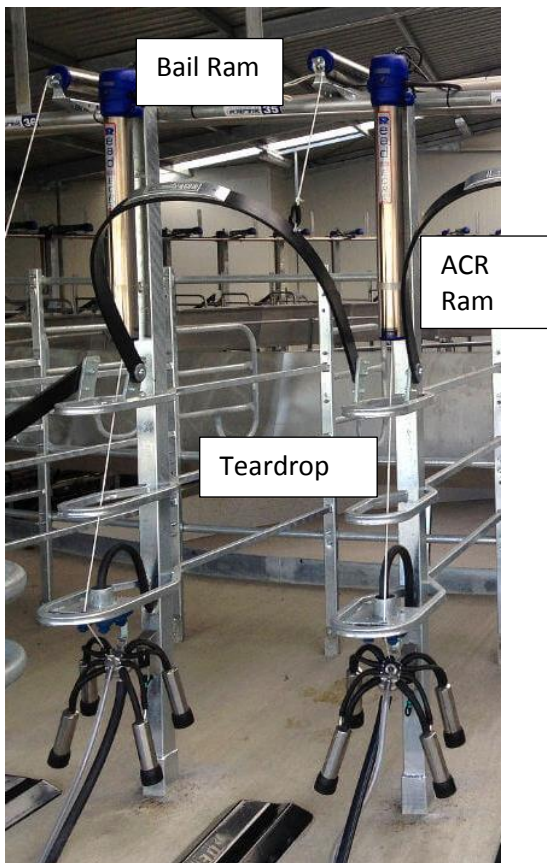

Figure 21 - Typical rotary ACR system

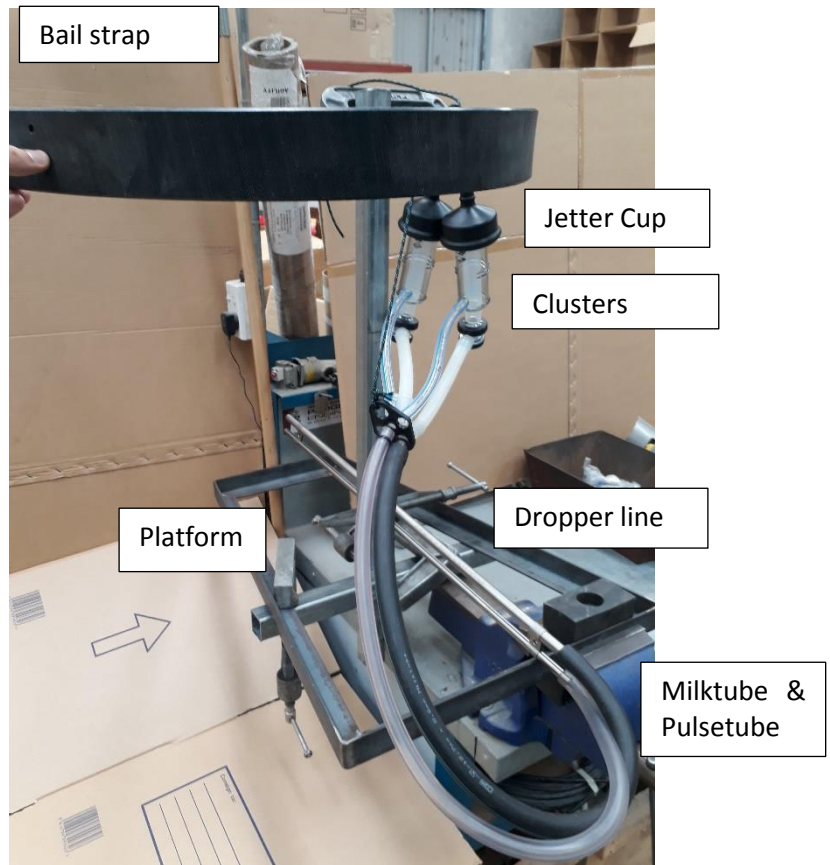

Figure 22 - Mock-up of platform and cluster positioning

The rotary milking system can upscale to the milking throughput required. Additions to the milking system that would be required for a single operator to operate the plant is the ACR system. This system requires the addition of an electronic milk meter at each milking line, a cluster removal system, and possibly a bail strap remover system and a controller to control the automatic operation of the system.

3.4.1.2.5 CIP wash system

The CIP wash system consists of the CIP line which is also the ACR ram mount. The CIP line is 2" stainless steel with 20 downward facing radial ports for a ¾" rubber hose to be connected to the jetter cups. The jetter cups secure and transfer the CIP wash to the clusters for cleaning via a recirculating system. A flexible linkage is required to ensure that it does not inhibit the platforms folding up or down. The CIP wash occurs while the platform is stationary. To clean the system after milking has been completed, a hose between the CIP tank and the CIP line must be attached completing the recirculation loop of the CIP.

3.4.1.2.6 Jettors

The existing plant used jettor cups that are no longer available. As a result, another jettor cup product was required. The mounting point on the platform on the vertical bail raiser the width of the jettor cannot exceed 80mm to allow the platforms to fold away. Standard jettor designs are typical for use with cow dairies have four jettor cups per jettor, which cannot be easily modified for the two cups on a sheep cluster and within the maximum allowable width to allow the platforms to fold away. The Hyjet jettors from Skullerup were best suited as they were individual cups and could be easily mounted along with ACR rope guide and are within the maximum allowable width.

3.4.1.2.7 Effluent tray

The effluent of the system is managed in a similar manner to that of the current plant. The effluent is collected under the perforated floor of the platforms, which empty into an inclined circular collection tray. The collection tray is sloped to a recessed collection point with a drain port that empties into the effluent tank for disposal. However, as the collection tray is rotating with the platforms, the emptying of the collection tray into the effluent tank can only be completed when the platform is stationary. The low volume of effluent produced by the sheep while on the platform ensures that the system will not overflow during operation.

3.4.1.2.8 Platforms

The platform that the sheep stands on during milking is a perforated sheet mounted over a collection tray. The folding platforms on the rotary system each have individual perforated plates and collection trays. The sheep straddles between two platforms with overlapping tabs directing the effluent into the collection tray of either platform. Every second platform has a hinge point closer to the centre of rotation and thus overlaps the platforms, which hinge further from the centre of rotation. Figures 18 and 19 show the platforms in their lowered and raised state.

The bail straps retain the sheep within the stall. The platform, bail strap, and platform separator are used to align the sheep. The length of the platform is 900mm, which is sufficient for a sheep with its head over the interior railing and secure the sheep throughout milking with the bail strap. The estimated height of the platform above the ground when the system is used on a level surface is 900mm, this positions the udder at the height of 1m, similar to what is used on the current plant.

The platform will use a wire rope mounted between the upper ring, through a slot platform divider and is attached to at a mounting hole at the centre rear of the platform. This provides the support force for the platform when the platform is in use and does not impede the folding of the platform.

3.4.1.2.1 Hinges

The platforms are mounted on a hinge that allows the platform to be folded away. The hinges for the lower platforms are located further from the centre of rotation than the hinges for the upper platform. This geometry allows the lower platforms fold up to a vertical position outside the upper platforms. A slot pattern is used to allow the platforms to detach from the rotating platform without disassembly. The hinges also have a cavity that the front of the platform folds away into and can support the structure in the case of a failure of the supporting wire rope.

3.4.1.2.2 Railings

Railings are required to orientate and secure the sheep on the platform while milking. The sheep are secured during milking to prevent excessive movement which disrupts the milking of the neighbouring sheep and increases the occurrence of cluster kick off. Securing the sheep can be completed using two strategies, head hold or bail strap (rear railing).

The head hold system requires the sheep to place their head into a mechanism that secures their head when required during the milking of the sheep. Supplementary feed is used as an incentive for the sheep to place their head into the head locking mechanism, and tripping a mechanism that opens the

sequential neighbouring headlock mechanism for the following sheep to use. The head holding systems are used internationally. However, they are not prevalent in New Zealand.

A bail strap or rear railing can be used to secure the sheep onto the platform. The bail strap is a flexible plastic strap mounted to either side of the sheep and folded down and around the sheep during milking preventing the sheep from backing out. Additional weight can be placed on the bail strap allowing it to lower around the sheep with its self-weight as the sheep walks on to the rotating platform and then checked by the operator as they place the cups on the sheep. The bail strap as detailed in the ACR and bail rams section (section 3.4.1.2.4) can be used in combination with an ACR system. The ACR system raises the bail strap after milking is completed and the sheep are able to walk off safely onto the offramp platform. Bail straps are common to rotary systems in New Zealand with ACR and are more easily acquired and implemented than the head hold system. As a result, bail straps are used to secure the sheep on the platform on the portable milking system.

3.4.1.3 *Stationary trailer platform*

Components are mounted to the stationary trailer platform and do not rotate with the rotating platform. The following systems transfer and complete pre-processing of the milk before it is transferred to the bulk milk tank, as well as drive the rotating platform, manage the sheep walking onto the rotating platform and the store of the CIP and effluent wastewater.

3.4.1.3.1 *Milk pump*

A two head Flynn diaphragm milking pump is to be used to pump the milk collected in the receiver can and into the milk tank. The diaphragm milk pump is able to produce suction pressure and is able to self-prime. As the piping raises from the centre gland to the milk pump, a self-priming pump is essential. Additionally, diaphragm pumps have a lower impact on the milk quality than centrifugal pumps due to their lower turbulence generation. The pump is to be placed at the front of the trailer to provide access for maintenance and proximity to the filter and cooler. However, it could be placed under the rotating platform if a third tank is not required and is preferential.

3.4.1.3.2 *Filter*

A 2" milk filter is used to filter the milk before entering the cooler and removes contaminants in the milk. The sizing of the milk filter is appropriate for milking approximately 400 sheep at a time. As the plant is capable of milking up to 400 sheep an hour, this may require that the filters are replaced every hour, or a larger 4" milk filter could be used. The filters are easily replaced with a disposable or reusable filter. Disposable filters are used on the current plant as they are more convenient than the reusable filter which requires an additional cleaning process and ongoing record keeping.

3.4.1.3.3 *Cooler*

A plate heat exchanger similar to what is used on the current plant is to be used on the rotary milking plant. The cooling capacity of the current heat exchanger using water supplied by a bore on the farm is capable of cooling the milk to less than 15°C and therefore reducing the cooling load to the refrigerator in the bulk milk tank

3.4.1.3.1 Rotary drive system

The rotary drive system for the small rotary design required much less torque than typical cow rotary milking plants. Typically, the drive system uses two counter driven wheels either side of the rail powered by individual gearmotors and spring loaded to ensure contact between the drive wheel and the rail. The redesigned drive system uses a single drive wheel that mounted on a sliding platform and is spring loaded onto the rail, the configuration of the drive motor is shown in Figure 23. Two undriven wheels mounted to the external of the rail are spring loaded and are used to provide a countering force to the drive system to ensure that the drive wheel is in full contact with the rotating rail.

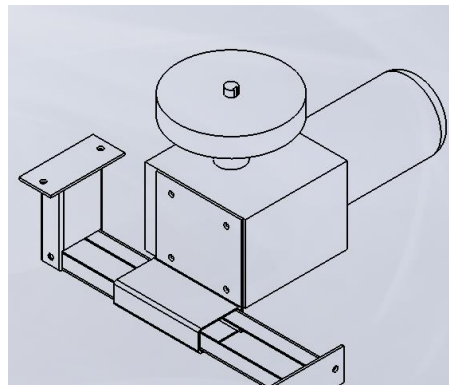

Figure 23 - Rotary drive system

3.4.1.3.2 Effluent tank/ CIP tank

There are two tanks used for the effluent and CIP systems, with additional space for a third if required. The tanks have a capacity of 100 litres potentially allowing the total storage of 300 litres of fluid. A flexible temporary hose connection is required to connect to the rotating platform allowing it to empty into the effluent tanks when the rotating plant is stationary. Additionally, the effluent tanks require an access port to clean the tank and an outlet port that allows the tanks to be emptied fully using the effluent dispersal system.

3.4.1.3.3 Platform

The use of the rotary system will require modifications to the off-ramp and on-ramp design. Design considerations for rotary systems include non-slip footing, minimal platform slop at the rotary entrance, sufficient area for the sheep to turn around, and lighting of the dairy.

The rotating platform has a landing area allowing the sheep to walk onto and off the rotating platform. The two transitions include transitioning from the ground to the landing area, from the landing area onto the rotating platform and rotating platform to the landing area, and landing area to ground. The landing area provides an additional area for the removal of the dirt that is not on the single aside plants.

3.4.1.4 Supplementary platform

The supplementary platform is located on the towing vehicle and is used to place components that are too bulky to be placed on the trailer. The updated rotary system will use the deck on the back of the towing vehicle to mount these components, so they are easily accessible to the milking plant in a similar manner to what the current system uses.

3.4.1.4.1 Hot water

An LPG califont will heat the water for the CIP wash. Currently, the system uses a portable enclosed fireplace with a wetback to heat water to the required 80°C required to sanitise the plant. The LPG califont selected is capable of heating 16 litres per minute and does not require electricity to operate. This system will be mounted to the towing vehicle with a 40kg LPG tank. In contrast to the existing

plant, this allows the entire milking system to be transported as a single truck and trailer system. Additionally, the califont does not require the storage of heated water and can operate on demand.

3.4.1.4.2 Bulk milk tank

A 900-litre refrigerated milk tank will be used to store and cool the milk in accordance with food safety regulations. The refrigeration unit will be mounted to the towing vehicle. The 900-litre tank currently being used is capable of cooling and storing the milk at 3.5°C. At start up, the milk tank is connected to the milking system and is disconnected before cleaning of the milking system or during transportation. The cleaning of the milk tank is completed with the milking system when the bulk milk tank is empty.

3.4.1.4.3 Generator

A 15kW diesel generator is required to power the current system. The typical nominal power requirement for the system is 6kW. The vacuum pump motor requires 5.5kW of power to operate the pump, and 0.5kW for the remainder of the plant including milk pump, ACR systems and rotary drive. The start-up of the plant represents the peak electrical demand of the system. In particular, the 15kW is required for the vacuum pump motor start up, and 1.5kW for starting the remainder of the plant. The generator is capable of providing the start-up power if the system is started sequentially.

3.4.2 Effluent disposal system

As described earlier in section 2.2.2.1 the current effluent disposal system can dispose the effluent, and CIP wastewater within regulations defined in NZCP1 and the regional authority (Environment Canterbury). Due to the modification of the design, increasing throughput and compliance with other regional authority regulations, the additional wastewater practices were developed. Additionally, as detailed in section 3.4.1.3.4, the trailer can support up to three 100 litre tanks. This allows the separation of the CIP and effluent tanks. The separation aids in the disposal of the CIP wash water which can be disposed separately from the effluent. This reduces the total volume of effluent that is disposed of allowing a lower effluent disposal volume for land application or a smaller oxidation pond to treat the effluent.

Overall as the regulations vary for each regional authority in New Zealand and the effluent system should be assessed independently in each region to ensure that the plant meets the regulations set out by the regional authority. Factors that affect the effluent disposal volumes for the assessment into calculating the expected amount of effluent for disposal are located in section 2.2.2.1.1.

3.4.3 Trailer design

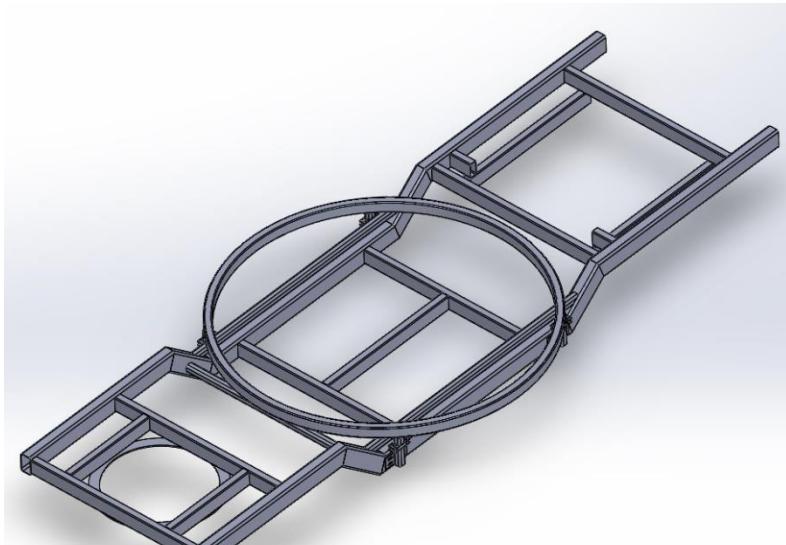

Figure 24 - Trailer chassis

The design of the trailer frame aims to maximise the utility of the portable milking plant for sheep milking by optimising the trailer layout and using the trailer design standards. The agricultural trailer guidelines were used for the design of the previous plant. The intended registration of an agricultural trailer for use on public roads applies additional regulations that restrict the transport distances of the system. However, the agricultural trailer standards provide an adequate travel distance and speeds on the open road that does not affect the functionality of the milking plant. In particular, the current risk management programme restricts the plant to operate at one farm ('Agricultural vehicles guide'). Compliance to the light trailer standard (NZS 5467) would supersede the agricultural trailer guidelines and remove the restrictions, and the portable milking plant would be legally considered as a standard light trailer rather than agricultural trailer.

3.4.3.1 Trailer wheel arrangement

The prototype trailer uses an articulating axle at the front of the trailer and a fixed axle at the rear. This increases the maneuverability and stability compared to single or double fixed axle arrangement and allows the current prototype system to operate without the support of the towing vehicle or outrigger stands. The self-supporting feature of using the articulated axle reduces the trailer hitch load supporting the front weight of the trailer. The drawbar of the articulated trailer is pinned either side of the articulated axle frame the hitch weight of the trailer is estimated to be 40kg which does not exceed the minimum trailer hitch weight outlined in the light trailer standard.

The hitch weight of the trailer is an important part of the yaw stability of the design during transport. Negative hitch weight is undesirable as it may lead to the potential unhitching of the trailer or snaking. As a result, there are recommended hitch weights in the light trailer standard for common single or tandem axle trailers. As the single and tandem axle trailers pivot on the axles, some of the weight of the trailer is distributed to the trailer hitch. The minimum trailer hitch weight for a 2000kg trailer is at least 200kg (10% of the trailer mass). Additional hitch weight could be applied to the drawbar so that the trailer is compliant with the light trailer standard adding to the total weight of the trailer. Alternatively, there are stability tests that can be used to prove the stability of the trailer for compliance with the light trailer standards. The stability cannot be determined during the design phase and requires the construction and physical testing of the trailer. As a result, the trailer will have to be registered as an agricultural implement. Since the trailer must be compliant with the light trailer standard, the trailer will must either complete the stability test or add the required weight to the drawbar.

3.4.3.2 *Trailer frame*

The trailer chassis has a lowered area around the rotating platform to ensure that the platform is at an ergonomically appropriate height for the operator. This also lowered the centre of mass of the rotating platform and the trailer.

The trailer structure must consider the changing weight distribution of the sheep on the on-ramp and off-ramp as well as fully loaded and eccentrically loaded operation. The placement and mounting of these systems on the trailer and the associated loading of the animals must also be considered. To distribute the static and dynamic loads of the plant, sheep and milk, wheel placement must be optimised to prevent the trailer becoming unstable during loading.

Additional outrigger stabilising devices will be installed on the trailer to stabilise and distribute the weight to the ground in all loading conditions. The design of the system may use hydraulic or screw jacks with stabilising base to elevate the platform at the four corners, so the system is level during operation on the uneven ground and to reduce the deflection of suspension during dynamic loads.

3.4.3.3 *Trailer loading*

During the analysis of the trailer, a series of loading conditions were tested on the drawbar and the frame to ensure compliance with the light trailer standards and to assure that the deflection does not exceed allowable limits for the standard loading conditions.

"Drawbars, their attachment devices and the structure of the trailer shall withstand the loads shown below without incurring loss of attachment or distortion or failure which would affect the safe towing of the trailer:

- | | |
|---|--|
| a) Longitudinal tension and compression | 1.5 times the specified towing capacity |
| b) Transverse loading | 0.5 times the specified towing capacity |
| c) Vertical loading | 0.5 times the specified towing capacity" |
- (Zealand)

3.4.4 *Operational procedures*

The operation of the plant is similar to other rotary systems. The sheep walk up onto the onramp platform and then onto the platforms. A bail strap is lowered around the sheep manually to prevent them from backing off the platform. The cluster is manually placed on the sheep that is milked out as the platform is rotated. At 300 degrees of rotation, the cluster is removed by an ACR system, and the bail strap is lifted allowing the sheep to walk off the platform via the off-ramp platform and toward pastures.

The selection of sheep for remilking and retention on the rotating platform could be completed either with the use of an Automatic Cup Removal (ACR) system commonly used with rotary design or another operator near the exit of the platform.

3.5 *Evaluation*

The application of the TRIZ identified solutions requires a reevaluation of the suitability of the components used on the plant. Components that were deemed possibly unsuitable for the TRIZ optimised plant were reassessed. Additionally, evaluation of the expected increased production capabilities of the optimised design produced from the TRIZ methodology was also assessed

3.5.1 *Component evaluation*

The impact of applying the TRIZ identified solutions may disturb other linked design components in the design, requiring re-evaluation of contradictions to iterate towards an optimal design. An analysis of the potential impact of the proposed solutions and introduction and removal of components was undertaken to ensure that each element of the function map remained operational. The following sections determine how the new proposed functions and systems affect the original systems.

3.5.2 Production and component layout analysis

3.5.2.1 *Production*

The improved plant is estimated to milk 400 sheep per hour. This is possible with a rotational speed of a third of a revolution per minute with the sheep. This includes dispensation for slow milking sheep to complete another rotation. After production, the rotational speed may be modulated to suit particular flocks and achieve optimal efficiency.

3.5.2.2 *Retaining within the trailer area*

The folding of the platforms allows the plant to remain within the maximum trailer width for transport on New Zealand public roads. Only the platforms that extend past the maximum width need to be folded away for transport. However, as the platform folds over each other folding all of the platforms is recommended as it provides additional support for securing the platforms during transport.

3.5.2.3 *Convenience of use*

The proposed layout is more convenient to use than the previous single side plant. A single operator with the ACR system can operate the plant on their own. Alternatively, if ACR is not installed, two operators are required. Adjustable platform height with the screw jacks accommodates variable operator heights. However, a potential inconvenience of the external rotary system is that a single operator cannot assess the milking of the sheep throughout the complete rotation of the platform. This would be possible with two rejected concepts: the single side and internal rotary systems. While observing sheep through milking has some mild benefits, it is not often beneficial and is not a requirement for safe or efficient sheep milking.

3.5.3 TRIZ reflection

The TRIZ methodology aided the design of a more efficient and fit for purpose plant that is expected to milk twice as many sheep as the previous iteration while remaining within a similar footprint and weight of the previous plant. The systematic approach to the design and use of the inventive principals aided in the production of ideas to solve the contradictions identified logically with the use of the function map and trimming process. As the project was undertaken, the inventive principals introduced ideas that resolved the contradictions quickly. The TRIZ methodology provides an individual designer with rapid idea generation tools. The methodology can be applied to collaborative design. However, the approach may not be as efficient in larger groups as idea generation in a group is typically fast. The application of the inventive principals provides a range of inventive principals at the start of the idea generation process that is suited to resolve or remove the contradiction and resolve the particular problem. The process additionally provides a foundation to research mechanics and principals relevant to the particular problem, aiding the ability to produce a design that removes the contradiction. For this reason, TRIZ appears to provide a more efficient methodology for design idea generation and contradiction resolution than relying on the intuition of the engineer.

4 Modelling

The modelling of the platform used computer aided design software and finite element analysis to determine the structural layout of the trailer frame and to determine the stresses within the structure during different loading cases.

4.1 Computer aided design (CAD)

The computer aided design (CAD) model was produced using Solidworks 2014 software. Structural members were designed to standard sections defined in the Steel and Tube catalogue.

The CAD model was used to determine the placement of the required systems. Additionally, the physical model was used in the FEA analysis of the system to ensure that the plant chassis was capable of the self-weight and operational load during milking and transit.

The overall weight of the plant is estimated to be 1740kg. However, the final build version of the trailer is likely to deviate from this weight. The estimated weight of the rotating platform is 700kg comprising of 580kg of framework and the remainder made up of components on the rotating platform. The framework of the trailer is 240kg, and the remaining components are 800kg not including the wet weight of the system. The weight of the framework is calculated using the unit weight per meter supplied by steel and tube in the catalogue and the lengths of the members that are used ('Product Catalogue Steel'). The maximum wastewater weight of the three tanks filled adds an additional 300kg to the system. Water is not stored on the plant and is emptied immediately after milking.

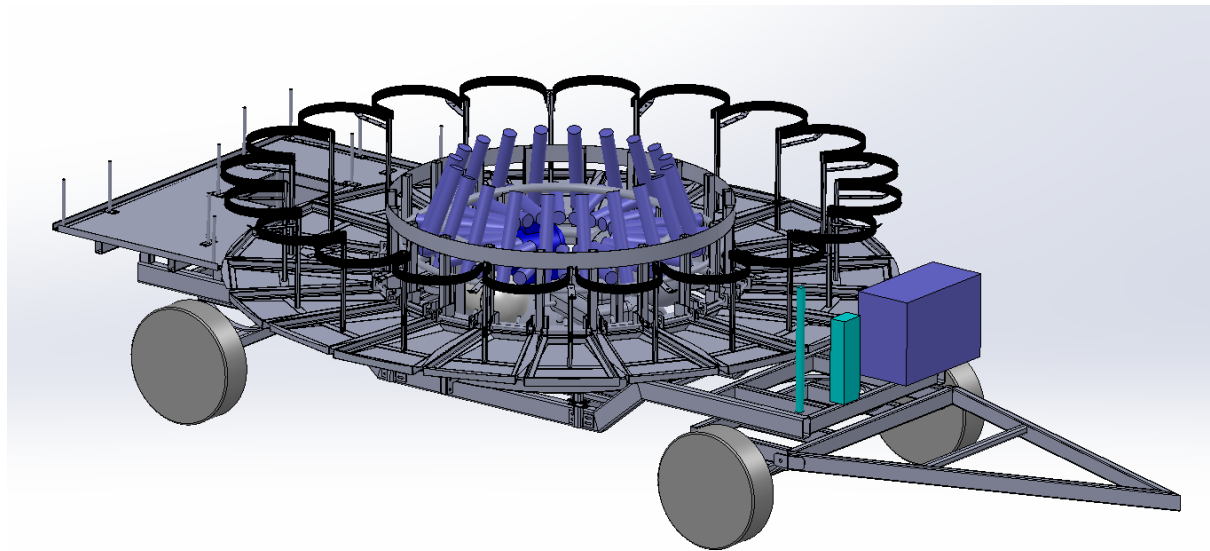

Figure 25 - Plant layout

The layout of the underlying milk systems is shown in Figure 25. The vacuum pump and the electric motor, as well as the sanitary trap and receiver can, are placed within the centre of the rotating platform. The milk pump, filter and cooler are mounted at the front of the platform to allow easy operator access and connections to other milking systems on the towing vehicle. These systems include the hot water califont, generator and milk tank.

The folding mechanism design was completed with the assistance of the CAD software allowing the visualisation of the folding procedure and to ensure that there is no interference between the platforms. The raised platform divider was placed in the centre of the platform to allow it to fit within the platforms either side when folded away. The mounting angles of the ACR rams were determined so that they do not intersect with the platforms in the folded state as shown in Figure 20.

4.2 Finite element analysis (FEA)

A static structural analysis was completed on the trailer frame, drawbar and platforms to ensure that the design is able to withstand the applied loading without excessive deformation or stress. Due to the complexity of the structure, the analysis warranted the use of FEA software to determine the expected deformations or stresses. Analyses of the structural components of the trailer were undertaken using an ANSYS finite element analysis.

4.2.1 Geometry

The software used to generate the CAD model (Solidworks 2014 Professional Version) has a weldment feature that applies a welded connection between connected members. The weld bead function can be used to represent the welds at these connections. The weld beads that are produced using this function do not create a model part in the assembly. As they do not create a part, the weld in the CAD model is thus not transferred to the FEA software for analysis. As a result, the additional welded bead on the system are not represented in this analysis.

4.2.2 Material properties

The model used the standard material properties of structural steel to be used to define the stiffness of the model. Additionally, the yield and tensile strength from the Steel and Tube Duragalv material was used to determine possible failure of the structures ('Product Catalogue Steel'). Table 10 lists the material properties used in the FEA modelling of the structures.

Table 10 - Material properties of the structural steel members

Property	Value
Young's modulus	2×10^{11} Pa
Poisson's Ratio	0.3
Shear modulus	7.69×10^{10} Pa
Design yield stress	450MPa
Ultimate tensile strength	500MPa

4.2.3 Connections

The contact type that was used for all the contacts between the members was a bonded contact, with no movement normal to the contact surface (separation) and no movement tangential to the contact surface (sliding). The final build of the platform will include a weld bead on the circumference of intersections mated surfaces. Hence the bonded contact assumption is false. Furthermore, at sharp transitions between the mated surfaces, stress singularities can occur at intersections of connected members (Acin)

4.2.4 Meshing

Meshing was completed using proximity and curvature setting in ANSYS. Curvature examines the curvature on the edges and faces and sets the size of the elements to not violate the maximum size or curvature angle. Proximity specifies that a minimum of three cell layers are created in regions labelled as gaps between connection surfaces. (*Meshing in Mechanical*)

The 'relevance centre' setting was reduced to fine, which increased the resolution and accuracy of the mesh. Additionally, the proximity minimum size was increased, increasing the mesh size especially near the edges and surfaces of members. This increased the size of the mesh at the edges and faces as well as the remainder of the model reduced the severity of the stress singularities in the model as well as to reduce the computational power required to for the FEA analysis.

4.2.5 Loading

Structural loading of the structure was completed using the application of force and moment loads to the trailer that represents the typical loading and extreme loading of the drawbar. Additionally, the trailer chassis and platform were tested under typical loading conditions. Various loading and support

conditions were used to represent loading in typical conditions. Additionally, inertial loading of all the structure was used to simulate the gravitational loading of the trailer frame under its self-weight.

As the system uses an articulated axle, the stresses that were tested the maximum expected loadings included the drawbar loaded with a transverse side load, tension and compression. Additionally, the frame was tested with vertical loading with the expected loads of the trailer including the weight of the rotating platform when loaded evenly and the weight of filled water tanks. Lastly, the rotating platform was tested using expected loading of 80kg sheep evenly distributed on the platform.

4.2.6 Solver

The analyses were undertaken in ANSYS. The analyses used static assumptions to calculate the deformation and stress. The model renders of Figures 26-31 are rendered with a highly exaggerated deformation to enable better model interpretation.

4.2.7 Structural loading

The safety factor required for the designs was determined to be 2.5. This value was determined from factors which cause failure including, material variability, load stresses, geometry, failure analysis, and reliability (Ullman).

4.2.7.1 Drawbar

To constrain the model, the hinge holes position were fixed in all directions, and additionally fixed from rotating about the Y-axis. The hinge points are labelled as a compression only support to represent the hinge pin connection. The tow bar hitch was represented as fixed in the Y-axis and free in the other components and rotations.

4.2.7.1.1 Compression and tension

The drawbar was tested in compression and tension using a load of 1.5 times the weight of the trailer (2,000 kg). A force of 29,430N is placed on the tow hitch mount with the hinge points constrained. This force represents the maximum force on the drawbar during acceleration or braking. Figures 26 and 27 show the deformation and stresses of the drawbar when loaded in tension and compression respectfully.

The maximum stress of the drawbar loaded in tension and compression are 179MPa and 267MPa respectfully. As the maximum stress in the drawbar structure is at the hinge point and is likely that it is a stress singularity due to the set boundary condition as shown be omitted. Peak stresses in regions that are not in potential singularity points do not exceed 80MPa and 100MPa under tension and compression, respectfully. The factor of safety of the stresses is larger than 4.5 for both conditions under peak loading.

The peak deflection of the drawbar loaded in tension and compression is 1.4mm and occurs at the centre of the drawbar structure. Additionally the compressive loading of the drawbar does not exceed the Euler critical buckling load for the member, which is 232kN. The peak deflection is minor and compressive loading does not indicate that the structure will fail during tension or under compression due to buckling.

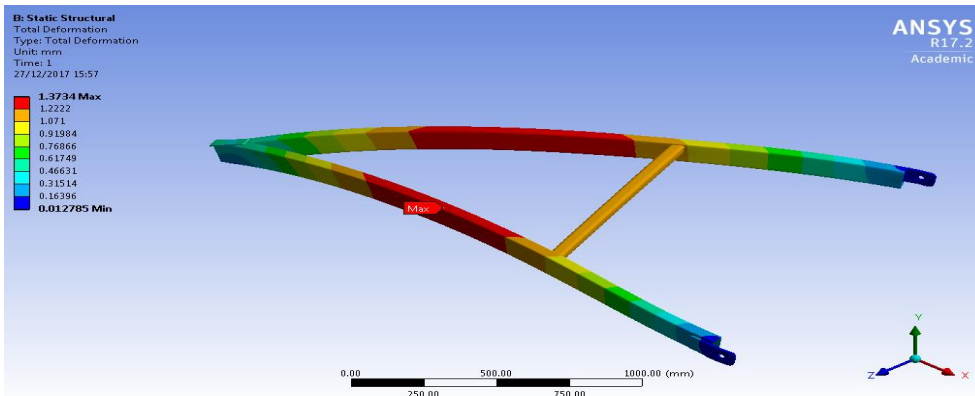
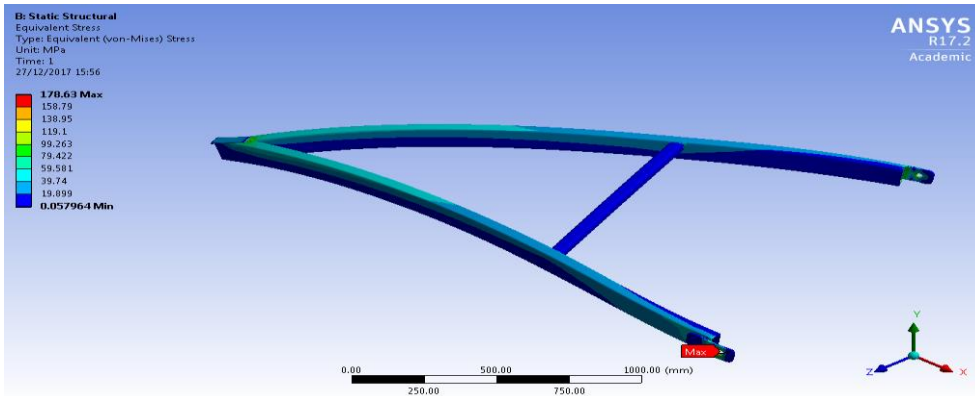

Figure 26 - Drawbar tension loading

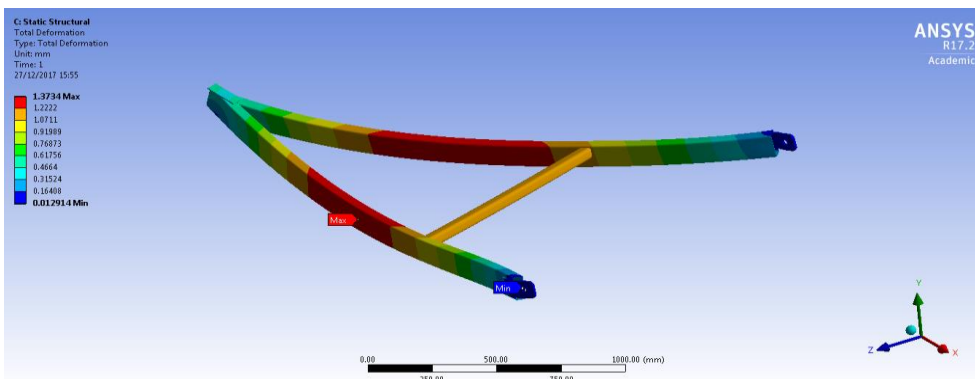
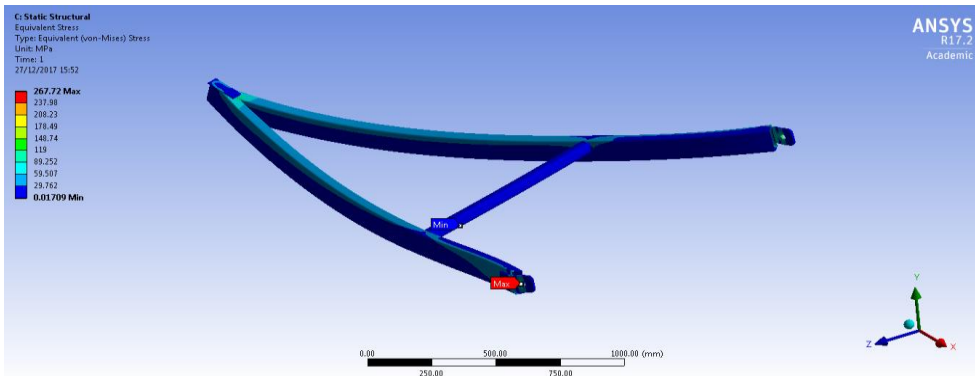

Figure 27 - Drawbar compression loading

4.2.7.1.2 Transverse sideload

The drawbar was tested in with a horizontal transverse sideload using a load of half the weight of the trailer (2,000 kg). A force of 9,810N is placed on the tow hitch mount to the left with the hinge points constrained. This force represents the maximum force on the drawbar during turning. Figure 28 shows the deformation and stresses of the drawbar when loaded with the transverse side load.

The maximum stress of the drawbar loaded in tension and compression is 134MPa. The model maximum stress has a safety factor of 3.3 under the transverse side load respectfully. The maximum stress in the drawbar structure is at the hinge and the hollow member on the left side. The remainder of the stresses within the drawbar structure is in the range of 10MPa to 60MPa. The safety factor for these members exceeds 7.5.

The peak deflection of the drawbar loaded in tension and compression is 1.4mm and occurs at the centre of the drawbar structure. The peak deflection is located on the right side near the centre of the hollow member and does not indicate that the structure is warping in torsion or buckling under compression due to the transverse side load.

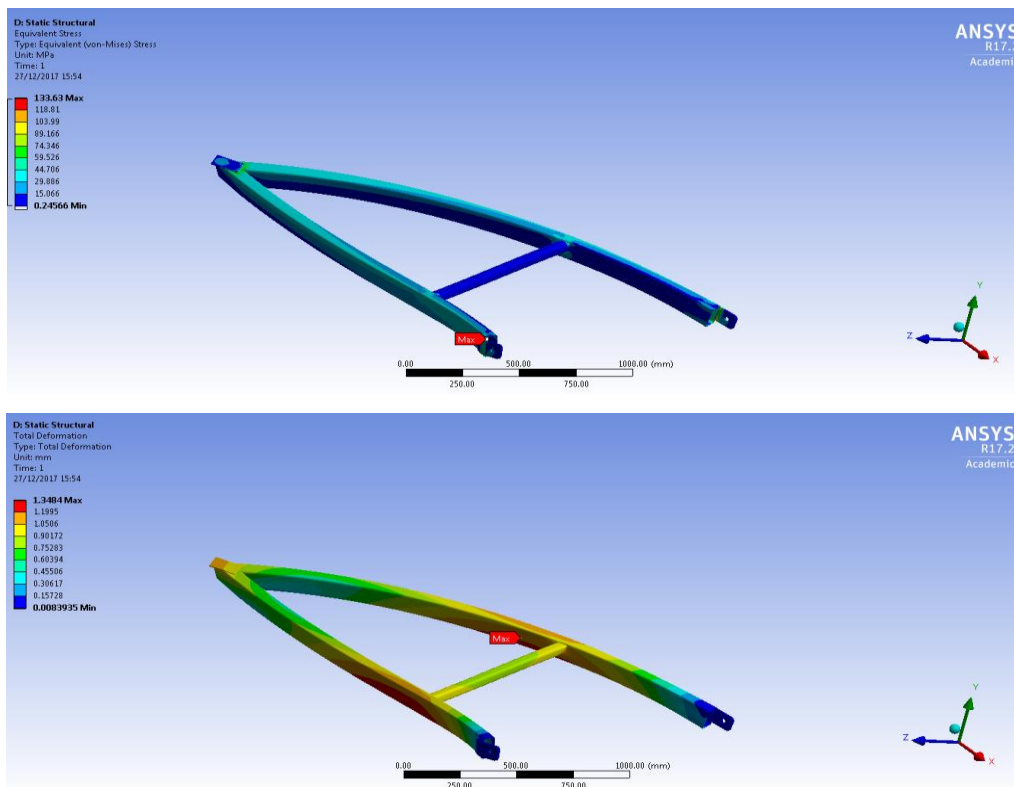

Figure 28 - Drawbar transverse loading

4.2.7.2 Platform

The rotating platform is mounted to the rotating structure via hinges mounted to vertical supports of the inner platform. The sheep straddle between two platforms so the platform supports half of one sheep on one side and half of one sheep on the other. The sheep stands on a perforated sheet, which is supported at the internal support structure of the angle bar. The platform is free to rotate about the hinge points and is supported when it is lowered by a wire rope attached to the centre of the outer angle bar.

The internal structural supports are fully fixed. The hinge contact points were changed to frictionless contact to represent the hinge joint. A load of 80kg is placed on the internal portion of the angle bar to represent the weight of a sheep on the perforated platform. The wire rope mounting point at the centre of the rear platform member is fixed. Figure 29 illustrates the stresses and deformations of the platform as well as the mounting hinge.

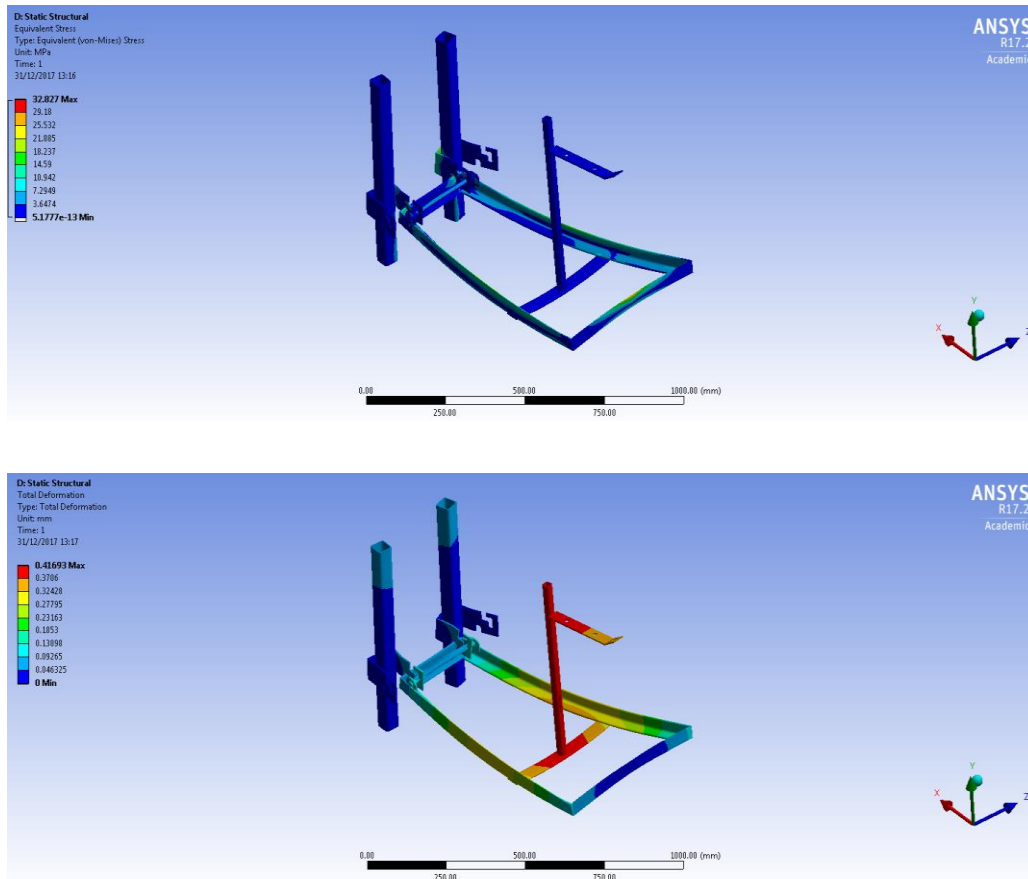

Figure 29 - Platform vertical loading

The maximum stress of the platform is 32.8MPa. The model maximum stress has a safety factor of 10 for this standard loading condition. As the platforms being loading is cyclic the platform structure will experience fatigue. The endurance limit of the material was calculated to be 200MPa was determined from the ultimate strength of the material (Nisbett). The factor of safety for the cyclic failure of the platform is 6. The platform is fully capable of supporting the sheep standing on the platforms and the cyclic loading stresses expected during the operation of the plant.

The supported cantilevered platform has a maximum deflection of 0.42mm. The maximum deflection occurs at the centre of the cross support. Such a small deflection would be unperceivable to the sheep standing on the platform.

4.2.7.3 Trailer chassis

The trailer frame was assessed with the expected loadings of the rotating platform, which is mounted to the outer members of the lower member of the chassis with four platform supports. The standard loading conditions of the rotating platform include a vertical loading of 2000 kg and uneven loading of the platforms producing a moment load of 7,000Nm.

The constraints of the model represented the physical structure of the trailer with supports at the front slew bearing and two rear suspension mounts. The articulated axle is represented via the slew bearing and is fixed in all directions and rotations except being able to rotate about the Y-axis (vertical)

which the slew bearing rotates allowing the turning rotation of the articulating axle. Each of the suspension supports are independently supported and is fixed in the X direction preventing the trailer from moving sideward, Y direction to represent the ground and free to move in the Z direction as motion is unrestricted as the trailer can freely move in this direction. The rear axles are free to rotate about the X-axis.

Figure 30 illustrates the vertical loading model of the trailer frame and Figure 31 shows the vertical and moment loading of the trailer frame. The maximum stress of the chassis model under this loading is 248MPa for the vertical loading and 256MPa for the combined vertical and moment loading. These stresses both occur at the contact between the support brace and angled longitudinal trailer member. This contact is sharp, is likely a stress singularity, and is unlikely to truly represent the stress at this connection point in the fabricated trailer. The greatest stress for the trailer away from potential singularity points for both loading conditions is 110MPa. Hence, the trailer chassis has a factor of safety of 4.1 on the design yeild stress of the members.

The peak deflection of the vertically loaded trailer is 5.4mm and for the combined loaded trailer is 6.2mm. The peak deflections occurred at the centre of the trailer chassis as expected. This deflection is minor and would be acceptable for agricultural use.

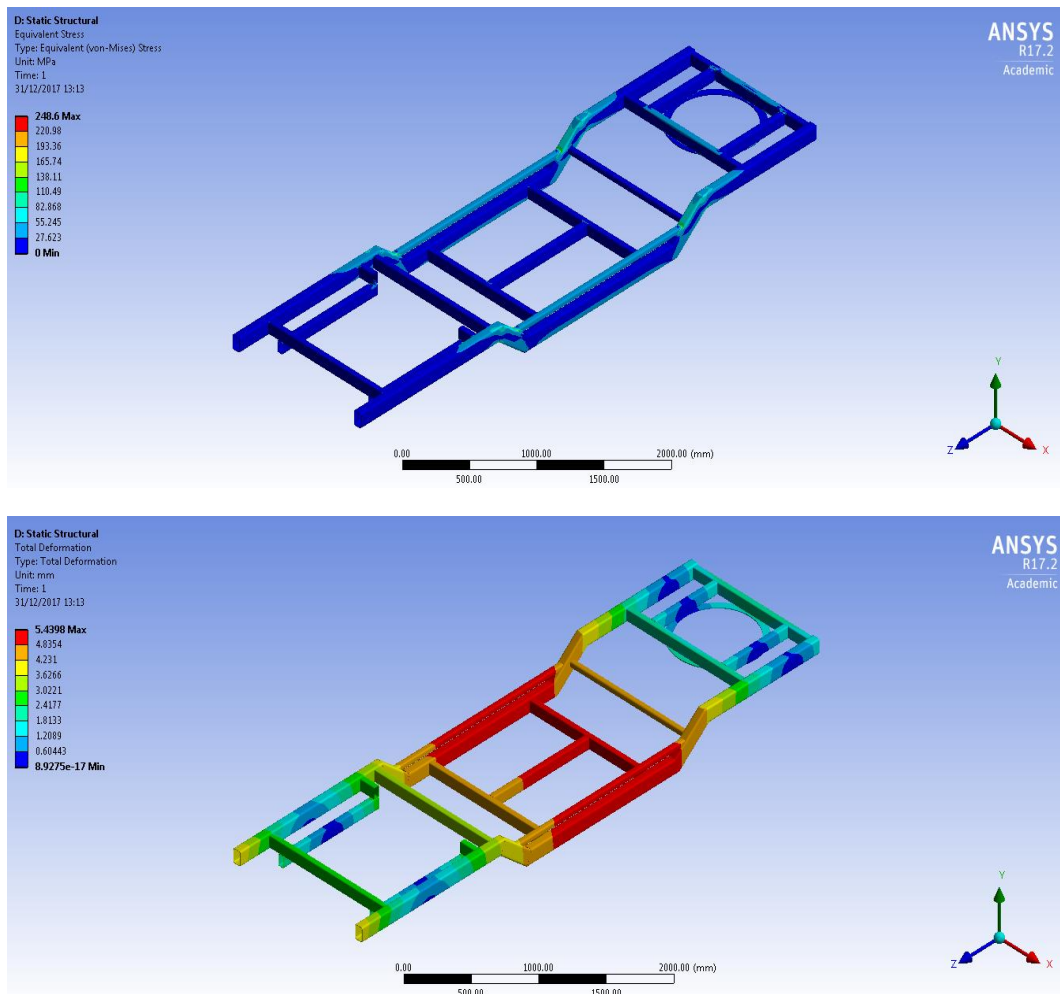

Figure 30 - Trailer frame vertical loading

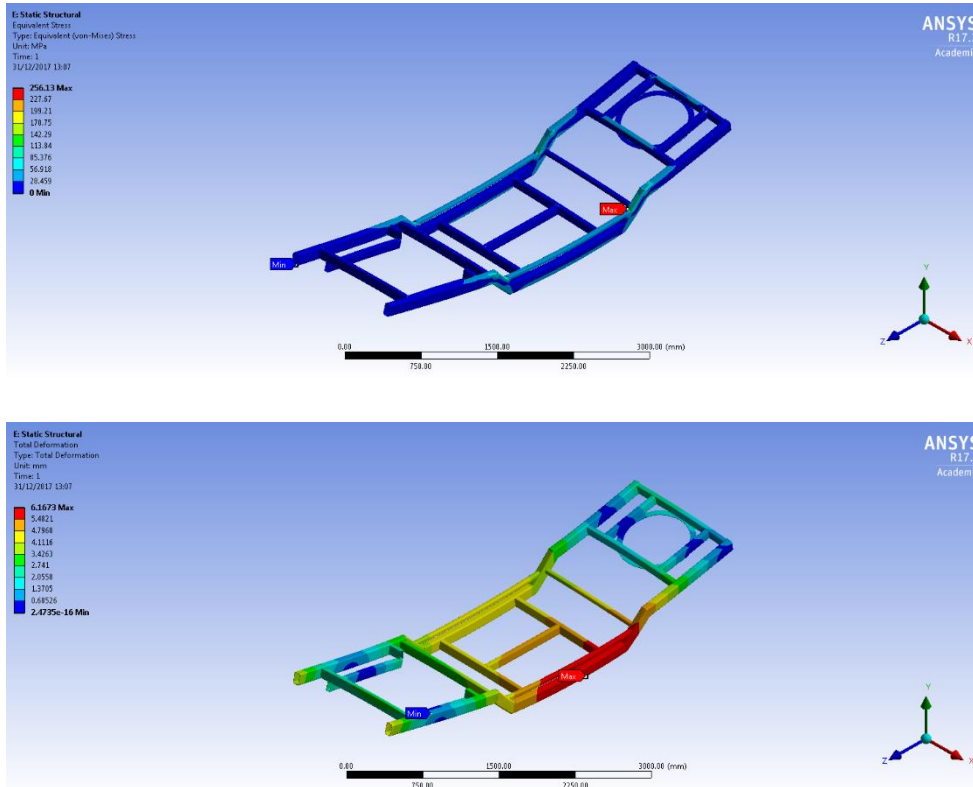

Figure 31 - Trailer frame vertical and moment loading

4.2.8 Validation

Physical validation of the FEA models could not be completed as the trailer is not currently constructed. The trailer structure used members that are typically used in trailers and the stress and deflection profiles in the FEA model seemed reasonable for the loadings, supports, and structural members used. The structures that were modelled all had conservative factors of safety indicating that the designed plant will be fit for purpose.

The model did produce stress singularities at connection points, edges, and surfaces that were somewhat expected at sharp contact edges and surfaces between members. This could have been reduced by adding welds beads between connections removing the sharp corner edges that cause the singularities. The values defined by FEA at these points should not be considered indicative of the true values one might expect in the final plant.

5 Supplementary contributions to the field

The approval for the sale of milk domestically for the portable sheep milking plant required the assessment and evaluation of the current portable 16 unit single aside milking plant compliance with the design and operation of farm dairies operational code (NZCP1) and Risk Management Programme (RMP).

5.1 Design and operation of farm dairies operational code (NZCP1)

NZCP1 is the code of practice for the design and operation of farm dairies in New Zealand. It must be adhered to for the approval of the risk management programme required for the sale of milk domestically. The code encompasses all types of dairies such as cow, sheep and goat. However, it was written primarily for applications of cow dairies as they are the most common in New Zealand.

During the current project, the NZCP1 code was revoked and reinstated with a new NZCP1 by the Ministry of Primary Industries on the 19th of May 2017. Consequently, this occurred after the risk management program was submitted for the current milking plant. However, only one of the requested amendments that were required for the operation of the portable milking plant to comply with the previous NZCP1 are not required in the updated NZCP1. The amendment that was not required was associated with the effluent holding restrictions. The other changes that were made to NZCP1 did not adversely affect the operation of a portable sheep milking plant. Overall the modifications were accepted as part of the risk management program.

5.1.1 Modifications to NZCP1

As part of the project modifications to the NZCP1 that would be required to successfully operate a mobile sheep milking platform were identified and documented. This was undertaken in conjunction with the industry mentor Ian MacDonald. Modifications to the NZCP1 document include amending terms, key quantities, values and practices that are conventional to a cow dairy to be more applicable to an ovine dairy. There were also changes required to enable plant maneuverability and transit. The reasoning behind the modifications and amendments to NZCP1 is included in the amendment document with the modifications. The established amendments apply an equivalent standard or practices that are more applicable to a transportable ovine dairy while retaining the acceptable outcomes of the initial standards and practices in NZCP1.

The modifications were accepted by the Ministry of Primary Industries, as part of the Risk Management Programme and are attached in Appendix B. The verification of the risk management programme including practices such as increasing the milk storage length is being completed currently.

5.2 Risk management Programme (RMP)

Risk management programme (RMP) are required for the sale of milk domestically and is assessed the Ministry of Primary Industries (MPI). The risk management programme of a milking plant is registered to the location of the farm rather than the milking plant. This restricts operating of the milking plant at alternate sites other than the farm the milking plant is registered to. It requires the other farms to be registered with the Ministry of Primary Industries to use the portable milking plant.

5.2.1 Evaluation

Evaluation of the current milking plant and planned processes was completed Stephen Higgs from the Ministry of Primary Industries. The evaluation was required as part of the process of registration of the risk management programme to ensure that the milking plant is compliant with the regulations in NZCP1 and other regulations regarding food safety.

5.2.2 Technical assessment

Verification of the suitability for the sale of raw milk to a processor required the evaluation of the reports generated by the evaluator and farm dairy assessor who analysed the plant and procedures

and reports from the operator. Tony Rumney, Carla Hutchison and Melina Takau-Samson from the Ministry of Primary Industries completed the assessment. After the risk management programme is verified and accepted by the Ministry of Primary Industries the risk management programme will be registered. When the registration is completed, the operator can sell the milk domestically ensuring that the procedures are followed, and the plant is compliant with the regulations.

5.2.3 Verification

Verification is completed on an annual basis or when required to ensure that the milking plant is continuing to be operated within the regulations set out in the risk management programme. The verification is completed after the plant risk management programme has been approved and at least on an annual basis afterwards as detailed in the yearly procedures (section 1.1.1.2.4).

5.3 Validation for milk storage

Validation is a process that allows the testing of the procedures and programmes that are not within the standardised risk management programme or codes of practice. The validation process requires the acceptance by the Ministry of Primary Industries and requires the operators to take and record measurements or observations of the procedures and processes.

The planned and current processor of the milk was only able to take milk of processing on Mondays and Fridays. As the milking is completed once a day, the storage duration of the milk before it is transferred to the processing plant on Friday exceeds the maximum duration length of 3 days (72 hours) by 2 hours as stipulated in the risk management programme. For full compliance with the risk management programme, the milking of the sheep could be completed before or after the milk is transported and transferred to the processor which disrupts the consistency of time milking, which may affect production. To minimise the disruption of this weekly disruption of the milking time, an extension to the milk storage duration length by a few hours and proved by validation to ensure that the milk meets food safety standards and additional conditions set out in the risk management programme. Validation of the extended sheep milk storage is currently being completed.

5.3.1 Farm dairy assessment of current plant

Nick Drinnon from Assure Quality further assessed the milking plant and planned process for its conformance to the regulations of NZCP1 and the risk management programme. The assessment is required for the approval of the risk management programme. The plant was assessed during its construction and before the final submission of the risk management programme.

5.3.2 Approval

Approval was granted for the operation of the plant and the sale of the milk domestically. Validation is also being completed currently for the extended milk storage procedures.

6 Conclusions

The sheep milking plant was optimised with the TRIZ methodology complied with the accepted code of practice and risk management programme for the 16 unit plant. The geometry and strength of the final design of the plant was verified with computer aided design software. This ensured that the milking system, structural components, placement of cleaning systems could fit together in the confined space. The computational model also allowed an FEA stress analysis of key trailer components and the platform. The FEA analysis showed that the proposed plant easily manages the stresses expected in typical operation. Furthermore, the deflection caused by expected loads is lower than acceptable thresholds.

Supplementary work was undertaken during the project that will aid the development of the sheep milk industry in New Zealand. In particular, a new code of practice was developed to specifically enable portable sheep milking and small-scale sheep dairies. This was achieved by noting and adapting the volumes and contingencies that are necessary for large animal dairy, but excessive for medium sized animal dairy. The amendments to the code of practice have been accepted by the MPI and are shown in Appendix B.

6.1 TRIZ methodology

Applying the TRIZ methodology aided in the development of the portable milking plant that is able to milk larger volumes of sheep than currently possible on a mobile plant. The design optimisation used the TRIZ methodology as well as a function map, trimming, discussions with technicians at Read Industrial Ltd and the industrial mentor Ian MacDonald to generate ideas. The systematic approach of the TRIZ design methodology and use of the inventive principals resolved the contradictions identified logically with the function map and trimming process. The contradictions were used to identify the particular inventive principals that provided insight into the mechanics and principals relevant to the problem. As a result, these contradictions quickly aided in the ability to produce designs that removed the contradiction.

6.2 Milking plant

The design of the milking plant and systems was optimised for milking sheep and thus conformed to the physiology and behaviour of sheep. In comparison to dairy cows, sheep have a smaller form factor, low effluent production, and lighter mass into the plant design. Due to the size of sheep, a folding platform and hinge was developed. The folding platform and hinge allow the platforms to fold upwards over each other and allow the milking system to be, within the maximum trailer width. This allowed the trailer to conform to the agricultural vehicle guidelines and means that the trailer can be transported on public roads. The platform was analysed using FEA software to determine the fatigue stresses on the platform and hinge caused by the loading and unloading of sheep on the platform. The analysis determined that the peak stresses of the platform and hinge were 32.8MPa, well below the maximum yield stress by a safety factor of 10 and endurance limit for cyclic loading fatigue by a safety factor of 6.

The components mounted to the rotating platform utilised the small volume in the internal of the platform by adding and removing components, and appropriate sizing and positioning of the systems. The addition of a vacuum pump to the rotating plant removed the necessity of the vacuum transfer system of the centre gland, reducing the complexity of the plant, as only milk and electricity are required to be transferred to and from the rotating system to the stationary trailer platform. The sizing and positioning of the rotating milking plant systems such as the milkline, airline, clusters and dropper tubes, receiver can and vacuum pump were analysed and further developed for milking sheep and operating on a small milking plant. Additionally, the design of the support systems required for operation of the milking plant such as the ventilation system, CIP wash system, jettors, ACR system, and railings were improved and adapted for operation on a rotating platform.

The components not on the rotating plant and supplementary systems were additionally optimised. Systems for transfer and the pre-processing of the milk such as the pump, filter and cooler were positioned for easy access and to reduce the transfer distance for the connection to the milk storage tank on the towing vehicle. The rotary drive system was design to operate on a smaller rotary plant. The drive system uses a single motor and drive wheel mounted on a spring loaded sliding mechanism and two spring-loaded backing wheels to ensure contact between the drive wheel and the rail. The effluent and CIP tank capacities were increased to hold up to 300 litres and provide the ability to separate and store the waste streams for separate disposal. The allowance for separate disposal may be required to meet regulations for disposal that vary between regional authorities. Additionally, a califont hot water system was introduced to to provide hot water on demand for the CIP wash and allows the entire milking system to be transported with a truck and trailer unit.

6.3 Trailer design

The trailer chassis provides a stable working platform with the axles at the front and rear of the trailer and allows the plant to operate without the towing vehicle if required. The trailer can be raised by outrigger hydraulic or screw jacks with a stabilising base allowing the trailer to operate on uneven ground or raising the platform for tall operators to work at an ergonomic height. The lowered area of the chassis allows the rotating platform to be 900mm above the ground and provide sufficient area for the milking plant systems on the rotating and stationary platforms.

The trailer design utilised an articulating axle for weight distribution and manoeuvrability. This significantly reduced the weight that the trailer transfers to the towing vehicle via the towing hitch. As a result, the trailer design is not compliant fully with the light trailer standard due to the lack of hitch weight. Lack of hitch weight has been reported to lead to instability in transit. Hence, compliance must be achieved by either adding weight to the drawbar, meeting the specification, or completing a verification test after the trailer is constructed. Finite element analysis was undertaken on the drawbar confirming that the stresses and deformations were within acceptable limits and compliant with the light trailer standards. FEA analysis confirmed that the drawbar strength exceeds limits for compliance to the light trailer standard (NZS 5467)

Additionally, the stresses and deformation of the trailer chassis and platform were examined with the expected loads for the structures and sheep. The stresses and deformations of the chassis and platform were fully capable of withstanding the loads applied. The chassis was analysed under the expected loading of the platform including a vertical and vertical and moment loading. This analysis occurred stress singularities caused by the contact between two members. However, the maximum stresses that implied a safety factor of 4.1. Minor deflection of the structure under the applied loads of 6.2mm was deemed to be within acceptable limits.

6.4 Summary

Overall, the project developed a portable milking plant that will be more productive than the previous milking plant while retaining the footprint of a trailer and able to be transported as an agricultural trailer on the open road. The development of this portable sheep milking plant will aid in the development of the sheep milking industry in New Zealand, which is expected to develop in to billion-dollar industry by 2025. Due to the small scale of the plant, it will allow farmers to convert their flock to dairy sheep partially without the major investment of a permanent structure for a milking.

7 Potential further work

During the project, further work was discovered that would aid the development of the sheep milking industry in New Zealand. This includes further optimisation of the milking plant, further optimisation of dairy sheep genetics and the creation of value added sheep milk products.

7.1 Maximising the utilisation of the milking plant

The rotary arrangement allows some differing challenges and opportunities to the single aside systems. Each challenge must be addressed to increase sheep milking efficiency. In particular:

- Identifying the optimal rotation time
- Managing problematic sheep as you cannot visually assess the sheep throughout milking
- Optimal treatment of slow milking sheep

7.2 Sheep genetics

There are a number of dairy sheep breeders in New Zealand. Dairy sheep breeder will target and improve the sheep milk yield, yield rate, milking period, lactation period, and resistance to disease and resilience to environmental conditions. These factors will increase the efficiency of the dairy sheep and contribute to the development of the industry.

7.3 Value-added products

The development of the sheep milk industry will be supported by the production and marketing of the development of value added sheep milk products. As the portable milking plant was developed for small-scale sheep milking, the processing of the sheep milk will have to be processed in small-scale cottage industries or potentially collaboratively in a mid-scale milk processing plant.

The economic viability of these sheep milk-processing plants must be determined to assess the viability. The milking plant should be capable of processing increased sheep milk volumes as the industry and consumer demand grows. The higher fat content of the sheep milk develops a 'creamier' milk product. Hence, a strong consumer demand is expected.

The milk produced from the portable milking plant would suit a small-scale processing plant to produce sheep milk products to be sold locally or nationally. The target market sheep milk products for New Zealand identified by Griffiths include fresh bottled milk (raw, organic, or pasteurised), whey protein, cheese, yoghurt, butter and ice-cream (Griffiths). These products can be produced on a small-scale plant efficiently, with the exception of whey protein, with the expected volumes that are produced on a portable sheep milking plant.

If larger volumes of milk are able to be a midscale or larger milk processing plant could be more effective. The use of a larger scale milking plant would allow UHT milk, milk powder and milk powder derivatives such as infant formula and beauty products to be produced efficiently. Other value added products such as fresh bottled milk (raw, organic, or pasteurised), whey protein, cheese, yoghurt, butter and ice-cream could also be efficiently be produced. However, certainty for the supply and demand is required for the continued collaboration between the farmers for economic viability of mid-scale milk processing plants.

8 References

(MPTA), NZMPTA 2013, 'Milk Machine Testing Standards'.

Acin, M 2015, *Stress singularities, stress concentrations and mesh convergence*, viewed, <Stress singularities, stress concentrations and mesh convergence.>.

'Agricultural vehicles guide' 2017, ed. NT Agency.

ALLISON, AJ 1995, 'Importing a sheep which offers more - the East Friesian', *Proceedings of the New Zealand Society of Animal Production 1995*, vol. 55

Arciszewski, T 2016, 'TRIZ', in *Inventive Engineering*, CRC Press, pp. 285-339.

Arthur Stubbs, Gaille Abud, Roberta Bencini 2009, *Dairy Sheep Manual - Farm Management Guidelines*, Rural Industries Research and Development Corporation.

Authority, NZFS 2009, 'Heat Treatment Code of Practice'.

Balthazar, CF, Pimentel, TC, Ferrão, LL, Almada, CN, Santillo, A, Albenzio, M, Mollakhalili, N, Mortazavian, AM, Nascimento, JS, Silva, MC, Freitas, MQ, Sant'Ana, AS, Granato, D & Cruz, AG 2017, 'Sheep Milk: Physicochemical Characteristics and Relevance for Functional Food Development', *Comprehensive Reviews in Food Science and Food Safety*, vol. 16, no. 2, pp. 247-262.

Barnao, C 2008, 'DPC2: Animal Products (Dairy) Approved Criteria for Farm Dairies', ed. NZFS Authority.

Bennett, HJ 2015, 'Ever wondered how milk becomes cheese?', *The Washington Post*,

Boyd, K 2016, *Viability of establishing a sheep dairy platform on North Canterbury dry land*,

Britannica, TEOE, 'Merino', in *Encyclopædia Britannica*, August 02, 2013.

Buddies, S 2012, 'Semisolid Science: Growing Yogurt', *Scientific American*

Chris Smith, BLaNW, 'Effluent management on a dairy sheep farm'. AgResearch.

Collins 2008, 'New Zealand Dictionary'. HarperCollins.

Country, T 2017, 'Growing sheep milk industry bolstered by science

', *NZ Herald*,

D N Akam, FHD, A J Quick 1989, 'Milking, milk production hygiene and udder health', vol. 2017. FOOD AND AGRICULTURE ORGANIZATION OF THE UNITED NATIONS.

DairyNZ, *Planting Waterways*, viewed 07/12/17, <<https://www.dairynz.co.nz/environment/waterways/planting-waterways/>>.

Douglas J. Reinemann, GAM 1995, 'Prediction of milkline fill and transition from stratified to slug flow', *Transactions of the ASAE*, vol. 38, no. 3, pp. 975-978.

Downie-Melrose, K 2014, *A Bio-economic Feasibility Study of Sheep Dairy Systems in Canterbury* Lincoln University,

Fonterra 2010, *Dairy Diary*.

Gadd, K 2011, *TRIZ For Engineers: Enabling Inventive Problem Solving*, John Wiley & Sons, Ltd.

Graham Butcher, Dr. Riza Kibar, Russel J Laurie, Shane Lodge , Prof. Dorian Garrick, Louise Gosling, Neil & Gill Potter 1997, *Sheep Dairying in New Zealand* The Sheep Dairy Association of New Zealand.

Gray, J 2017, 'Dairy gets its mojo back after Fonterra ups milk price forecast to \$6.15/kg', *NZ Herald*,

Griffiths, L 2015, *Business Plan for the NZ Sheep Dairy Industry*, Nuffield New Zealand, New Zealand

Heiler, T 2008, 'Irrigation and drainage - Irrigation and the environment', in *Te Ara - the Encyclopedia of New Zealand*.

Herud, G 2012, 'The Mobile Milking System', in *Milking on the Moove*, vol. 2017.

Ice Cream Production, viewed, <<http://www.milkfacts.info/Milk%20Processing/Ice%20Cream%20Production.htm>>.

John Ballingall, DP 2017, *Dairy trade's economic contribution to New Zealand* New Zealand Institute of Economic Research

Lees, I 2015, *Strategies to establish an internationally competitive sheep dairy industry in New Zealand* European University,

- Lenzi, O 2013, *Why you should test the lactic acid in milk*, viewed 19/12/17, <<https://www.cdrfoodlab.com/news-topics/lactic-acid-milk-test/>>.
- Mackle, DT 2017, 'Dairy NZ fronts up', in *Country Life*. Radio New Zealand.
- Major loss in ducts, tubes and pipes*, viewed 30/12/17, <https://www.engineeringtoolbox.com/major-loss-ducts-tubes-d_459.html>.
- Manch, T 2017, 'NZ's waning sheep flock: Has our pastoral identity finally jumped the fence?', *Stuff*,
- Meshing in Mechanical* 2010, viewed, <http://inside.mines.edu/~apetrell/ENME442/Labs/1301_ENME442_lab3.pdf>.
- MPI, *Selling raw drinking milk to consumers*, viewed 07/12/17, <<http://www.mpi.govt.nz/growing-and-harvesting/dairy/selling-raw-milk-to-consumers/>>.
- N Watkins, RL, C Smith and R Monaghan 2016a, '#7 Effluent management on a dairy sheep farm', *Proceedings of the New Zealand Society of Animal Production*, vol. 76, pp. 199-204.
- N Watkins, RL, C Smith and R Monaghan 2016b, 'Effluent management on a dairy sheep farm', *Proceedings of the New Zealand Society of Animal Production*, vol. 76
- Nisbett, RGBaJK 2015, *Shigley's Mechanical Engineering Design*, Tenth edn, McGraw Hill.
- NZ, D, 'Automatic milking systems', viewed, <https://www.dairynz.co.nz/media/581332/automatic_milking_systems_booklet.pdf>.
- NZ, D, *Cleaning systems*, viewed, <<https://www.dairynz.co.nz/milking/the-milking-plant/plant-cleaning-systems/>>.
- NZ, D, *MaxT -Herringbone*, viewed 20/2, <<https://www.dairynz.co.nz/milking/herringbone/maxt-in-the-herringbone/>>.
- NZ, D, *Operating a rotary*, viewed, <<https://www.dairynz.co.nz/milking/rotary/operating-a-rotary/>>.
- NZ, D, *Rotary*, viewed, <<https://www.dairynz.co.nz/milking/rotary>>.
- NZ, R 2017, 'Water tax negligible for most dairy farms - industry figures', viewed, <<http://www.radionz.co.nz/news/election-2017/339524/water-tax-negligible-for-most-dairy-farms-industry-figures>>.
- NZSheepmilkco, *Nutritional - FAQs*, viewed 7/12/17, <<https://nzsheepmilk.co.nz/nutritional-faqs/>>.

'Operational Code: NZCP1: Design and Operation of Farm Dairies' 2015, ed. MfP Industries. New Zealand Government, Wellington.

Peden, HSaR 2015, 'Sheep farming - New Zealand sheep breeds', in *Te Ara - the Encyclopedia of New Zealand*.

'Physico-chemical characteristics of goat and sheep milk' Y.W. Park, M. Juarez, M. Ramos, G.F.W. Haenlein, *Small Ruminant Research*, vol. 68, pp. 88-113.

The Process Cheese Making 1,2,3, viewed 21/12/17, <<http://www.cheesemaking.com/learn/cheese-making-1-2-3/the-process.html>>.

'Product Catalogue Steel' 2017, ed. Sa Tube.

'Requirements for the Construction of New Farm Dairies' 2013, ed. AsureQuality.

'Risk Management Programme (RMP) Template for Farm Dairies - Domestic Supply' 2015, ed. MoP Industries.

Savransky, SD 2000, *Engineering of Creativity - Introduction to TRIZ Methodology of Inventive Problem Solving*, CRC Press.

Scrimgeour, HSaF, 'Dairying and dairy products - Dairy cattle breeds', in *Te Ara - the Encyclopedia of New Zealand*.

Sheep, N, 'BORDER LEICESTER', 27/11/2017.

Sheep Yogurt, viewed 21/12/17, <<http://www.milkingsheep.com/sheep-milk-recipes/sheep-yogurt/>>.

Stuff 2016, 'Official approval for sheep milking breed', *Stuff*,

SW Peterson, CP 2015, 'The sheep dairy industry in New Zealand: a review', *Proceedings of the New Zealand Society of Animal Production*, vol. 75, pp. 119-126.

Temperature control, viewed 19/12/17, <<http://www.foodstandards.govt.nz/consumer/safety/faqsafety/pages/foodsafetyfactsheet/s/charitiesandcommunityorganisationsfactsheets/temperaturecontrolma1477.aspx>>.

TVNZ 2017, *Hyundai Country Calendar – Season 2017, Episode 36*.

Ullman, DG 1992, *The Mechanical Design Process*, McGraw-Hill.

Whatford, L 2016, *Sheep Mastitis - Udder and teat conformation*, viewed 19/12/17.

'Whole Sheep Milk Powder'. Blue River.

Wolford, D, *Milk Showdown: Cow vs Sheep vs Goat - Which is best?*, viewed, <<https://www.weedemandreap.com/milk-showdown-cow-sheep-goat/>>.

Young, C 2017, 'Dairy cows putting Selwyn drinking water at risk, residents told', *Radio New Zealand*,

Zealand, SN 1993, 'NZS 5467:1993', in *Code of Practice for Light Trailers*.

9 Appendix

9.1 A - Function Map

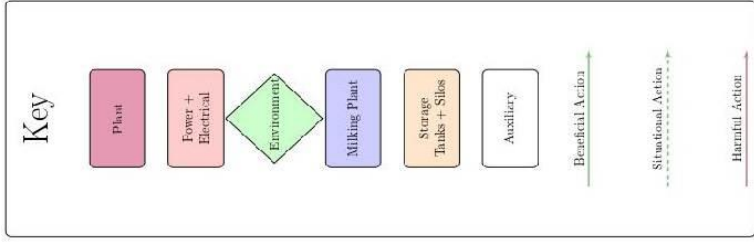
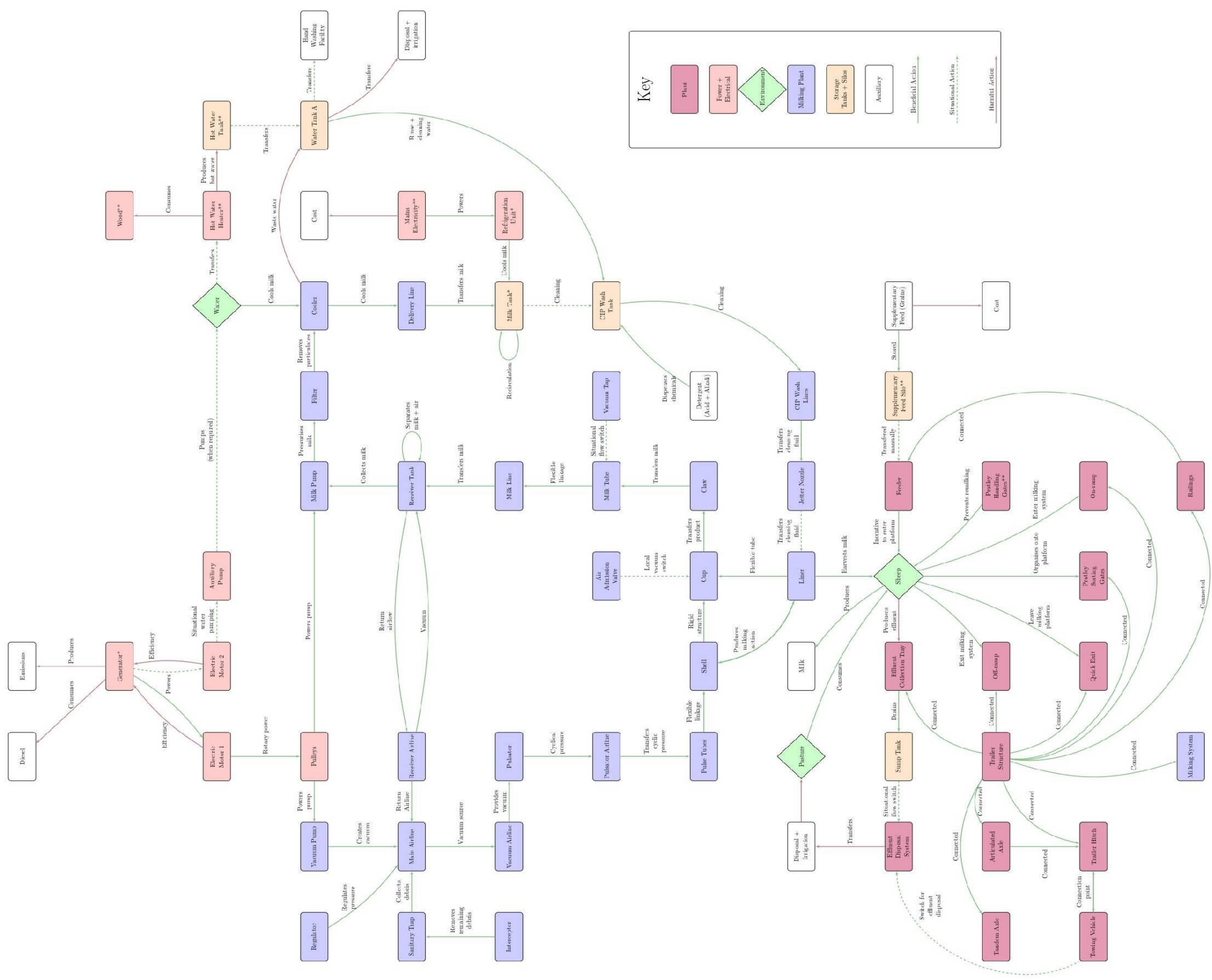

9.2 B - Modifications to NZCP1

Amendments made to NZCP1 allow the operation of a portable sheep milking platform.

Red highlights are for redactions

Yellow highlights are for additions

3.5 (2) Tanker collection

Replace 'The yards must be sited to facilitate tanker collection. For specific requirements the dairy company and local authority are to be consulted.'

With 'Transport from milking site to existing infrastructure must be suitable for ute/trailer vehicles.'

Reason for change: As the farm is producing less milk than a conventional dairy farm, large milk tankers will not be required to transport the milk to the dairy company. Instead small-scale milk transport vehicle that does not require a heavy traffic entranceway and tanker road to transport the milk from the milking platform to the dairy company for further processing.

3.6 (1k) Tanker roadway

Replace: 'on newly converted dairy farms, stock must not be able to cross the tanker roadway.'

With 'Tanker roadways for sheep dairy should be well maintained and effluent managed to minimise contamination being carried to the dairy factory via the tanker.'

Reason for change: Sheep generate less effluent in transit than cows, and thus, introducing the same level of constraint in ovine dairy is not necessary. The main access way to the farm and the route that the milk transport vehicles will take may rarely have stock transported along it. If this does occur the milk transport should have to use the raceway after the stock have been transported along it, the vehicles should leave the property in a clean and hygienic state to minimise contamination that the milk factory.

3.8 (Table 1) Drainage pad, effluent storage, supplementary feed

Add to 'Supplementary feed storage'

'Supplementary feed storage larger than 5m³'

Reason for change: No volume of storage stated in NZCP1, with a small amount of supplementary feed storage less than 5m³ vermin and other potential contamination problems will be minimal provided the storage is maintained in a safe and hygienic state.

3.8 Note Drainage Pad, effluent storage, supplementary feed

Add to 'In addition, the storage vessel should be at least 10 m from the milk vat.'

With 'In addition, the storage vessel larger than 5m³ should be at least 10 m from the milk vat.'

Reason for change: To comply with change in Table 1

4.1 (2) Farm races

Removal of "Farm races must be made of concrete for a distance of 10 m from the milk receiving and milk storage areas, and edges of the pit or milking platform. If these areas are not maintained in a safe and hygienic condition the amount of concrete race required may be extended."

Reason for removal: For a portable milking platform, a farm race of concrete is unfeasible and unnecessary. If the ground surrounding the entranceway and exit is in a clean and tidy state and not muddy from the sheep treading on the land a concrete farm race is unnecessary. As the siting of the milking platform is going to change, the raceway will have time to recover from the temporary placement of the sheep on the raceway during milking times.

4.2 Kerbing

Removal of section

Reason for change: Kerbing is unnecessary for the portable milking trailer. Initially the perforated platform floor on top of an impervious collection tray which drains to a sump is able to capture unwanted mud, urine, faecal material and dispose of it into the sump. Secondly, sheep produce less effluent than cows requiring less and lower pressure water to clean the effluent and mud from the tray. Subsequently, as kerbing is required to entrap the effluent while cleaning, due to the perforated floor, (the water will pass through and be collected on the tray below) kerbing is unnecessary to entrap the spray from the water stream.

4.3 (5) Effluent Drains and Sumps

Removal of 'Sumps must be made of concrete or another impervious material and must be designed to be easily cleaned. **Sumps must not be located within 10 m of the milking, milk receiving and milk storage areas.** The effluent is to be pumped away on a daily basis or piped to effluent ponds.'

To 'Sumps must be made of concrete or another impervious material and must be designed to be easily cleaned. The effluent is to be pumped away on a daily basis or piped to effluent ponds.'

Reason for change: As the sump will be attached to the milking platform, it will unfeasible for it to be further than 10m from the milking shed. The placement of the sump is furthest from the milk storage area and is underneath the milking areas. The sump is fully enclosed only allowing effluent to enter from the collection tray below the milking area and the effluent is disposed onto the property daily with the consent of the local authority. The sheep are not able to be in contact with the effluent water and the trailer has sufficient storage and is able to hold 125L in the tank and 500L in the drainage tray.

4.3 (6 -> 11) Effluent Drains and Sumps

Removal of clauses 6 -> 11

Reason for change: The sump allows the collection of the effluent and CIP wash into a sealed system. As the effluent collection system does not use a drainage pad, or a sand trap these clauses are not necessary.

4.4 (1) Drainage outfall and effluent discharges

Addition to 'Drainage outfalls or effluent discharges from all livestock, including pigs and silage pit run-off, must not be sited closer than 45 m from the milking, milk receiving and milk storage areas, and the water supply. This includes effluent ponds, treatment ditches and places where effluent is sprayed on to the land.'

To 'Drainage outfalls or effluent discharges from all livestock, including pigs and silage pit run-off, must not be sited closer than 45 m from the milking, milk receiving and milk storage areas, and the water supply. This includes effluent ponds, treatment ditches and places where effluent is sprayed on to the land. **Exception: when effluent is disposed of from a portable milking system provided that the vehicle is discharging the effluent (collected from the milking platform) from the rear of the moving vehicle provided it has been consented by the local authority.'**

Reason for change: As the portable milking trailer will be depositing the effluent on the property from the rear of the trailer after milking has ceased. There will be negligible contamination on the milking platform

4.13 (3) Location of tank for milk not intended for supply

Addition to 'Milk not intended for supply that is stored within 20 m of the farm dairy must be stored in a suitable vessel that is sealed and on a concrete pad capable of being cleaned. Drainage from the pad must be connected to the dairy effluent system.'

With 'Milk not intended for supply that is stored within 20 m of the farm dairy must be stored in a suitable vessel that is sealed and on a concrete pad **or impervious material** capable of being cleaned. Drainage from the pad must be connected to the dairy effluent system, **or secondary effluent tank on the vehicle.**'

Reason for change: A concrete pad on a portable milk vat would be unfeasible. If the vessel were placed on an impervious material such as steel, it would provide sufficient base for the vessel that can be cleaned.

4.14 (2) Fuel burning engines

Addition to 'Fuel, smoke and exhausts can lead to milk contamination by odours and airborne matter.'

To 'Fuel, smoke and exhausts can lead to milk contamination by odours and airborne matter. **An exhaust system that minimises exhaust in the dairy area to be used where possible.**'

Reason for change: There was no recommendation to minimise exhaust smoke where possible

5.1 (1g) Supply of milk, acidity level of sheep milk

Adjustment of values adequate for sheep 'milk with an acidity level of **0.18%** or higher;'

To 'milk with an acidity level **(lactic acid %) higher than 0.26% or pH less than 6.4;**'

Reason for change: Sheep milk has different properties than cows milk. This was sourced from the Sheep Dairying in New Zealand Guidebook, and scientific journal article 'Physico-chemical characteristics of goat and sheep milk' by Y.W. Park et al

5.2.6 (3) Quarter milkers transferable to sheep milking

Remove **'Quarter milkers must not be used to segregate milk from treated and or diseased milking animals. If treated, milk must be withheld from all quarters, even if not all quarters are treated.'**

Replace with **'Segregated milking equipment, must not be used to segregate milk from udder partitions from treated or diseased milking animals, If treated, milk must be withheld from the milking animal, even if not all udder partitions are treated.'**

Reason for change: Quarter milkers are not used on sheep. Changed to make sense for twin cup systems and other milking systems

5.3 Bobby calf collection

Remove section

Reasons for change: Not required on a sheep dairy farm

5.4 (2) Colostrum

Remove

Reasons for change: Not required for sheep dairy

5.4 (3) Colostrum

Transfer of terms from 'Records must be kept of the **calving** date and date animals enter the milking herd.'

To 'Records must be kept of the **lambing** date and date animals enter the milking herd.'

Reasons for change: Change of terms from calving to lamb

5.21.2 Tail Docking

Remove section

Reason for change: Not required as tail docking is commonplace and required for sheep

5.21.4 Bobby Calf Collection

Remove section

Reasons for change: not required for sheep dairy

6.3 Water requirements

Adjustment of values adequate for sheep

'As a guide, summer cold water requirements are:

- a. drinking – **70 L** per milking animal per day;
- b. premises and plant sanitation (including milk cooling) – **70 L** per milking animal per day; and
- c. total per milking animal each day – **140 L** per milking animal per day.'

To 'As a guide, summer cold water requirements are:

- a. drinking – **10 L** per milking animal per day;
- b. premises and plant sanitation (including milk cooling) – **10-20 L** per milking animal per day; and
- c. total per milking animal each day – **20-30 L** per milking animal per day.'

Reasons for change: Sheep require different water requirements than cows for cleaning. This allows for cooling of the milk (3x the milk volume), and cleaning water (CIP wash (approximately 300L of water for 300 sheep))

6.7 (2) Milk Plant Cleaning

Adjustment of values adequate for sheep

'Typically a minimum volume of **5-10 L** of suitable water per cluster is required to rinse the milking plant effectively, but advice should be obtained from the detergent company representative for the specific cleaning products in use. The rinse water volume must be recorded in the documented cleaning procedures required under clause 6.4 Cleaning System.'

To 'Typically a minimum volume of **2-5 L** of suitable water per cluster is required to rinse the milking plant effectively, but advice should be obtained from the detergent company representative for the specific cleaning products in use. The rinse water volume must be recorded in the documented cleaning procedures required under clause 6.4 Cleaning System.'

Reason for change: Adjustment of values for sheep milking systems

10.6 Filter Sizing

Transfer of terms from 'Filters must be sized at a minimum of 6.0 cm²/cow effective filtering area. If the effective filtering area is unknown then it can be estimated using the formula:'

'Filters must be sized at a minimum of 6.0 cm²/sheep effective filtering area. If the effective filtering area is unknown then it can be estimated using the formula:'

Reason for change: Change of terms

13.3 Minimum Quantities of Cold Water Required for Cleaning Plant and Vats

Adjustment of values adequate for sheep milking systems

'Enough cold water is needed prior to cleaning to flush milk residues from the plant to the stage where the discharge liquid runs clear. In addition, sufficient cold water must be available to rinse cleaning chemicals from the plant following cleaning or sanitising. Usually a total of 10 - 20 L per cluster (product flush and cleaning) and 4% of the vat volume is sufficient, but a higher volume may be required for larger vats.'

To 'Enough cold water is needed prior to cleaning to flush milk residues from the plant to the stage where the discharge liquid runs clear. In addition, sufficient cold water must be available to rinse cleaning chemicals from the plant following cleaning or sanitising. Usually a total of 5 - 10 L per cluster (product flush and cleaning) and 4% of the vat volume is sufficient, but a higher volume may be required for larger vats.'

Reason for change: Adjustment of values for sheep milking systems

13.4.1 Water Heaters

Adjustment of values adequate for sheep milking systems 'The minimum quantity of hot water available must be 10L per set of cups and 2% of the vat volume with a minimum volume for vats of 120 L.'

To 'The minimum quantity of hot water available must be 5L per set of cups and 2% of the vat volume with a minimum volume for vats of 80L.'

Reason for change: Adjustment of values for sheep milking systems

13.4.2 Cleaning Systems for Standard Milking Machines

Adjustment of values adequate for sheep milking systems

'New farm dairies must have recirculation cleaning systems.

jetter and bucket systems – allow a minimum of 10L/cluster of hot and cold water, at a flow rate of not less than 3 litres/minute through each jetter.'

To 'New farm dairies must have recirculation cleaning systems.

jetter and bucket systems – allow a minimum of 5 L/cluster of hot and cold water, at a flow rate of not less than 3 litres/minute through each jetter.'

Reason for change: Adjustment of values for sheep milking systems