

Low Effort Patient Handling Devices

A thesis submitted in partial fulfilment
of the requirements for the Degree of
Master of Mechanical Engineering
in the University of Canterbury

by A. D. Waymouth

University of Canterbury

2014

Abstract

With an aging population there is a growing need to assist people with disabilities. Particularly crucial is assisting people who cannot stand between positions necessary for everyday living, such as from a wheelchair to the toilet. It is unsafe to transfer people with direct manual techniques, thus a patient handling device is required.

To reduce the burden on the healthcare system it is beneficial for disabled people to be cared for in-home. Many in-home caregivers may be physically impaired, thus patient handling devices for this use must require as little effort as possible.

This thesis found that existing manual patient handling devices contained significant weaknesses when used for in-home care and there is potential to improve upon them. Expert interviews, computer modelling and physical models were used to develop a novel patient handling device which addresses these identified weaknesses. A reduction in the number of operator tasks, operation time and operation force was achieved.

A method of supporting the patient solely by their upper body is required by the novel patient handling device, though an acceptable way of incorporating this has yet to be achieved. Testing of an upper body enclosure support revealed that a person may be supported by their lower thorax without substantial clamping or physical effort from the patient. Such a support has potential to be developed into an acceptable solution. Further development and testing in variable conditions encountered during practical patient handling is required.

Contents

1	Introduction	1
1.1	Patient Care Statistics.....	3
1.2	Caregiver Injuries.....	5
1.3	Guidelines.....	7
2	Patient Handling Device literature review	10
2.1	Study 1.....	10
2.1.1	Method.....	11
2.1.2	Relevant Results & Discussion.....	12
2.2	Study 2.....	14
2.2.1	Method.....	15
2.2.2	Relevant results.....	15
2.3	Study 3.....	16
2.3.1	Method.....	16
2.3.2	Relevant results.....	17
2.4	Study 4.....	18
2.4.1	Method.....	18
2.4.2	Relevant results.....	19
2.5	Standards.....	22
3	Patient Characteristics.....	26
3.1	Common Causes of Disability.....	26
3.2	Range of Motion.....	27
3.3	Pain.....	29
3.4	Injury	31
4	Patient handling device review.....	35
4.1	Mechanism.....	35
4.1.1	Mobile Sling Hoist.....	36
4.1.2	Standing Hoist	37
4.1.3	Easy Pivot	38
4.1.4	Whole Body Pivot.....	39

4.1.5	Little Blue.....	40
4.1.6	Multi-Bar Linkage	41
4.1.7	Rocking Chair.....	42
4.1.8	Mechanism Comparison.....	43
4.2	Support.....	45
4.2.1	Sling.....	45
4.2.2	Belt Support.....	47
4.2.3	SureHands Support.....	48
4.2.4	Chest Pad.....	49
4.2.5	Under Arm.....	50
4.2.6	Chest Clamp.....	51
4.2.7	Support Comparison	52
5	Mechanism Development.....	54
5.1	Modelling of Existing Devices.....	55
5.2	Prototype Review	59
5.3	Concept Generation	61
5.4	Concept Modelling	63
5.5	Design Overview.....	71
5.6	Operation	73
6	Mechanism Testing.....	74
6.1	Apparatus.....	76
6.2	Testing Process.....	79
6.3	Analysis Method.....	80
6.4	Results	83
6.4.1	Handling Task Reduction	83
6.4.2	Operation Force Reduction	85
6.4.3	Model Efficacy.....	87
6.4.4	Additional Observations.....	89
6.5	Conclusions.....	91
6.5.1	Handling Task Reduction	91
6.5.2	Operation Force Reduction	92
6.5.3	Model Efficacy.....	93
6.5.4	Additional Observations.....	94

6.6	Recommendations	95
6.6.1	Testing and Measurement	95
6.6.2	Mechanism	96
7	Support Development	97
7.1	Prototype Review	98
7.2	Concept	99
7.3	Construction	100
8	Support Testing.....	101
8.1	First Test	101
8.2	Second Test	103
8.3	Third Test.....	105
8.4	Discussion	107
9	Conclusion.....	109
10	Recommendations for Further Research	111
11	References.....	112
Appendix A	Patient Handling Expert Interview - Summary	115

List of Figures

Figure 1-1 Estimated proportions of hoist need type.....	3
Figure 1-2 Lifting and lowering weight limits	5
Figure 1-3 Risk management flow chart.....	8
Figure 1-4 Example client profile form	9
Figure 2-1 Studied patient handling techniques: Under arm lift (left), pulling technique (centre) and hoist assisted lift (right)	10
Figure 2-2 Six strap sling with adjustable spreader bar	14
Figure 2-3 Rescue style belt lift.....	16
Figure 2-4 Elevate and Transfer Vehicle	18
Figure 3-1 Glenohumeral joint features (Tortora and Derrickson 2014).....	32
Figure 3-2 Skin tear	33
Figure 3-3 Pressure sore.....	34
Figure 4-1 Electrically powered mobile sling hoist (ACC 2012).....	36
Figure 4-2 Electrically powered standing hoist (ACC 2012).....	37
Figure 4-3 Easy Pivot patient handling device (Rand-Scot 2014)	38
Figure 4-4 EZRock patient handling device (Works 2014).....	39
Figure 4-5 Prime engineering lift (Engineering 2014)	39
Figure 4-6 Little Blue lifter	40
Figure 4-7 Multi-bar link patient handling device mechanism	41
Figure 4-8 Rocking chair patient handling device.....	42
Figure 4-9 Comparison of commercial patient handling device mechanisms	44
Figure 4-10 Comparison of University of Canterbury developed patient handling device mechanisms	44
Figure 4-11 Toileting sling (ACC 2012).....	46

Figure 4-12 Toileting sling in use (ACC 2012).....	46
Figure 4-13 Belt support (ACC 2012)	47
Figure 4-14 SureHands Support (SureHands 2014).....	48
Figure 4-15 Easy Pivot chest pad and leg strap (Rand-Scot 2014)	49
Figure 4-16 hoop shaped under arm support.....	50
Figure 4-17 Chest clamp support.....	51
Figure 4-18 Comparison of commercial patient handling device supports	53
Figure 4-19 Comparison of University of Canterbury developed patient handling device supports	53
Figure 5-1 Linked man model diagram.....	56
Figure 5-2 Comparison of the modelled operation force for handle lengths that produce equivalent travel distances to the little blue lifter.....	57
Figure 5-3 Comparison of the modelled potential energy of the patient during the transfer process.....	58
Figure 5-4 Patient transfer showing dragging occurring mid-transfer (left) demonstrated by patient being at same height as starting position (right)	60
Figure 5-5 Physical scale linked man model.....	61
Figure 5-6 Diagram of the patient handling device concept operation from start (left) to finish (right)	62
Figure 5-7 Pivot placement regions	65
Figure 5-8 Comparison of the potential energy during the transfer for the four pivot locations	66
Figure 5-9 Total operation force for pivots located in the four important regions.....	67
Figure 5-10 Tangential operation force component for each region at key points in the transfer process	68

Figure 5-11 Normal operation force component for each region at key points in the transfer process.....	68
Figure 5-12 Optimum operation force	70
Figure 5-13 Novel patient handling device mechanism overview	71
Figure 5-14 Mechanism operation phase 1	73
Figure 5-15 Mechanism operation phase 2	73
Figure 5-16 Mechanism operation phase 3	73
Figure 5-17 Mechanism operation phase 4	73
Figure 6-1 Device configuration used for testing.....	75
Figure 6-2 Force balance platform.....	76
Figure 6-3 Force balance platform schematic	77
Figure 6-4 Barrel distorted reference image.....	80
Figure 6-5 Comparison of the original image (top) and corrected image (bottom)	81
Figure 6-6 Thigh contacting the edge of seat when returning to the chair with a shorter test patient.....	84
Figure 6-7 Variation in operation force between each pivot location for patient 1.....	86
Figure 6-8 Variation in operation force between each pivot location for patient 3.....	86
Figure 6-9 Variation in operation force between repeated transfers	87
Figure 6-10 Comparison of modelling and measured tangential operation force	88
Figure 6-11 Handle usage adopted by some test caregivers	90
Figure 6-12 Plot of operation force after off chair operation is complete	90
Figure 7-1 Close fitting support concept in use.....	99
Figure 7-2 Distributed support concept	100
Figure 8-1 High pressure area (circled)	101
Figure 8-2 Inclined position of support.....	102

Figure 8-3 Support padding configuration for the second test (removed areas shown in red)	103
Figure 8-4 Support padding configuration for third test	105
Figure 8-5 location of main gripping area on the rear side of the support (circled)	106
Figure 8-6 Test patient supported by lower thorax padding	108

List of Tables

Table 1-1	Criteria used to develop the lifting equations.....	6
Table 3-1	Active range of motion of selected joints and motions for people aged over 60	28
Table 3-2	Average pressure pain perception threshold for a select set of areas	29
Table 4-1	Importance of patient handling device mechanism criteria.....	43
Table 4-2	Importance of patient handling device support criteria.....	52
Table 5-1	Anthropometric values and starting angles used for modelling	55
Table 6-1	Primary characteristics of test subjects	74
Table 6-2	Maximum operation force for each test patient and adjustment.....	85

1 Introduction

Many people require assistance to move between positions necessary for everyday living, for example from a chair to a toilet. This process is referred to as a transfer. As will be shown in chapter 1.1 the number of people requiring assistance is significant and as the population ages the need for this assistance will likely increase further.

The forces on a person providing assistance with transfers are far above safe limits, details of this are shown in chapter 1.2. To help reduce the number of injuries many countries have adopted zero manual lift policies such as described in chapter 1.3. Such policies prescribe the use of patient handling devices.

Patient handling devices support the person being transferred and (with mechanisms providing mechanical advantage or external power sources) reduce the force input from the caregiver. The widespread usage of these devices is relatively recent with zero manual lift policies only being adopted widely roughly 20 years ago. As will be shown in the literature review in chapter 2 and overview of the technology in chapter 4 there is great potential to improve upon the design of these devices.

One particular avenue for development which has been identified is a device for the home care environment which is easy enough to use by caregivers who may also be physically impaired. Such a device could decrease the number of individuals which need to be shifted into residential facilities, increasing the comfort of such individuals and reducing the burden on the health care industry.

The work presented in this thesis describes the efforts to devise and evaluate patient handling device concepts which reduce caregiver effort and provide a high level of comfort to a wide range of potential patients. There are a large variety of patient handling tasks, the scope of this thesis covers moving between seated positions. Only mechanical (e.g. not electric) and mobile (e.g. not fixed in place) solutions are considered as these are more applicable to the home care market.

There are two main aspects of patient handling devices which are explored, the mechanism (chapter 5 and 6) which causes the transfer motion and the support (chapter 7 and 8) which holds the patient during the transfer. The correct operation of each of these aspects is dependent on the characteristics of the patient and operator which are covered in chapter 3.

1.1 Patient Care Statistics

The patient handling device developed in this thesis is aimed at the New Zealand market, thus it is important to understand the need for this type of assistive device in this market. A disability survey (Statistics New Zealand 2013) is undertaken generally every five years in New Zealand, the latest of these surveys at the time of writing this thesis is the disability survey 2013. This survey provides a picture of the quantity of disabled, nature of impairment and a number of different measures of their characteristics.

In 2001, a follow up survey: “Living with disability in New Zealand” (M.O.H. 2001), measured the use of hoists and found that an estimated 8000 New Zealanders (0.2%) use or are in need of a hoist. Of these, 1800 are in need of a hoist but do not have access to one, 2000 use a hoist for in-home care and 4200 use a hoist in residential facilities. It may be that the high cost or low suitability of current lifting technology is partly responsible for the 1800 that need but do not have access to hoists. It is also possible that for many, the reason for occupying a residential facility is due to requiring access to a hoist.

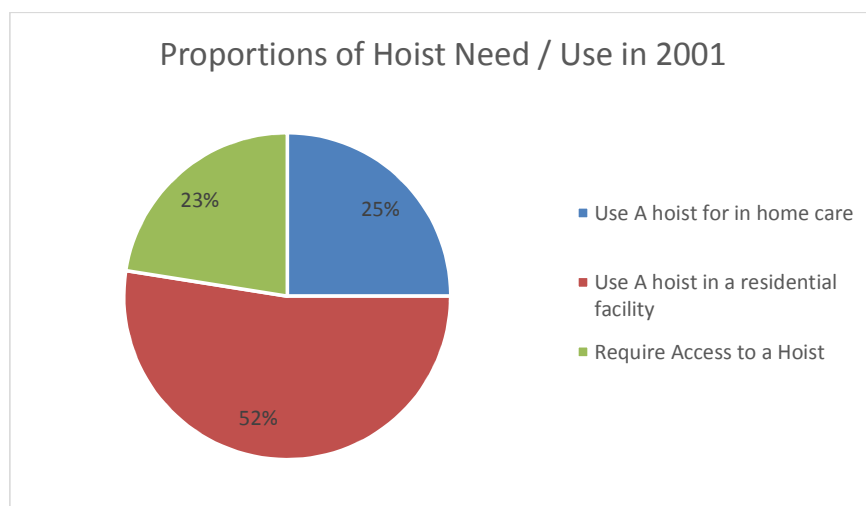

Figure 1-1 Estimated proportions of hoist need type

The impairment type reported by those that required hoists was mobility. 10% of the population reported suffering from mobility impairment. Mobility impairment was far greater in those over the age of 65, affecting 38% of this population group. In 2001 those aged over 65 equated to 11% of the population.

The 2013 survey showed an increase in mobility impairment to 13% of the New Zealand population. A significant component of this increase was the increase in the population over the age of 65 to 14% and the increase in mobility impairment of those aged over 65 to 46%. If the proportion of those with mobility impairment requiring patient handling devices remains the same an estimated 11400 require such devices in 2013. If the trend of an ageing population with higher impairment continues the need for patient handling devices will further increase.

1.2 Caregiver Injuries

Many studies have found that the loads required during manual lifting are greater than a large number of the caregiver population can provide (Bell et al. 1979, Owen 1985, Jensen 1987). This is confirmed by the previously large cost of insurance claims due to patient handling related injuries to caregivers. In 1999 in New Zealand this totalled over \$30 million (ACC 2003).

Many systems have been devised to test if particular handling tasks will have a high risk of causing injury. One such system shown in the United Kingdom's Manual Handling Operations Regulations (Health and Safety Executive 1992) is based on published scientific literature and accumulated practical experience. This system gives weight limits for lifting in various locations (Figure 1-2) and pushing/pulling (20 kg for men, 15 kg for women). Loads within these limits provide a reasonable level of protection to around 95% of working men and women. Manual lifting of patients requires supporting loads of approximately 70kg on average, far greater than these specified limits.

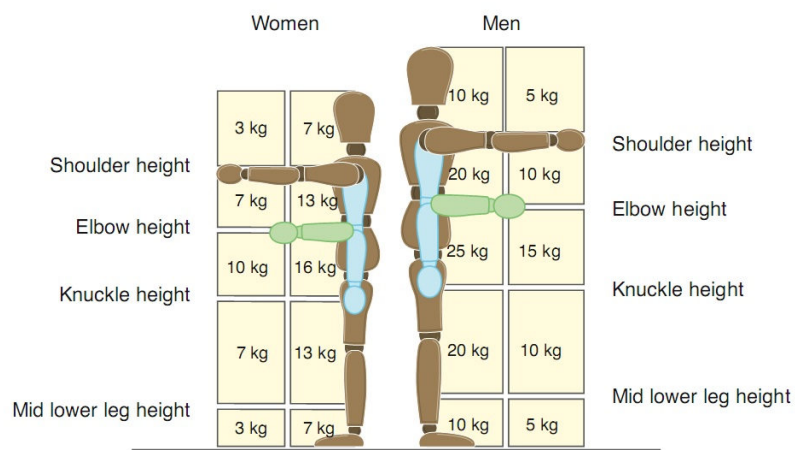

Figure 1-2 Lifting and lowering weight limits

This system of load limits is not applicable to in-home care patient handling devices. Both the direction of the load and the capabilities of the caregiver may differ from those used in determining the limits. Research is needed to define load limits for the operation of in-home care patient handling devices. Based on the above acceptable limits for lifting, a nominal limit of 10kg was used in this thesis to aid in design evaluation.

The criteria used to determine limits are also of interest. An alternative lifting limit system, the “NIOSH Lifting Equation Method” (Waters et al. 1993), uses a formula to output a recommended weight limit for lifting.

Table 1-1 Criteria used to develop the lifting equations

Discipline	Design criterion	Cut-off value
Biomechanical	Maximum disc compression force	3.4 kN
Physiological	Maximum energy expenditure	9.2-19.7 kJ/min
Psychophysical	Maximum acceptable weight	Acceptable to 75% of female and 99% of male workers

Three criteria are used to determine the constants of this formula and are shown in Table 1-1. The biomechanical criterion reflects studies (Chaffin and Park 1973, Anderson et al. 1985) which have shown a relation between L5/S1 compressive force and lower back pain, which constitutes a large proportion of handling injuries. The physiological criterion reflects the possibility of repeated lifting tasks exceeding the lifter’s fatigue limits, resulting in a sudden decrease in strength and possibly injury. The psychophysical criterion is based on research on the perceived maximum load which does not leave the lifter unusually tired. These criteria suggest patient handling devices should be designed to be operated such that little force is transferred through the lower back, low energy is expended and the perception of the load level is low.

1.3 Guidelines

To help ensure caregiving organisations create an environment which is safe for both patients and caregivers many countries have developed patient handling standards. In New Zealand this standard is “Moving and Handling People: The New Zealand Guideline 2012” (ACC 2012). This guideline describes risk assessment and gives details on recommended ways to mitigate the identified risks.

The guideline describes a systematic procedure for identifying and managing hazards to reduce the likelihood of harm to caregivers and patients. A flow chart of the recommended process is shown in Figure 1-3. The flow chart shows four sources of risk, the patient, the carer, the task and the environment. Each of these sources is mitigated by training, use of equipment, moving protocols and incident reporting.

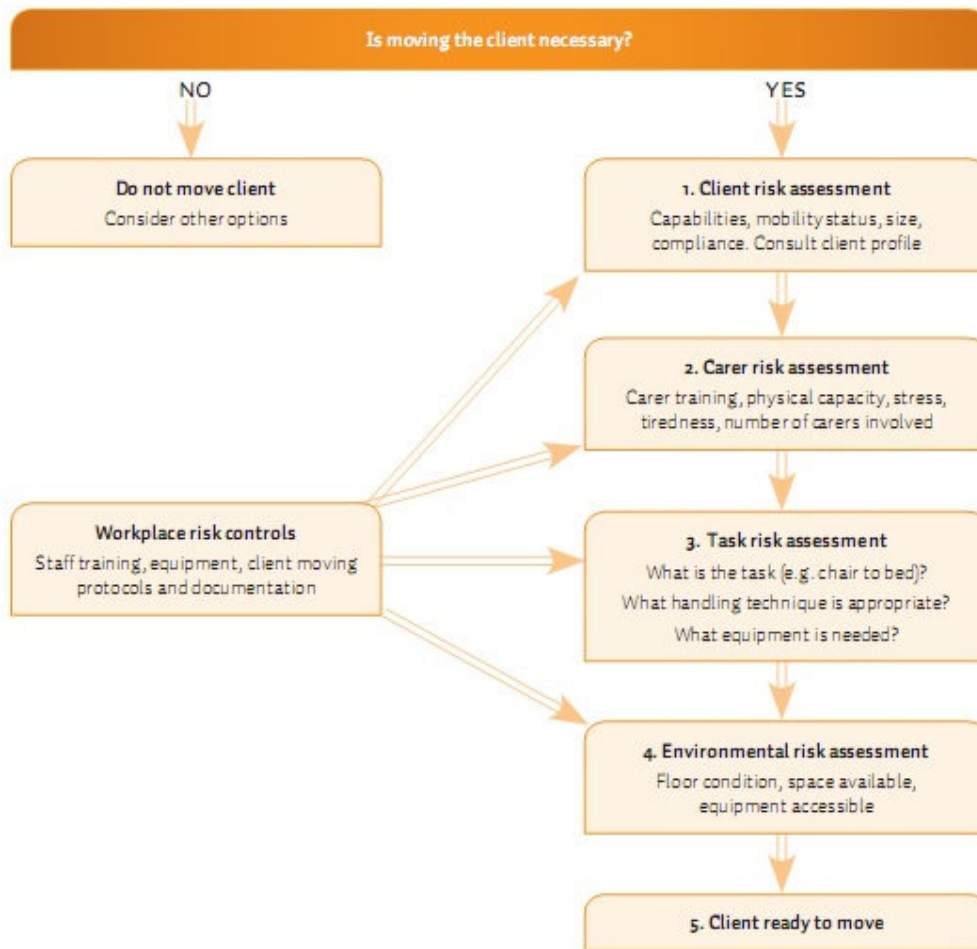

Figure 1-3 Risk management flow chart

An important aspect of risk assessment is the client profile. A client profile lists specific details of the patient that affect moving such as height, weight, skin risk, communication issues and impaired movement. These details are referred to before selecting an appropriate technique or piece of equipment. An example of a client profile is shown in Figure 1-4.

Client profile		
Organisation		
Last review date		Next review date
Ward or unit	Profile completed by	Date
Client details		
Name		Preferred name
Height	Weight	Date of birth
Relevant medical conditions		
Client mobility status		
Independent _____ Supervise _____ Assist _____ Hoist _____		
Note any specific conditions that affect moving the client		
Falling risk	Skin at risk	Medical equipment
In pain	Incontinence	Surgery risks
Impaired movement	Vision problems	Footwear needs
Loss of sensation	Hearing problems	Compliance issues
Other communication issues	Other issues (e.g. cognitive state). Describe here	
Handling plan required? No.... Yes.... complete details below		
Task (add tasks as needed)	Technique to be used, number of carers, equipment needed	Comments*
Sitting and standing		
Walking		
Moving in bed		

Figure 1-4 Example client profile form

A formal risk management process is unlikely to be used for in-home care by non-professionals however it may have an influence on the device being recommended by physiotherapists. The appropriate use of current patient handling devices has been refined by incident reporting over many years of device use. New devices will not have the benefit of this refinement. To be used extensively, it is likely that a significant number of trials in controlled conditions will need to quantify the risks involved with the device.

2 Patient Handling Device literature review

As mentioned in the introduction to this thesis, the accepted solution to the problem of transferring patients is with assistive devices. This solution was reached by a number of studies on the effectiveness of these devices. Potential improvements to patient handling devices have also been studied. This chapter contains a review of four of the most significant of these studies and a summary of the most relevant standard.

2.1 Study 1

A biomechanical and ergonomic evaluation of patient transferring tasks: bed to wheelchair and wheelchair to bed (Garg et al. 1991)

The objective of this study was to evaluate the effectiveness of a variety of patient handling techniques at reducing back stress in nursing personal during bed to chair and chair to bed transfers. At the time of the study a two person under arm lift was commonly used for patient handling. The study compares this commonly used technique to manual pulling (two person gait belt, two person walking belt, one person walking belt, one person Medesign) and hoist assisted (Hoyer lift, Trans-Aid, Ambulift) techniques (Figure 2-1).

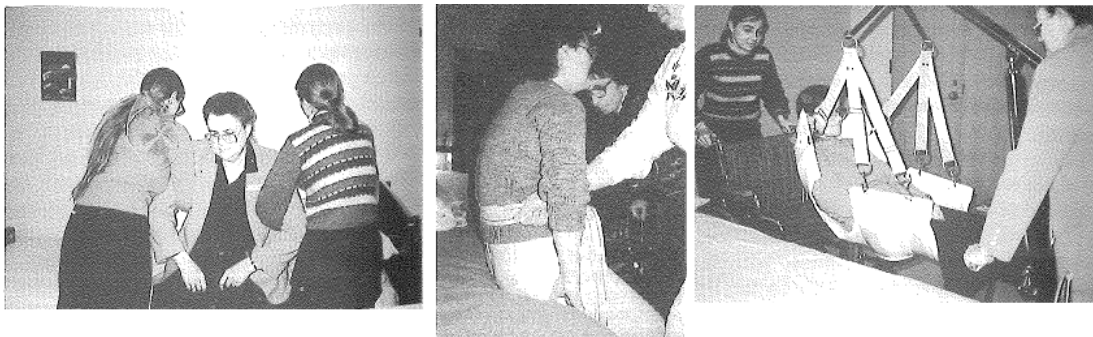

Figure 2-1 Studied patient handling techniques: Under arm lift (left), pulling technique (centre) and hoist assisted lift (right)

2.1.1 Method

Six female nursing students served as both nurses and passive patient models. Each transfer task was performed in a randomised order using a standard procedure. A number of measures were taken after each task, of specific interest to this thesis was:

- The caregiver's perceived stress of performing the transfer task, evaluated by the caregiver's subjective rating on a nine point scale.
- The patient sense of comfort, evaluated by the patient's subjective rating on a seven point Likert scale.
- The time taken to perform the transfer.

2.1.2 Relevant Results & Discussion

Transferring from chair to bed was consistently found by the caregivers to be more difficult with all methods, likely due to the bed being at a greater height than the chair. The relevant results and suggested consequences/explanations for stress rating, comfort and operation time are reported.

Stress rating

Manual shoulder lifting was perceived to be the most stressful technique with a mean whole body rating of 4.9/9. Ambulift hoist was perceived to be the least stressful with a mean whole body rating of 1.2/9. The two person walking belt technique was perceived to be less stressful (mean whole body rating of 3.2/9) than both the Hoyer lift (mean whole body rating of 4.4/9) and Trans-Aid lift (mean whole body rating of 3.8/9).

Although the intent of the hoist is to lower the stress on the caregiver two out of three hoists were more stressful than manual techniques. The study's author suggests the high stress may be due to:

- The additionally required tasks of placing and removing slings from underneath the patient.
- Attaching slings to the hoist
- The location of the handle.

Comfort

The Gait belt had the lowest perceived patient comfort with a mean rating of 5.5/7. Two person walking belt had the highest perceived comfort with a mean rating of 1.9/7, followed closely by the Ambulift with a rating of 2.0/7. The lowest rated hoist, the Hoyer lift, had the second lowest comfort rating with a mean rating of 5.3/7.

As with stress rating two of the three hoists were also found to be less comfortable than manual techniques. The study's author suggests the low patient comfort may be due to the recumbent posture, swaying and dangling chain/hooks.

Time

The manual shoulder lift was the fastest with a mean transfer time of 14.0 seconds. The Trans-Aid hoist was the slowest with a mean transfer time of 198 seconds. The fastest hoist (Ambulift, 130.4 seconds) had an operation time which was over a minute longer than the slowest manual technique (two person walking belt, 63.4 seconds).

The study suggests that a team of two nursing aids would make an average of 38 transfers a day. The addition of approximately one minute to the transfer time (which is achieved by the fastest hoist) would add 40 minutes of additional time spent on transfers daily, which could require the addition of staff or a deterioration of service.

2.2 Study 2

The Design, Biomechanics and Ergonomics of a Novel Patient Lifting Interface (Rolfson 2004)

The objective of this thesis was to resolve safety issues, comfort issues and caregiver manual repositioning associated with sling lifts. This was attempted by adding two additional straps to the sling and by using an adjustable spreader bar with six attachment points (Figure 2-2).

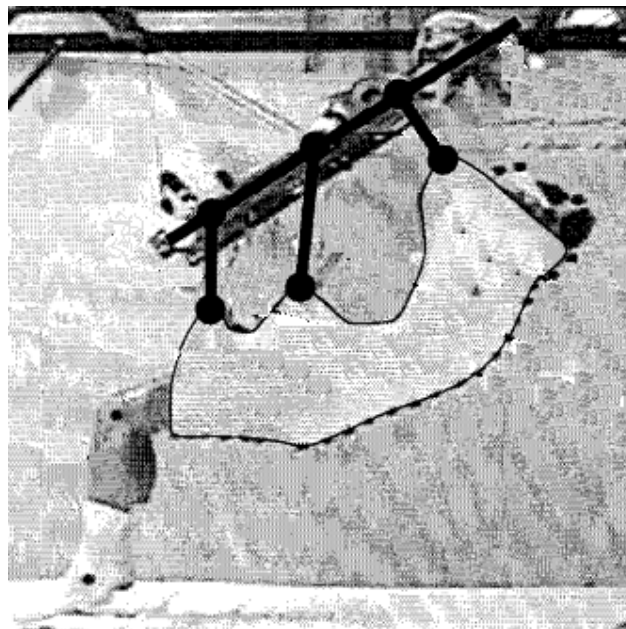

Figure 2-2 Six strap sling with adjustable spreader bar

2.2.1 Method

The sling system was studied with a computer model. Posture measurement was then used to verify posture position as spreader bar configuration, angle and middle strap length was adjusted.

2.2.2 Relevant results

A patient's posture is shown to be able to be controlled between supine and sitting positions with the use of a six strap sling with a rotating spreader bar and variable length middle strap. It is suggested that this system will increase the safety and comfort of bed to chair patient handling for both the patient and caregiver.

2.3 Study 3

Evaluation of a Unique Mechanical Client Lift (Roth et al. 1993)

The objective of this study was to evaluate the effectiveness of a rescue style belt lift (Figure 2-3). The specific tasks evaluated are toileting, changing incontinence pads and bed to chair transfers.



Figure 2-3 Rescue style belt lift

2.3.1 Method

The study was undertaken in a veteran's affairs medical centre on 16 patients. The volunteer patients were selected to have a number of characteristics to increase safety, particularly only weight bearing, contracture free patients were selected. The device was used during routine

duties for at least 1 month by the caregiver staff. A number of measures were taken by use of surveys and independent observations:

- Caregivers perceived physical exertion when using the belt lift and manual lifting procedure, measured using subjective rating by the caregiver on a 5 point scale.
- Caregiver preference of manual versus belt lifting.
- Number of staff required for changing incontinence briefs with each patient handling method.
- Time taken to use the belt lift compared to manual lifts when changing incontinence briefs.

2.3.2 Relevant results

- The belt lift was found to have lower perceived physical exertion for all tasks.
- The belt lift was favoured over the manual lift method for all tested handling tasks. The percentage of caregivers showing a preference for using the belt lift over manual lift was 83% for changing briefs, 69% for toileting and 78% for bed transfers.
- There was a reduction in the number of staff for changing incontinence briefs however the results were not statistically significant, despite it being feasible to change incontinent briefs with one caregiver.
- The time required to change incontinence briefs was found to be less with the belt lift.

2.4 Study 4

An ergonomic evaluation of a patient handling device: the elevate and transfer vehicle (Le Bon and Forrester 1997)

The objective of this study was to evaluate the Elevate and Transfer Vehicle (Figure 2-4) using ergonomic tests. The scope of these tests is for chair to chair transfers.

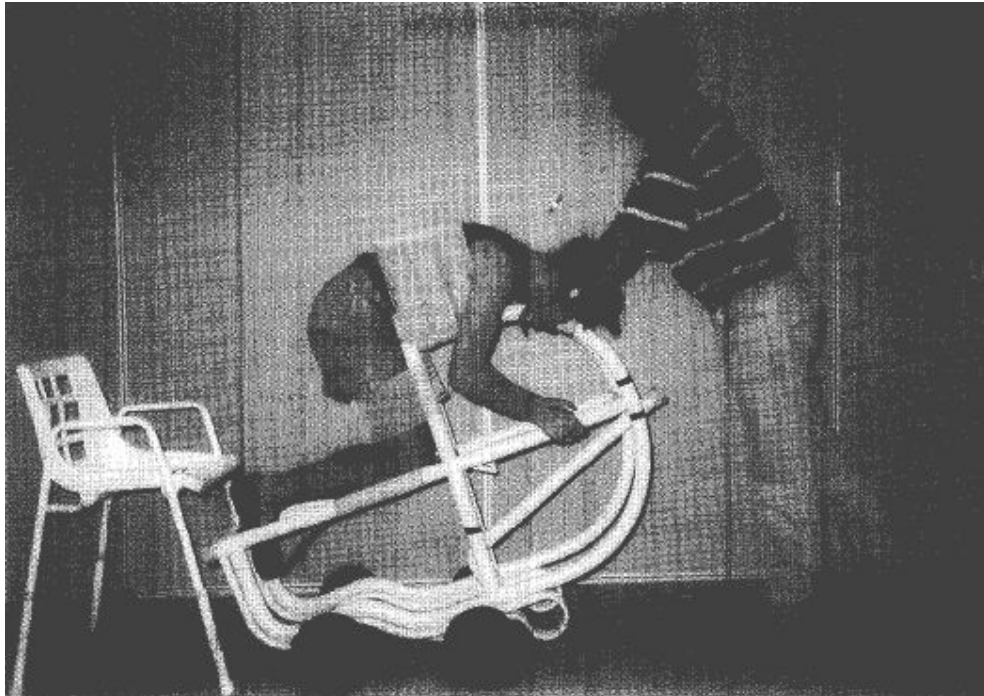

Figure 2-4 Elevate and Transfer Vehicle

2.4.1 Method

Three different test methods were used. The first method was expert appraisals, which were performed with a panel of 11 patient handling experts. The experts operated the device as patients and caregivers. The experts then provided feedback on aspects of safety, human factors and on general issues via a prepared survey and a group discussion.

The Second method was user trials, which were performed using nine male and nine female volunteers representing 5th, 50th and 95th percentile of population data from Pheasant (1986). The volunteers were trained in the use of the device and after which they performed a complete transfer cycle. After the transfer the patient and caregiver evaluations were gathered using a structured interview.

The Final method was performance testing, which was undertaken by following predefined procedures with test weights. The static strength and static stability were measured using procedures outlined in AS 3581-1988. The mechanical advantage of the device was calculated for a 50th percentile male. The manoeuvrability and roll force was measured using procedures outlined in AS 3696-1991.

2.4.2 Relevant results

Expert appraisal

Positive and negative qualitative aspects of the device were identified.

Positive:

- Only one carer needed
- Low effort was required to lift a patient, however room for improvement was identified.
- Greater access for adjusting clothing than existing devices.

Negative:

- Lack of visibility for caregiver when returning the patient to the chair.

- Inability to see patient's face to see signs of distress.
- Uncomfortable jolt in the action.
- Unstable in the elevated position.
- Uncomfortable chest support, particularly for women.
- Velcro straps were difficult to tighten and sounded insecure.
- Low manoeuvrability, due to fixed front wheels and bulky size.
- The transfer position is undignified.

User Trials

The user trials found similar issues as with the expert appraisal. Further emphasised was the need for secure straps. Additionally it was noted that dignity is of less concern than safety and lack of dignity is present in all patient handling.

Performance Testing

A number of issues were also identified during performance testing:

- The average time for a chair to chair transfer was 129 seconds. This time is comparable to some measured sling hoists though the number of required caregivers is less.
- The device was unable to be manoeuvred in the minimum circulation space required by standard AS 1428.1 for toilets.
- The sustained roll force was higher than the weaker 10th percentile of female users for carpet surfaces.

- The device became unstable in the rearward direction at 7.5 degrees which is less than the recommended 10 degrees in AS 3581-1988.
- Creaking sounds from the chest support prevented a safe working load of greater than 80 kg being achieved; AS 3581 – 1988 requires a safe working load of at least 127 kg.

Discussion

Despite the many issues raised, the study's author suggests that the issues are able to be overcome with minor design improvements. It is also suggested that the device would be most suitable for in-home care.

2.5 Standards

To address some of the issues with patient handling devices noted by previous research, standards have been developed. These standards cover requirements and test methods for hoists to ensure they are safe means of supportive lifting and moving. The most relevant of these is ISO 10535:2006 (ISO 2006) which is summarised in the following chapter.

Scope

The standard applies to sling hoists (both mobile and fixed), hoists with solid seats, standing hoists and body support units for these devices. The standard does not specifically apply to forward pivoting devices, perhaps due to their smaller market share.

Covered in the standard are ergonomics and safety. Specifications and test methods are given for each of these categories. Although the standard may not apply to devices developed in this thesis, aspects in the standard which may act as guidelines are shown below with the corresponding clause shown in parenthesis following the specification.

Ergonomics

General

- Distance between handle and part of the device shall be not less than 35mm. (4.1.2)
- Distance above a foot pedal shall be not less than 75mm. (4.1.2)
- Diameter of handles shall be between 19 mm and 43 mm. (4.1.2)
- Foot pedals shall not be over 300 mm above the floor. (4.1.2)
- Hand controls shall be at a height of 800 mm to 1200 mm. (4.1.2)
- The minimum height of handles for pushing or pulling shall be 900 mm. (4.1.2)

Operation force

- The operating force when operated by hand shall not exceed 105 N (4.9.1)
- The operation force when operated by foot shall not exceed 300 N (4.9.1)

Moving force

- The starting moving force when tested, fully loaded, on a smooth horizontal steel plate shall be not more than 160 N. (5.5.1 / 6.5.1)
- The driving moving force when tested, fully loaded, on a smooth horizontal steel plate shall be not more than 85 N. (5.5.1 / 6.5.1)

Safety

General

- All load bearing fasteners shall be locked to prevent inadvertent detachment.
(4.3.1.4)
- All accessible features shall be smooth and have no burrs or sharp edges. (4.3.1.8)
- It shall not be possible to assemble the hoist in a manner which affects the safety.
(4.3.1.9)
- Protection against shearing crushing trapping and abrading shall be in accordance with IEC 60601-1. (4.3.1.10)
- The hoist shall ensure that the patient does not fall in the event of a single fault of the machinery. (4.3.1.19)

Stability

- When both loaded to the maximum capacity and unloaded the hoist shall not lose its equilibrium with the device angled:
 - 10 degrees forwards and backwards in the intended travel direction.
 - 7 degrees forwards and backwards in the most adverse travel direction.
 - 5 degrees in any other direction. (5.3.1 / 6.3.1)

Strength

- The hoist shall be capable of lifting a person of 120kg mass. (4.3.1.1)
- The hoist shall withstand 1.5 x the maximum load for 20 minutes without deformation or wear. (5.2.2/6.2.2)

Immobilisation

- An immobilisation device must be fitted which shall prevent travel of greater than 10 mm when the hoist is placed on a 1 degree slope in the most adverse position for 1 minute. (5.4 / 6.4)

Durability

- The hoist and support shall show no signs of deformation or wear after a fully load test cycle of 11000 transfer cycles. (4.10.2)

3 Patient Characteristics

The standard in chapter 2.5 above emphasizes ergonomic design; a core aspect of this is human centred design. In order to design a patient handling device in a human centred way typical characteristics of the patient are necessary. A brief overview of the typical cause of disability for the patient, range of motion of the patient, how the patient experiences pain and the injuries they may be susceptible to is discussed in this chapter.

3.1 Common Causes of Disability

Interviews with patient handling experts (Appendix A) revealed that people becoming deconditioned is the most significant reason for patients to require assistance with transfers. Deconditioned is defined as having lost fitness or muscle tone, especially through lack of exercise (Oxford Dictionary of English 2010). This condition decreases the maximal strength of the person's muscles, which can affect the person's ability to stand, walk, balance, maintain a posture or lift objects.

The elderly are particularly susceptible to this condition as muscle strength tends to decrease with age (Tortora and Derrickson 2014). Additionally conditions such as arthritis may make physical activity painful, decreasing the likelihood of those affected from performing regular physical activity. The severity of this condition varies greatly among those affected who require assistance with transfers. Some may have enough strength to walk but lack strength to stand from a seated position while others may have little ability to move their own limbs. Upper body and lower body strength may also vary depending on the cause of the deconditioning.

Table 3-1 Active range of motion of selected joints and motions for people aged over 60

		Male		Female		Source
		5th percentile	95th percentile	5th percentile	95th percentile	
Knee	Flexion	114.6	147.4	112.9	149.1	Roach and Miles (1991)
	Extension	0.0	0.0	0.0	0.0	Roach and Miles (1991)
Hip	Flexion	101.6	134.4	101.6	134.4	Roach and Miles (1991)
	Extension	5.5	28.5	6.1	25.9	Roach and Miles (1991)
Lumbar Spine	Flexion	39.9	61.7	38.8	65.8	Van Herp et al. (2000)
	Extension	6.5	23.7	7.7	26.1	Van Herp et al. (2000)

Chapter 1.1 revealed that a significant proportion of those requiring patient handling devices are over 65. Data is available for this particularly relevant group; a summary of this is shown in Table 3-1. The standardised methods for collecting range of motion data are available.

3.3 Pain

It is important that the transfer process is pain-free to ensure the patient will not avoid transfers. Transfer devices have the potential to inflict mechanical pain on the patient. Mechanical pain is a category of nociceptive pain where peripheral nerve fibres are stimulated by pressures which approach levels which would cause damage (Woolf 2010).

The sensitivity to mechanical pain may be quantified by measuring the pain perception threshold. Pain perception threshold is the lowest level of stimulation which causes the pain for the patient (IASP 2014). Mechanical pain perception threshold is commonly measured using a pressure threshold meter. This meter consists of a force gauge (with 11kg range) attached to a 1cm² rubber disk. The load is steadily increased until pain or discomfort is felt by the test subject.

Table 3-2 Average pressure pain perception threshold for a select set of areas

Location	Pressure threshold (kPa)	
	Male	Female
Pectoralis major muscle	520	402
Temporal region	258	130
Palm of hand	743	442

Table 3-2 shows some average values of pressure pain threshold measured using such a device on a number of different areas from two studies (Fransson-Hall and Kilbom 1993, Kinser et al. 2009). The values show that pain perception varies between locations of pressure application. Pressure pain threshold is also affected by the rate at which pressure is increased, with threshold lowering the slower the pressure increase. The above readings were at a rate of approximately $25 \text{ kPa}\cdot\text{s}^{-1}$. Transfer devices apply pressure for a more sustained period thus these values are not entirely suitable as pressure limits, but are indicative of relative sensitivity. Pain would be experienced at lower pressure levels than in Table 3-2.

Advancing age may cause either an increase or decrease to the sensitivity of mechanical pain (Yeziarski 2012). The sensitivity of the sensory system decreases with advanced age however the presence of inflammation is more likely (due to arthritis for example) which may lead to inflammatory pain. Inflammatory pain is caused by hypersensitivity to stimulus in the region surrounding an area of tissue damage. This hypersensitivity causes stimulation which may not have previously caused pain to be painful. An example of this is the increase in sensitivity experienced around a wound. This pain acts to prevent further damage to areas that have already been weakened (Basbaum and Woolf 1999).

3.4 Injury

Preventing injuries to patients during patient handling is vital. Ensuring there is no pain will ensure safety in many cases, however in certain patient handling situations it may be possible for injury to occur before a pain sensation is felt or the patient may be unable to communicate the sensation of pain. Three of the most significant types of injuries which may occur are dislocations, skin tears and pressure sores.

Dislocation

A dislocation is the displacement of a bone from its joint or socket (Melloni 1998). Some of the originally used unsafe manual transfer processes were thought to have the potential to cause dislocations. An example of this is the Drag lift which in unofficial studies is suggested to be a major cause of shoulder dislocations in the elderly (Lloyd 1997).

The main joint which provides the motion in the shoulder is the glenohumeral joint (Figure 3-1). This joint is the most frequently dislocated joint in the human body (Martini et al. 2009). To allow the large freedom of movement the articular capsule is loose and the contact between the ball of the humeral head and socket of the glenoid cavity is shallow, which makes the joint unstable. To compensate for these weak features muscles surrounding the shoulder joint, particularly the rotator cuff muscles (supraspinatus, infraspinatus, teres minor, and subscapularis), provide added stability. These muscles work as a group to hold the head of the humerus in the glenoid cavity (Tortora and Derrickson 2014). Ageing causes a decrease in muscle mass and maximal strength of the muscle thus dislocation will be more likely.

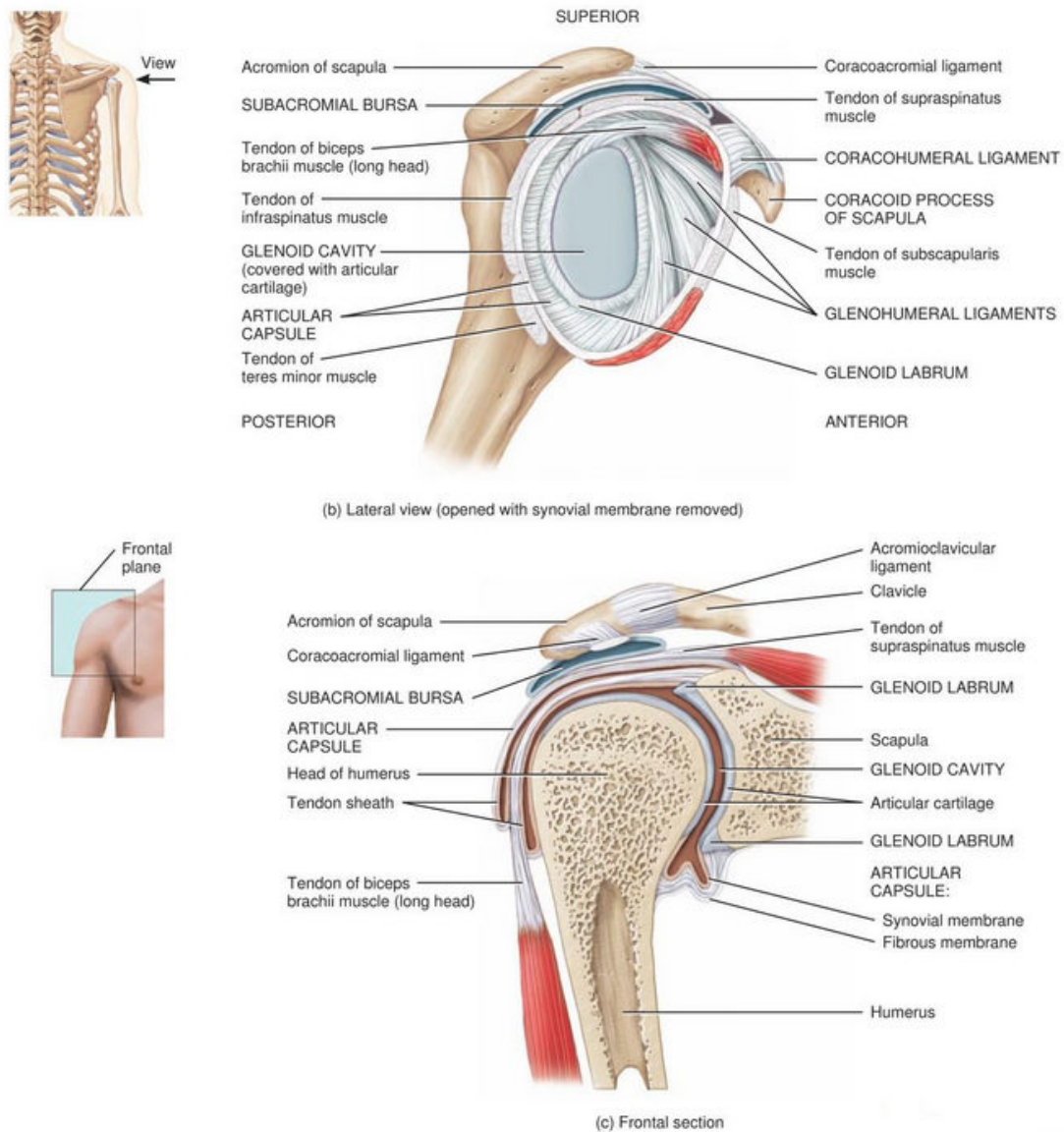

Figure 3-1 Glenohumeral joint features (Tortora and Derrickson 2014)

In a dislocated shoulder the head of the humerus most often displaces below the glenoid cavity (Martini et al. 2009). The articular capsule is least protected in this lower area, thus loads applied in this direction should be avoided.

Skin Tears

A skin tear (Figure 3-2) is defined as a traumatic wound resulting from the separation of the epidermis from the dermis caused by friction, shearing forces and/or blunt trauma. Transfers are a significant cause of skin tears, with 18% of reported skin tears where the cause is known being attributed to them (Leblanc and Baranoski 2009). This is likely due to friction from straps and hard object which the patient may bump into.



Figure 3-2 Skin tear

Skin tears are a particular problem for the elderly. The skin of the elderly goes through many changes which contribute to the increased risk of skin tearing. Elastic fibres lose some of their elasticity, decreasing the skin's resilience. Sweat production lowers which causes skin to become dry and flaky. The skin's immune responsiveness decreases, which increases the risk of infection and skin damage. Also the overall thickness of the skin decreases (Benbow 2009).

Pressure Sores

A pressure sore (Figure 3-3) is a wound formed by necrosis of the skin due to sustained pressure combined with numerous other factors (Bass and Phillips 2007). The formation of pressure sores is a function of pressure and time and is also affected by other factors such as moisture, circulation, denervation, infection, spasticity and nutrition.



Figure 3-3 Pressure sore

The formation of pressure sores while on transfer devices is very unlikely due to the generally low pressures required and short timeframe of most transfers; however it may be possible for the transfer process to cause an initial wound which then may accelerate the formation of a pressure sore if the wound is then placed under sustained pressure in another circumstance. The Guide to the Handling of Patients (Lloyd 1997) suggests that the contribution of the former to pressure sores may have taken place with the unsafe lifting practice, the drag lift. Avoiding contact with areas that may later be placed under sustained pressure may be beneficial.

4 Patient handling device review

A variety of mechanisms and supports have been developed by entrepreneurs and during research at the University of Canterbury to aid patient handling. Each of these mechanisms and supports operate in unique ways which result in different strengths and weaknesses. This chapter describes the most significant of these and compares their relative strengths; allowing potential development avenues to be identified.

4.1 Mechanism

The mechanism is the part of the patient handling device which assists the motion of the patient out of the chair. The following section contains reviews of the important existing mechanical patient handling device mechanisms. The operation of each mechanism and their main strength and weakness is described individually. The relative suitability for each device for in-home care is reviewed at the end of the section.

4.1.1 Mobile Sling Hoist

The mobile sling hoist mechanism is based on the design of a jib crane. The patient is supported by a sling which is attached to hooks on a spreader bar at the end of a boom positioned above the patient. The boom is connected at the opposite end to a mast with a pin joint and is raised or lowered (lifting or lowering the patient) with a hydraulic ram. The mast is fixed to a caster wheeled base which extends from the mast to beyond the rear of the patient. The base is generally adjustable and low profile to fit around or under furniture. The caregiver actuates the device by turning a crank or operating a pump. Manual units have largely been replaced with electrical units (Figure 4-1).



Figure 4-1 Electrically powered mobile sling hoist (ACC 2012)

The main strength of this mechanism is its versatility; it can accommodate most patients (children and bariatric patients) and handling tasks (lifting from bed and from the floor). The main weakness of this mechanism is the requirement of two caregivers when in manual form, one to support the patient and one to operate the pump.

4.1.2 Standing Hoist

A standing hoist mechanism functions in a similar fashion to the sling mechanism. The main difference is instead of lifting the whole patient in a sling only the upper body is lifted. The patient's lower legs are supported on a platform and a knee pad while the patient's upper body is supported by belt around the thorax. The location of the connection point to the belt is in front of and slightly above the patients shoulders and needs to move forwards and upwards (relative to the patient) during the lifting process. Many sling hoists are designed such that, with the addition of lower leg supports and adjustment of the boom, they may be converted into a standing hoist. As with the sling hoist, the caregiver actuates the device by turning a crank or operating a pump. Again manually units have been largely replaced by electrical units (Figure 4-2).



Figure 4-2 Electrically powered standing hoist (ACC 2012)

The main strength of this mechanism is the upright final posture that is assumed. The main weakness of this mechanism is the unnatural motion involved.

4.1.3 Easy Pivot

The Easy Pivot mechanism is based on the manual standing pivot transfer. As with standing hoist, the lower legs are constrained and only the upper body is lifted. Instead of a belt around the torso a strap is placed under the legs and behind the back; the torso rests on a semi-rigid chest pad. The patient's upper body is rotated forwards off the chair, pivoting about their knees to finish with their upper body supported by the chest pad. The caregiver operates the device by handles which extend out from the chest pad. Figure 4-3 shows a typical example of an Easy Pivot device.



Figure 4-3 Easy Pivot patient handling device (Rand-Scot 2014)

The main strength of this mechanism is the speed of operation. The main weakness is the high range of motion required of the patient.

4.1.4 Whole Body Pivot

A whole body pivot device is a device where the whole body of the patient is tilted forward out of a seated position. Two prominent examples of this are the EZRock (Figure 4-4) and the Prime Engineering Lift (Figure 4-5). Like the Easy Pivot the patient is supported about their lower legs, underneath their thighs and about their torso. The devices tilt forward about the end of the patient's feet. The caregiver tilts the device by resting a foot on a rest at the bottom of the device and pulling back on a handle located near the chest pad.



Figure 4-4 EZRock patient handling device (Medica-Works 2014)



Figure 4-5 Prime engineering lift (Prime-Engineering 2014)

The main strength of these mechanisms is the mechanical simplicity due to no moving parts being required during the transfer. The main weakness of these mechanisms is the motion does not provide much clearance from the seat.

4.1.5 Little Blue

The little blue (Figure 4-6) is similar to the easy pivot patient handling device. The little blue attempts to reduce the effort required to operate the device by decreasing the change in potential energy of the patient during the lifting process. The little blue consists of an under arm support which is connected to a pivot located below the patient's thigh and approximately on third of the distance from the knee to the hip. Like the easy pivot, the feet are also supported on a platform and the knees are constrained. The pivot is located such that the centre of mass of the patient is the same height in the final transfer position as in the start position. A consequence of this pivot location is that the torso is required to rotate through a greater angle than the support thus a specialised under arm support must be used to accommodate this.



Figure 4-6 Little Blue lifter

The main advantage of this mechanism is the low change in potential energy of the patient during operation. The main weakness of this mechanism is the required pivot placement which interferes with a number of typical seats.

4.1.6 Multi-Bar Linkage

The multi-bar linkage prototype (Figure 4-7) is a development of the little blue lifter. As with the little blue the lower legs are supported by a foot platform and knee support. A chest clamp support is used to support the upper body. The angle and position of the chest clamp support is controlled by a multi-bar linkage. The use of a multi bar linkage allows the motion of the patient to be controlled to produce a motion similar to the little blue without the patient rotating about the support. Additionally the mechanism is positioned in front of the patient so that it does not interfere with the seat. The device is operated by a handle attached to one of the links.



Figure 4-7 Multi-bar link patient handling device mechanism

The main strength of this mechanism is the ability to provide a low energy transfer without being restricted by furniture. The main weakness is the high mechanical complexity from multiple linkages and pivots.

4.1.7 Rocking Chair

The rocking chair prototype (Figure 4-8) is a development similar to the EZRock and prime engineering patient handling devices. The device consists of an under arm support, foot platform and knee support as with the little blue, however these are fixed to two curved rails which rest on the floor. The centre of the curve is located about the centre of mass of the patient. To operate the device is rolled forward on the floor onto a set of wheels which allow the patient to be moved to a new location. With the centre of the curved rails being located at the centre of mass very little work is required to perform a transfer.



Figure 4-8 Rocking chair patient handling device

The main strength of this device is the ability to provide a low change in potential energy of the patient during a transfer while having no moving parts. The main weakness of this mechanism is the restricted seating furniture it may be used with due to the required rocker placement.

4.1.8 Mechanism Comparison

Each of the previously described mechanisms have varying strengths and weaknesses. These may be categorised into six criteria speed, ease of use, versatility, portability stability and simplicity.

Table 4-1 Importance of patient handling device mechanism criteria

Criterion	A high attribute level is needed to...	Weighting
Speed	prevent unsafe, faster manual processes from being used	5
Ease of use	ensure operators will be able/ willing to use the device	5
Versatility	increase the range of situations and people which the device may be used with	2
Portability	increase the a number of places the device may be used	3
Stability	prevent tipping and provide a sense of security	2
Simplicity	reduce cost and increase reliability	1

Not all criteria are equally important for an in-home care device. Table 4-1 shows values rating the importance of each criterion and gives a description of the importance of each criterion.

Each mechanism, in its best possible embodiment, was rated from zero to five in each of these criteria this was then multiplied by the importance rating. Figure 4-9 and Figure 4-10 show comparison of the ratings for the reviewed commercial and University of Canterbury developed patient handling device mechanisms respectively. These figures reveal that the little blue lifter and rocking chair lifter have the most promise for in home care.

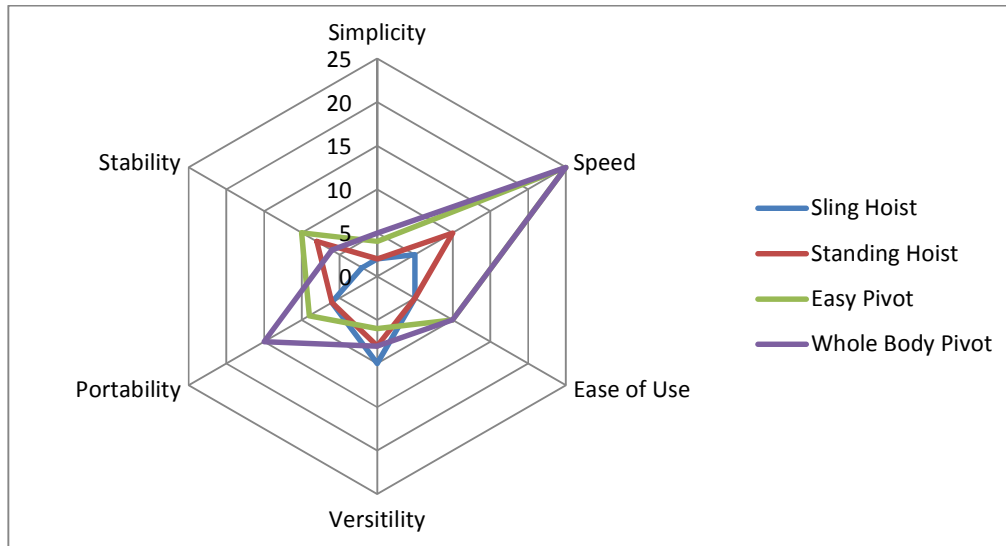

Figure 4-9 Comparison of commercial patient handling device mechanisms

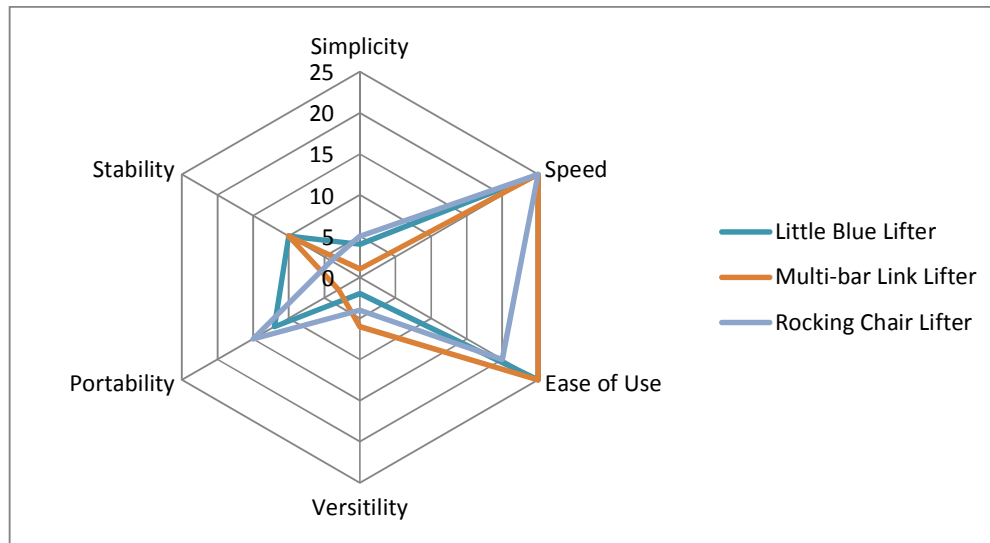

Figure 4-10 Comparison of University of Canterbury developed patient handling device mechanisms

4.2 Support

A support is the part of the patient handling device which acts as an interface between the device and patient. The following section contains reviews of the important existing mechanical patient handling device supports. The operation of each of the supports and their main strength and weakness is described individually. The relative suitability for each support for in-home care is reviewed at the end of the section.

4.2.1 Sling

A sling support comes in many forms. The most commonly used is the toileting sling. This sling consists of a flat U-shaped piece of material with four fabric hoist attachment points (Figure 4-11). To fix the support in place from a seated position the patient is first leaned forward and the base of the U is placed behind the patient's back. The patient's legs are lifted and the legs of the U are placed under each leg. Hooks on the base of the U are threaded under the arms and attached to a spreader bar on a mobile sling hoist. Hooks at the end of the legs of the U are also attached to the spreader bar; these are often crossed over to bring the legs together during lifting. During lifting the patient hangs in a supine posture (Figure 4-12), the caregiver is required to provide additional support to transition from the seated position to the supine position. Patients of different sizes are accommodated by multiple integrated fabric hoist attachment points.



Figure 4-11 Toileting sling (ACC 2012)



Figure 4-12 Toileting sling in use (ACC 2012)

The main strength of this support is its versatility; it may be used from lying postures as well as seated. The main weakness of this support is the difficulty involved with applying the support to the patient.

4.2.2 Belt Support

The belt support is based on rescue lift supports (Roth et al. 1993). The support consists of a lightly padded strip of material (Figure 4-13). The support is wrapped around the lower thorax of the patient and attached to a standing hoist. The patient's upper body weight is supported by friction. A consequence of the way which the support grips the patient is that the patient must lean backwards during the lifting process.



Figure 4-13 Belt support (ACC 2012)

The main strength of this support is the ease by which it may be applied to the patient. The main weakness of this support is the need for moderate upper body strength to prevent the support slipping under the arms.

4.2.3 SureHands Support

The SureHands support (Figure 4-14), like the belt support uses friction to lift the patient however in this case the grip force is provided by a mechanical linkage. This support is designed to be used with a mobile sling hoist and consists of two pivoting pads which are placed half way up the sides of the patient's thorax and two padded hooks for supporting the patient's legs. The pads are connected to a scissor mechanism which is arranged such that as lifting load is applied the pads are forced together to provide a gripping force.



Figure 4-14 SureHands Support (SureHands 2014)

The main advantage of this support the ease by which it may be applied, it can be applied by the patient in some circumstances. The main weakness of this support is the mechanical complexity and bulk of the associated mechanism.

4.2.4 Chest Pad

A chest pad is a padded semi-rigid support used for forward tilting patient handling devices such as the easy pivot (Figure 4-15), the prime engineering lifter and the EZRock. The chest pad progressively supports more of the load of the upper body as the patient is tilted forward. A support under the legs is used to provide the initial lifting support. The under leg support can either be a rigid pad or a strap. The insertion of the under leg support is aided by the patients legs being raised on a platform. A strap behind the back is also commonly used to add additional security.

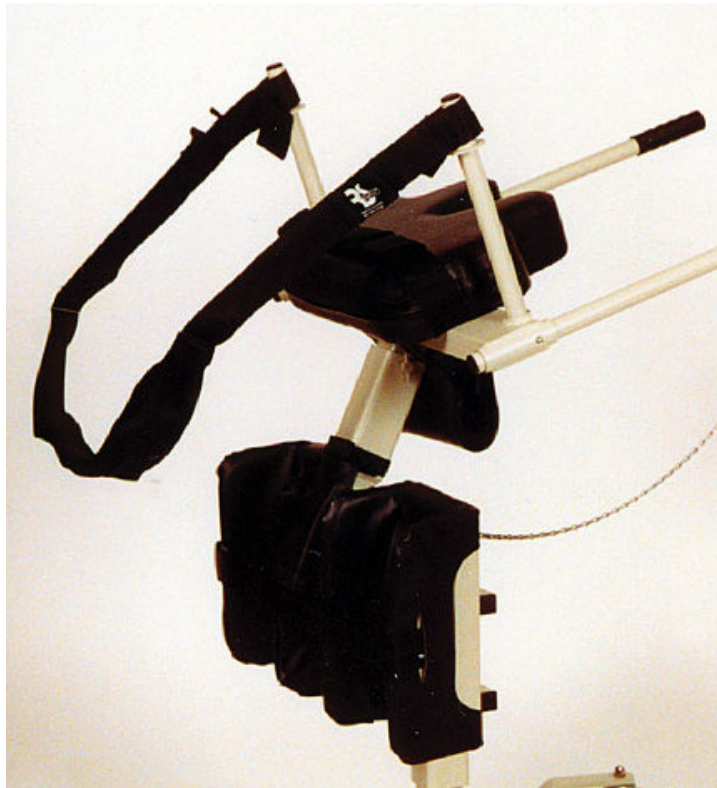

Figure 4-15 Easy Pivot chest pad and leg strap (Rand-Scot 2014)

The main strength of this support is its high security due to its solid nature. The main weakness of this support is the difficulty involved with applying the straps.

4.2.5 Under Arm

The under arm support (Figure 4-16) consists of a padded bar or hoop which rests under the patient's upper arms and on their upper chest. To enter the support the patient is required to lift their arms over the support and hold onto a grip. During the transfer the patient is required to support their upper body weight by pushing down on this support with their upper arms while holding a grip. The support allows the patient to rotate their torso relative to the support as needed by the little blue lifter.



Figure 4-16 hoop shaped under arm support

The main advantage of the under arm support is the high speed at which it may be applied. The main disadvantage is the high physical strength required from the patient during transfer.

4.2.6 Chest Clamp

The chest clamp (Figure 4-17) is based on the chest pad and belt support supports. The support consists of a chest pad which supports the front of the patient's thorax and a strap around the back of the patient. Like the belt support the patient is supported by friction. The gripping force is supplied by the caregiver tightening the strap by mechanical means. The support does not allow any rotation of the thorax.



Figure 4-17 Chest clamp support

The main advantage of this support is the high level of security without the need for straps under the legs. The main disadvantage is the time which is required to apply and tighten the strap.

4.2.7 Support Comparison

Each of the previously described supports have varying strengths and weaknesses. These may be categorised into six criteria speed, ease of use, versatility, safety, comfort and simplicity.

Table 4-2 Importance of patient handling device support criteria

Criterion	A high attribute level is needed to...	Weighting
Speed	Prevent unsafe, faster manual processes from being used	5
Ease of use	ensure operators will be able/ willing to use the device	5
Versatility	increase the range of situations and people which the device may be used with	1
Safety	prevent injuries such as skin tears and dislocations	2
Comfort	Ensure patients will not resist use of the device	5
Simplicity	reduce cost and increase reliability	1

Not all criteria are equally important for an in-home care device. Table 4-2 shows values rating the importance of each criterion and gives a description of the importance of each criterion.

Each support, in its best possible embodiment, was rated from one to five in each of these criteria this was then multiplied by the importance rating. Figure 4-18 and Figure 4-19 show comparison of the ratings for the reviewed commercial and University of Canterbury developed patient handling device supports respectively. These figures reveal that the belt support, sure hands support and chest pad have the most promise for in home care.

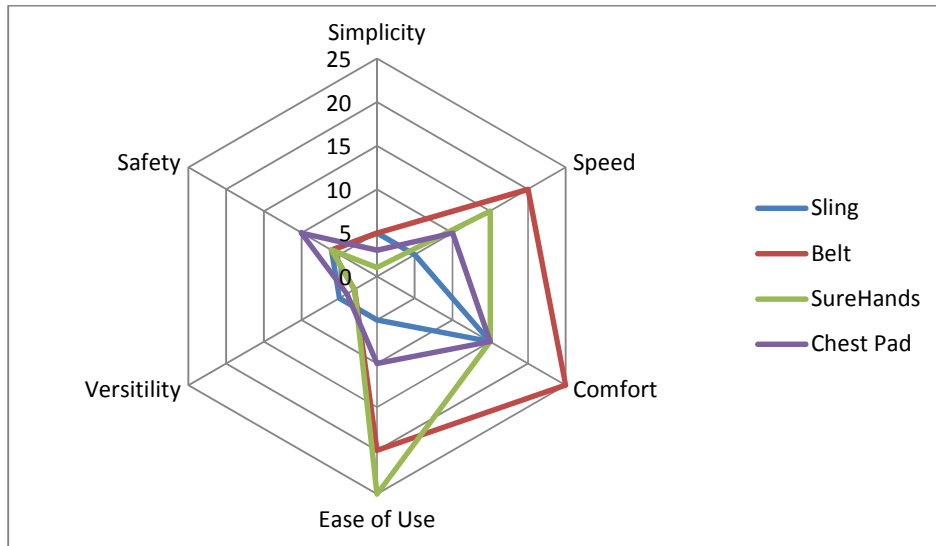

Figure 4-18 Comparison of commercial patient handling device supports

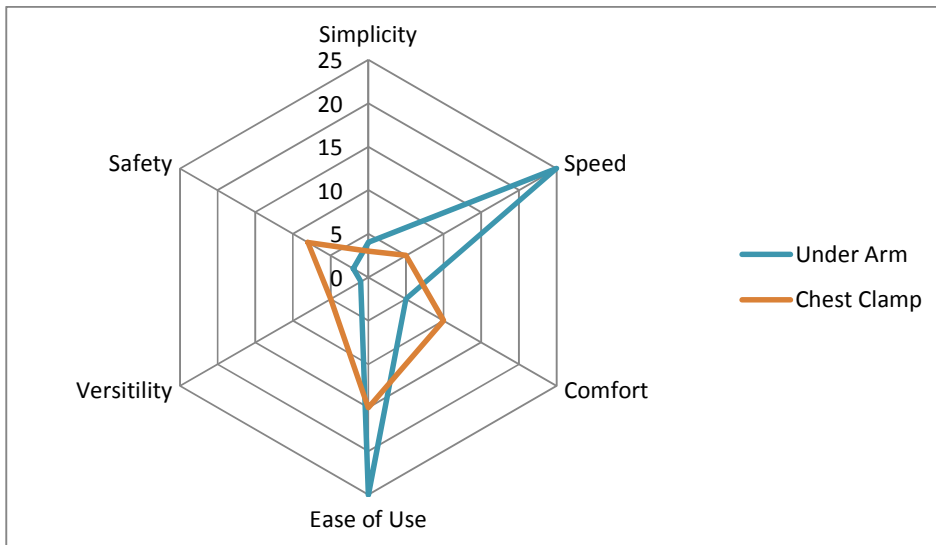

Figure 4-19 Comparison of University of Canterbury developed patient handling device supports

5 Mechanism Development

The studies of patient handling device performance in chapter 2 identified that some existing patient handling devices take a long time to operate and that they can be perceived to take as much effort to use as manual lifting. The high effort involved with existing devices is particularly troublesome for in-home care due to the likely caregivers likely being elderly (chapter 1.1) with reduced physical ability (chapter 3). These factors may compound to make in-home care with current patient handling devices to be an impossible task for many.

The review of mechanisms in chapter 4.1 revealed ways which patient handling devices may be developed to overcome these problems. This chapter describes the process used to develop a mechanism which aims to address the identified issues. Specifically covered is:

- Modelling existing mechanisms which are close to meeting the need
- Detailed review of the aspects of these mechanisms which are advantageous / detrimental to meeting the need
- Generation of new concept mechanisms
- Modelling of the concept mechanisms
- A review of the selected design

5.1 Modelling of Existing Devices

Existing manual patient handling devices the Easy Pivot, Prime Engineering Lifter and the Little Blue Lifter were modelled using a three segment linked man model as described by Pheasant (1986). The 3 segments represent the shins, thighs and the torso. The following assumptions were made:

- The body segments remain rigid.
- The joints act as simple hinges.
- Friction is negligible.
- The caregiver will operate the device in the most efficient manner.

Table 5-1 Anthropometric values and starting angles used for modelling

Segment	Segment Length (m)	Segment Mass (kg)	Centre of Mass Position	Angles - Clockwise positive
Upper Arms	0.305	4.172	52% from elbow	90° from trunk
Forearms	0.270	3.427	52% from wrist	90° from trunk
Head	0.255	4.619	50% from top of neck	0° from trunk
Neck	0.080	1.639	50% from shoulder	5° from trunk
Trunk	0.500	37.250	53% from hip	-8.75° from vertical at hip
Thighs	0.425	14.900	59% from knee	-84.7° from vertical at knee
Shins	0.410	6.407	56% from ankle	-5° from vertical at ankle
Feet	0.210	2.086	50% from ball of foot	111° from vertical at ankle
Total	1.745	74.5		

Table 5-1 shows the assumed values for segment lengths, starting positions and mass properties. These values were for a 50th percentile man (gathered from Pheasant (1986)). The arms were assumed to be outstretched perpendicular to the torso as this was most advantageous for all devices. A plot of the represented model is shown in Figure 5-1.

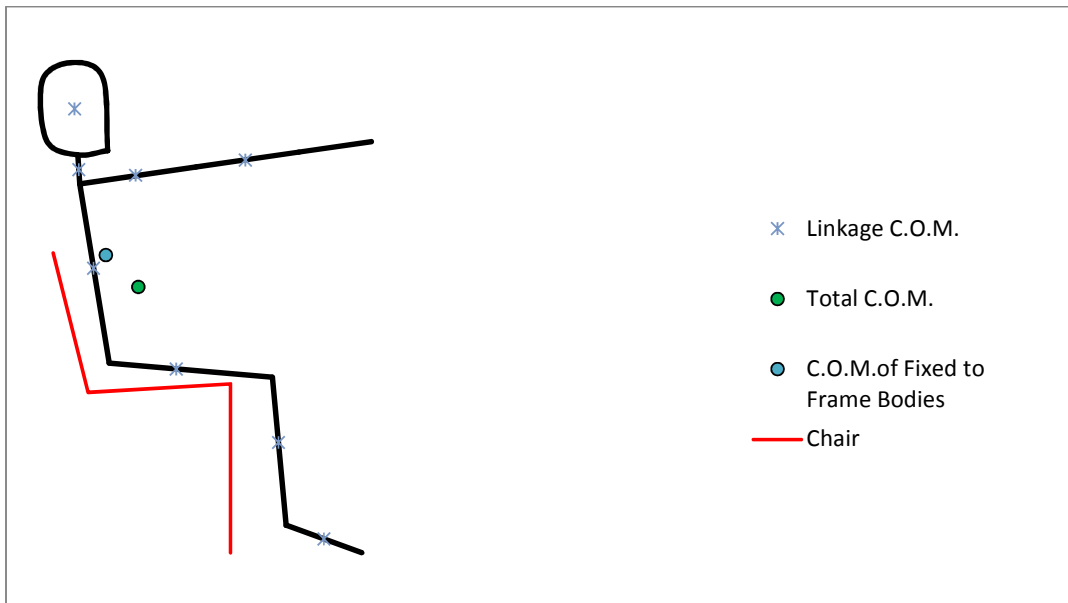

Figure 5-1 Linked man model diagram

The two points shown in Figure 5-1 are of particular interest. The circular point to the lower right represents the total centre of mass of the patient. The locus of this point can be used to determine the work required for the prime engineering lifter, where the whole body is moved. The circular point to the upper left represents the centre of mass of the upper body, including the component of thigh weight which is supported by the hip. The locus of this point can be used to determine the work required for the easy pivot and little blue lifter due to the knee being constrained, leaving the lower legs and feet to remain stationary for those devices.

To calculate the operation force each segment was analysed separately in an assumed state of static equilibrium, resulting in three unique equations for each link. These equations were then solved simultaneously to determine the external forces on the entire system, including the operation force.

Each device has differing handle positions which affect the operation force. A device with a handle further away from the patient would have reduced operation force but the distance the handle would need to be moved through would be greater. A differing handle travel could affect the operator's perception of the force (a factor noted in chapter 1.2). To normalise this effect the operation force for the devices was modelled using handle positions which have equivalent handle travel distances. Figure 5-2 show the results of this analysis. The linked man model using equivalent handle travel distances predicts that Little Blue Lifter has the best force performance with a maximum operation force of 17 kg.

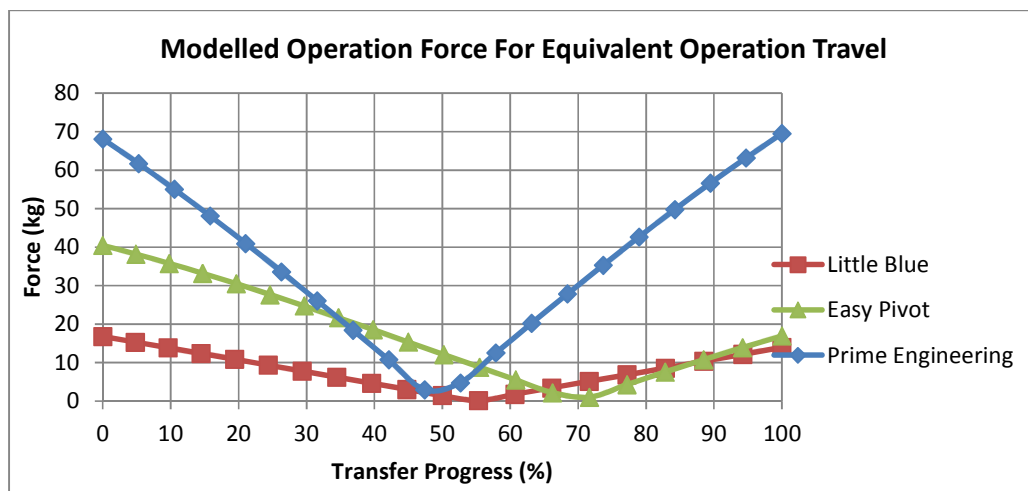

Figure 5-2 Comparison of the modelled operation force for handle lengths that produce equivalent travel distances to the little blue lifter

For the modelled handle travel, the operation force for the easy pivot and prime engineering lifter are substantially higher than the Little Blue Lifter. In practice these devices use much greater handle travel distances to bring this force down into an acceptable range. The Prime engineering lifter also partially uses the operator's weight as a counter balance to assist operation.

The safe load handling literature in chapter 1.2 suggests that energy input is also an important aspect. Figure 5-3 shows the modelled potential energy of the patient during operation. The Little Blue Lifter has substantially lower changes in the patient's potential energy during the transfer.

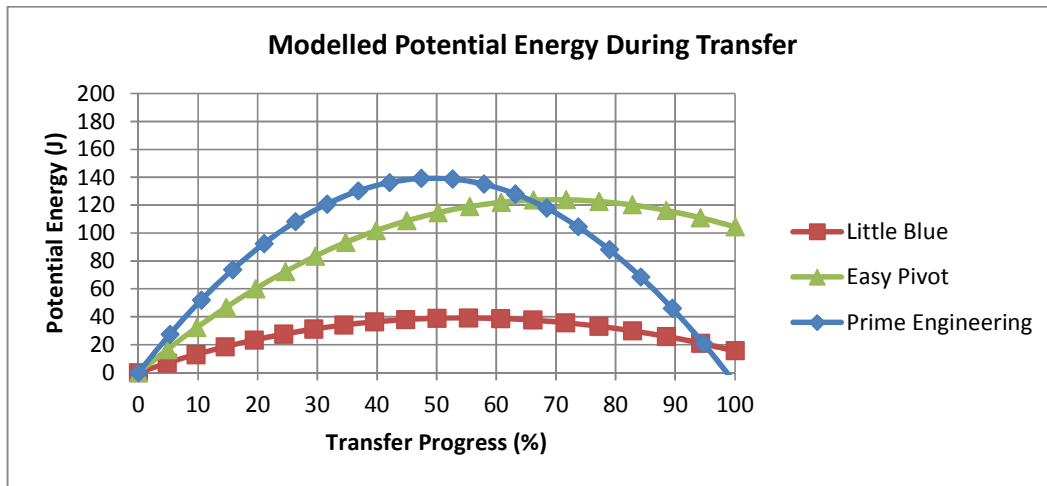

Figure 5-3 Comparison of the modelled potential energy of the patient during the transfer process

5.2 Prototype Review

The main limitation of the little blue and rocking chair lifter concepts is that the key part of the mechanism is required to be positioned behind the shins and below the thighs of the patient. This can cause the devices to be unusable for transferring from wide chairs or from a seated position on a bed.

Another potential issue for the little blue lifter in particular is the required range of motion. Trials on the multi-bar link prototype (which performs a similar motion to the little blue lifter) on elderly individuals showed occurrences of the patient not being in full contact with the chest support in the final position shown in Figure 4-7.

The rocking chair lifter overcomes the potential range of motion issues while maintaining comparable performance however this device introduces an additional potential issue of the patient being dragged across the chair. The transfer action of the rocking chair lifter is similar to that of the prime engineering lifter; in each case, as slack in the supports is taken up, the person slumps and drags across the chair (Figure 5-4). Such dragging has potential to cause the skin tear injuries mentioned in chapter 3.4.



Figure 5-4 Patient transfer showing dragging occurring mid-transfer (left) demonstrated by patient being at same height as starting position (right)

To identify further potential issues a set of informal expert appraisals were conducted. Two physiotherapists, an occupational therapist, two patient handling practitioners and an ergonomist were each shown the operation of the little blue lifter and then asked about positive and negative features of the device. Notes from these appraisals are outlined in Appendix A.

A summary of the results of these interviews confirmed many of the previously noted criteria and evaluations. However, the need for a high sense of security was further emphasised. Specific aspects which were thought to affect the sense of security were noise, appearance, the amount of physical interaction with the caregiver and the physical demands on the patient.

5.3 Concept Generation

Mechanism concepts were generated with the aid of a physical scale model of the linked-man (Figure 5-5). The physical model demonstrated a number of considerations:

- To achieve low energy transfer the centre of mass needs to move horizontally.
- If the relative angle of the linkages remains the same then the centre of mass location does not change relative to the chest.
- To prevent the patient being dragged across the chair the knee needs to be initially constrained from moving forward.
- A stable final position can be achieved with a smaller range of motion required from the patient if the knee is allowed to move forward.
- A support placed in front of the shin linkage and fixed to the torso linkage could potentially lift the feet of the patient after the shin is sufficiently inclined.

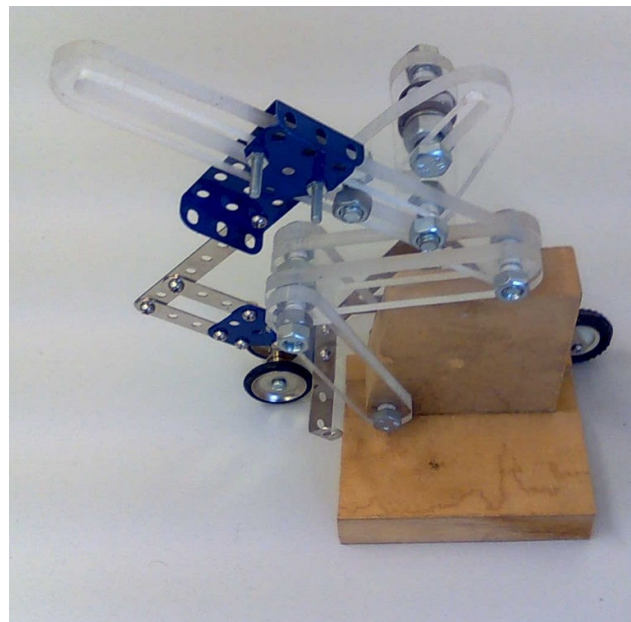

Figure 5-5 Physical scale linked man model

The most promising concept (shown in Figure 5-6) consisted of a pivoting support fixed to the torso linkage. This pivot is allowed to move horizontally to perform the transfer. A support fixed to the torso linkage provides contact that slides along the shin linkage to control the torso angle. This mechanism combines the best properties of both the little blue and rocking chair lifters and:

- Has the potential to maintain the simplicity of the little blue lifter.
- Does not require pivot points which would interfere with furniture.
- Initially constrains the knee to prevent dragging.
- Does not require as significant a range of motion ability as the little blue lifter.
- Reduces caregiver handling tasks by lifting the feet as part of normal operation.

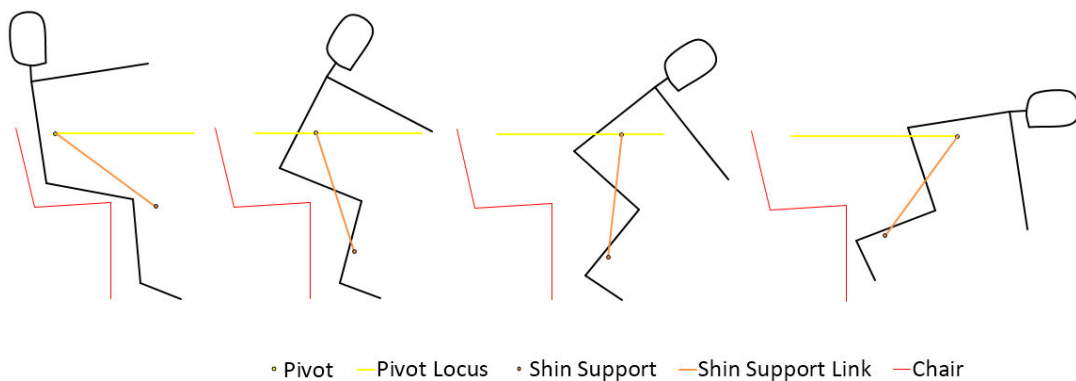

Figure 5-6 Diagram of the patient handling device concept operation from start (left) to finish (right)

5.4 Concept Modelling

Modelling was used to optimise the pivot and shin support placement. The model used with the existing devices was applied to this new concept using identical parameters and assumptions with the additions of:

- An additional movable link to represent the foot.
- A shin support located at a predefined position relative to the chest support.
- A handle located 45 degrees from the pivot and vertical which produces equivalent travel as the Little Blue Lifter during operation.
- The assumption that the torso remains fixed to the pivoting chest support.
- The assumption that the handle force is supplied in the most efficient manner.

The operation of the proof of concept mechanism was modelled in four distinct phases which are reversed when returning to the chair (shown from left to right in Figure 5-6):

- Phase one involves the shin pad being moved to contact the shin. This consists of approximately 16 degrees of the chest rotation.
- Phase two involves the lower leg pivoting about the ankle as the patient is moved forward via shin contact with the shin pad. This consists of approximately 24 degrees of the chest rotation and 30 degrees of the shin rotation.
- Phase three involves the lower leg pivoting about the ball of the foot rather than the ankle. This consists of approximately 24 degrees of the chest rotation and 20 degrees of the shin rotation.

- Phase four involves the patient's feet being lifted automatically while they are rotated into the end rest position with the patient's chest finishing rotated 90 degrees from the start position. This consists of approximately 26 degrees of the chest and shin rotation.

As opposed to the modelling of the previous patient handling devices, both the upper body centre of mass, the lower leg angle and the total centre of mass positions are significant to the operation:

- The distance and direction of the upper body centre of mass to the pivot influences the operation force in the first three phases.
- The lower leg angle influences the operation force in the second and third phase.
- The distance and direction of the total centre of mass to the pivot influences the operation force at the end to the transfer.

This along with the total centre of mass position moving relative to the torso linkage as the patient is transferred makes optimising pivot position non trivial. A trial and error approach of adjusting the pivot location and shin pad position was used.

Adjusting the shin pad location altered the angle of the shin relative to the chest. An initial shin pad location close to the knee (approximately 65 mm in front of the knee joint location) produced the lowest range of motion requirement. This shin pad location was used for all further analysis.

Adjusting the pivot location revealed four important regions (Figure 5-7):

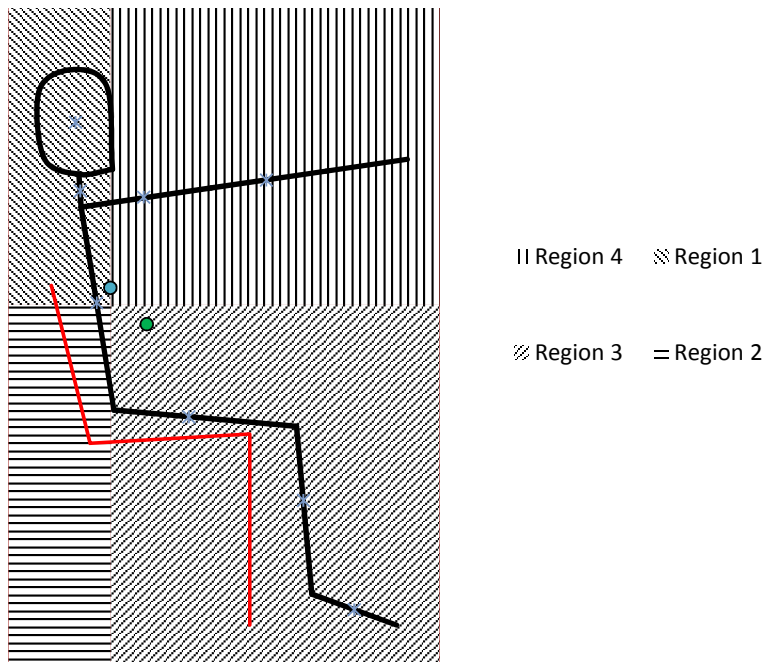

Figure 5-7 Pivot placement regions

- Region 1 is located to the left of the centre of mass of the upper body and above the final position of the total centre of mass.
- Region 2 is located to the left of the centre of mass of the upper body and below the final position of the total centre of mass.
- Region 3 is located to the right of the centre of mass of the upper body and below the final position of the total centre of mass.
- Region 4 is located to the right of the centre of mass of the upper body and above the final position of the total centre of mass.

To demonstrate the unique properties of each region a pivot located 30 mm vertically and 30 mm horizontally into each of these regions was modelled. Figure 5-8 shows the variation of the patient's potential energy during the transfer process for each of these models. Region 1, 3 and 4 give the lowest change in potential energy, less than half that of the Little Blue Lifter.

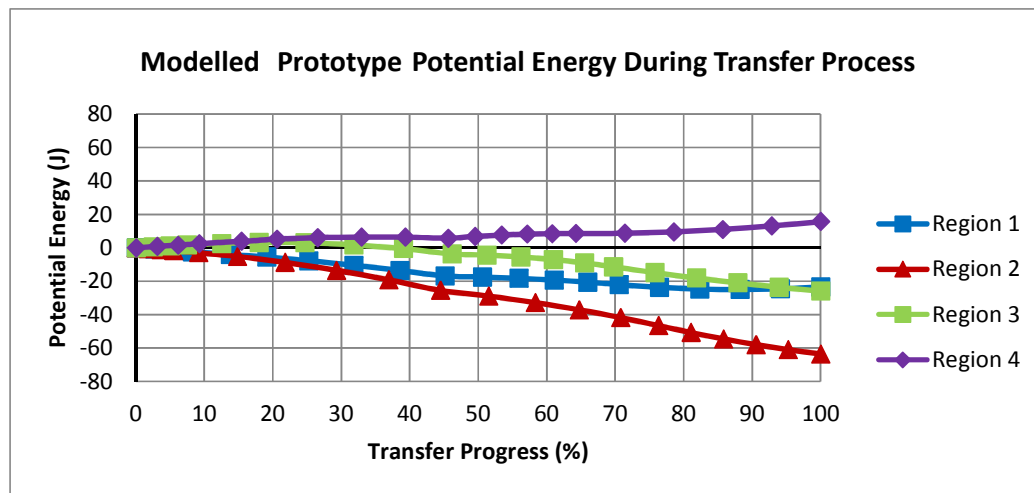

Figure 5-8 Comparison of the potential energy during the transfer for the four pivot locations

The relative shape of these curves reveals the unique properties of each of the four regions:

- A pivot located in region 1 will cause the centre of mass to descend then ascend.
- A pivot located in region 2 will cause the centre of mass to descend throughout the process.
- A pivot located in region 3 will cause the centre of mass to ascend then descend.
- A pivot located in region 4 will cause the centre of mass to ascend throughout the process.

Figure 5-9 shows the total operation force for the four modelled pivot locations at key parts of the transfer progress. A pivot located in region 3 requires the least operation force at these key points in the process with a maximum force of 8.7 kg at the end of phase 4. A pivot located in region 2 results in generally higher operation force throughout due to a greater distance from the upper body and total centre of masses.

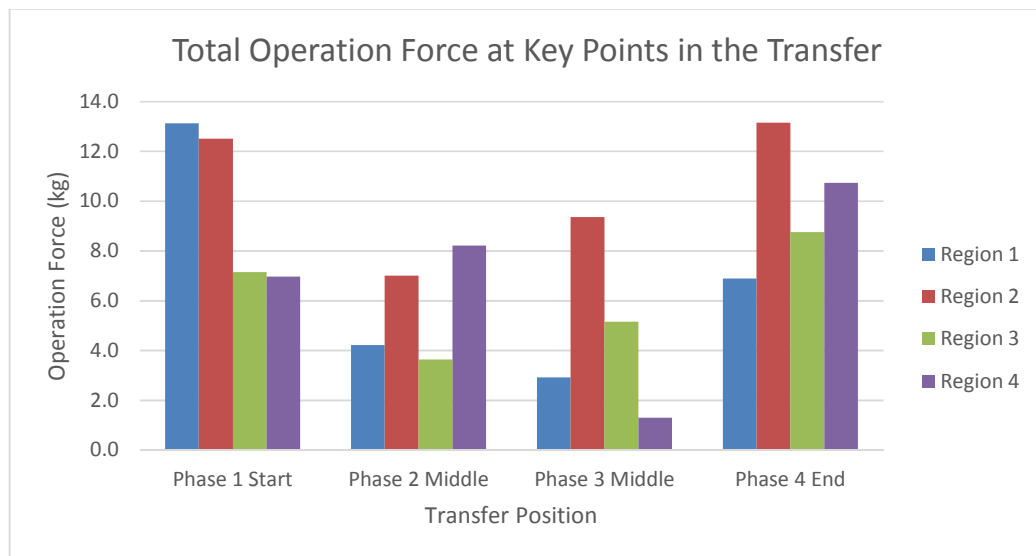

Figure 5-9 Total operation force for pivots located in the four important regions

Not all of the operation force contributes to the change in potential energy. Figure 5-10 shows the component of this force which is tangential to the direction of travel of the handle which contributes to work done. Figure 5-11 shows the component of force normal to the direction of travel which is required to hold the device in place at times when it is under constrained. A negative tangential force indicates force in the on-chair travel direction. A negative normal force indicate force towards the pivot.

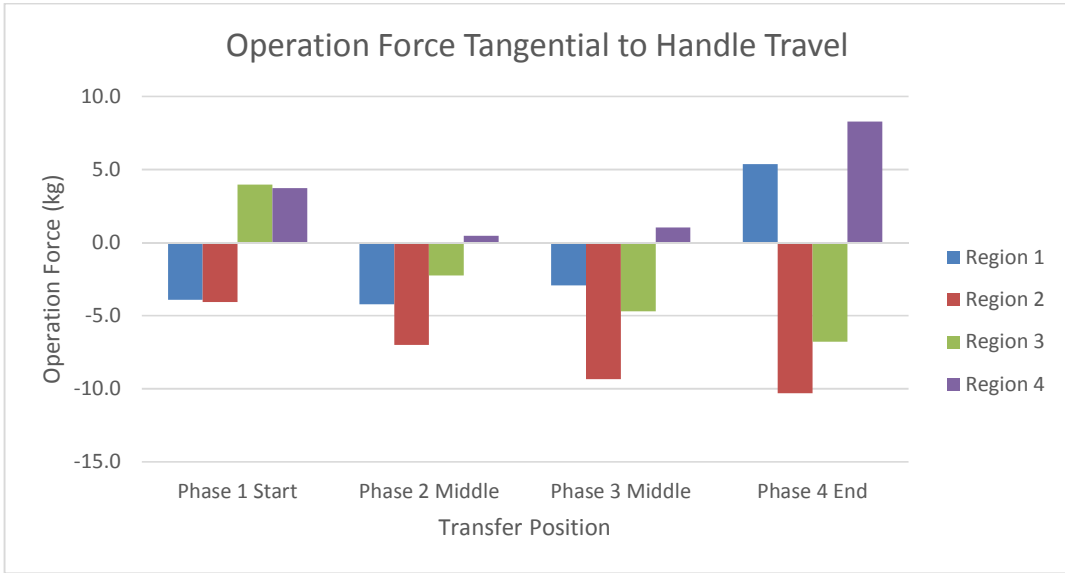

Figure 5-10 Tangential operation force component for each region at key points in the transfer process

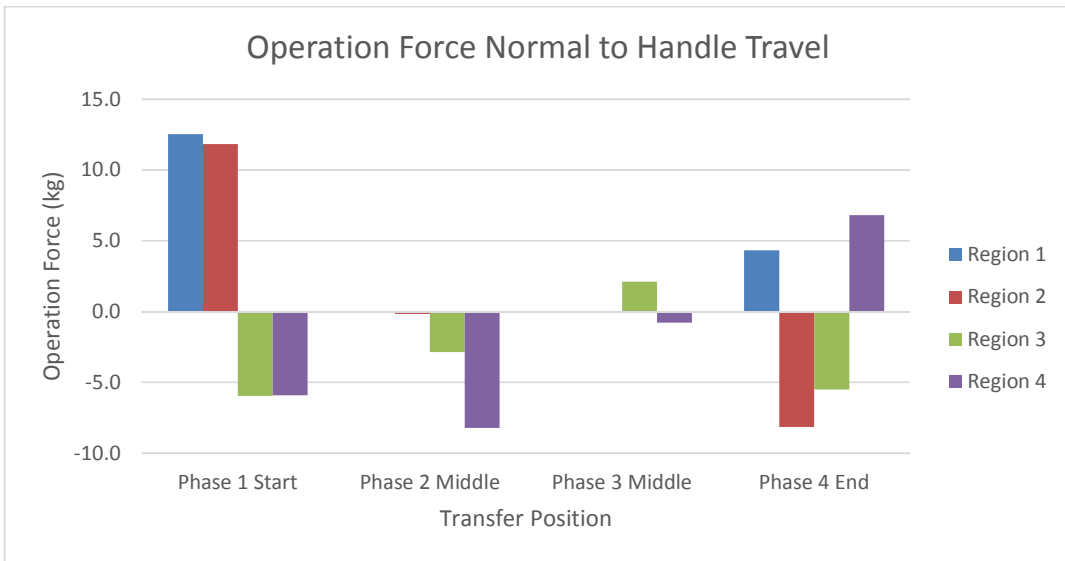

Figure 5-11 Normal operation force component for each region at key points in the transfer process

The tangential operation force shows a similar trend as the potential energy in Figure 5-8.

- A pivot located in region 1 requires tangential force in the on-chair direction for the first three phases and in the off-chair direction for the final phase.
- A pivot located in region 2 requires increasing tangential force in the on-chair direction as the transfer progresses.
- A pivot located in region 3 requires operation force in the off-chair direction for the first phases and in the on-chair direction for the final three phases.
- A pivot located in region 4 requires tangential force in the off-chair direction.

Phase 1 has a high normal force requirement, this force is needed to prevent the patient's knee from moving. Pivots located in regions 1 and 2 have a higher normal force than in regions 3 and 4 due to the force required to prevent the shin moving and the force required to rotate the chest being partially in the same direction. If the starting shin angle is inverted this situation would be reversed.

Pivots located in regions 3 and 4 require downwards force to be applied to prevent loss of contact between the shins and shin pad. Pivots in regions 1 and 2 do not require this because the moment from the upper body centre of mass forces the shin pad to contact the shins.

The normal force in phase 4 for all regions is due to the handle being angled downwards at 45 degrees. A force in the vertical direction is required.

A pivot located in region 3 was found to be most favourable. The shape of potential energy fluctuation in this region (ascending then descending) means that the patient will naturally stay in either the un-transferred or fully transferred state, which should lower the chance of a patient fall due to latch failure. Also, the closeness of the pivot to both the upper body and total centre of mass points allows this region to have greater potential to have reduced force.

Trial and error of pivots in this region discovered that a pivot 30 mm horizontally from the intersection of the regions produced the lowest force. Figure 5-12 shows the modelled operation force for this adjustment with a peak operation force of 6 kg at the end of phase 2. This result indicates that an operation force lower than the 10 kg goal is possible with this concept when used with a Little Blue equivalent handle.

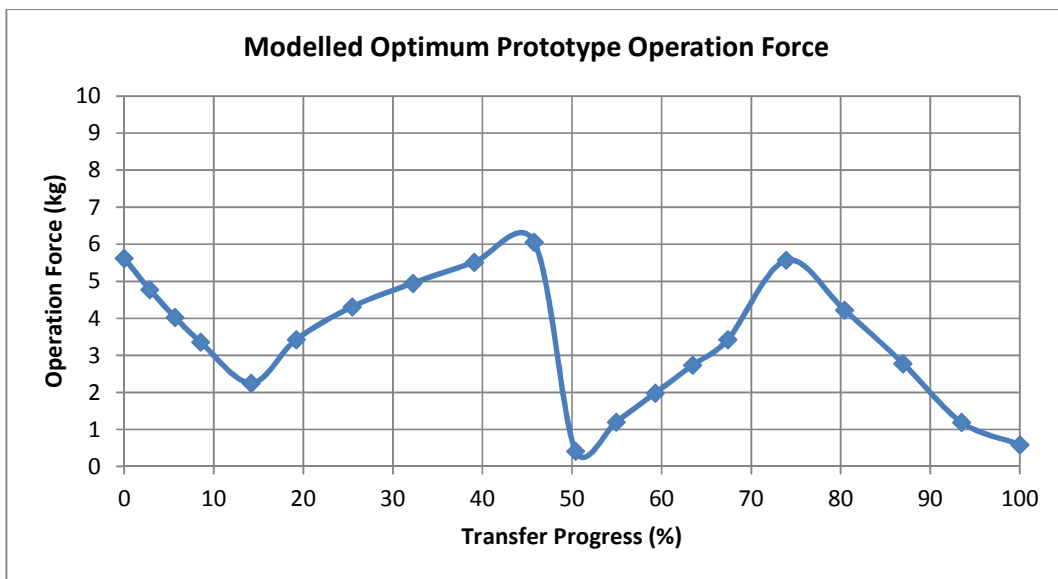

Figure 5-12 Optimum operation force

5.5 Design Overview

To test the concept, a robust adjustable device was necessary. Features of the device are shown in Figure 5-13 and are described in further detail below.

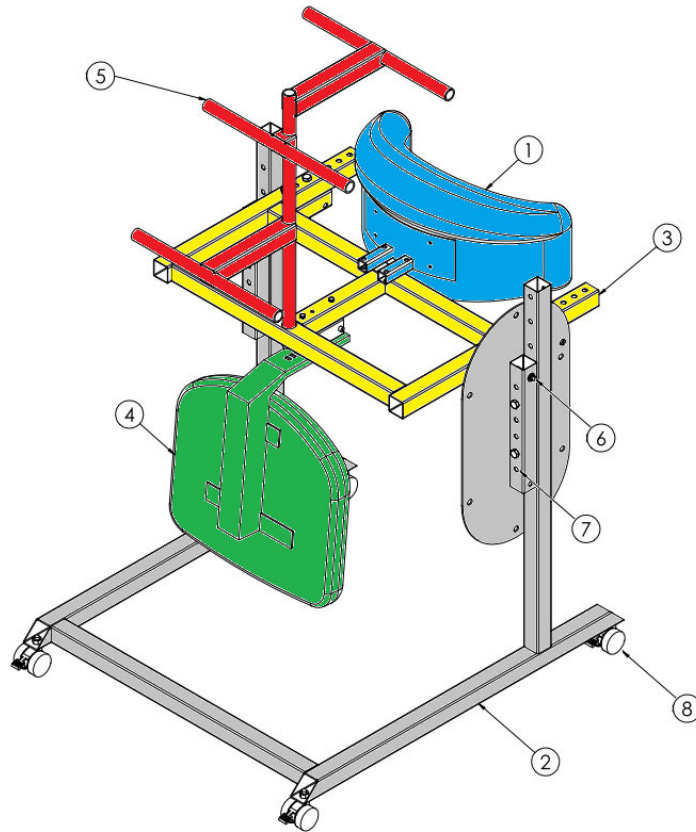

Figure 5-13 Novel patient handling device mechanism overview

Frame (Items 2 & 3): The frame was made at a size significantly larger than necessary to ensure the mechanism did not interfere with the test subjects or chair.

Pivot (Item 6): The pivot consisted of an 11mm machined steel pin running in drilled hole with a normal running fit. The additional friction resulting from this bearing type was insignificant.

Adjustment (Item 7): Adjustment is necessary to account for variation in how the person rests in the supports and possible differences in anthropometry from the modelled values which will consequently alter the centre of mass locations. The adjustment was achieved by a series of holes in the main frame and a series of holes in an adjustment boss at different spacing. The result was such that through combinations of bolt locations and orientations of the adjustment boss, 5mm increments could be made for the perpendicular distance from the chest to the pivot and 10mm increments could be made in pivot height.

Wheels (Item 8): The wheels were selected to be commercial grade furniture casters, as these would allow easy positioning on the hard surfaces used for testing and are low in cost.

Chest Support (Item 1): An existing prototype chest pad was used. This support consisted of a padded hoop designed to rest under the arms and on the upper chest.

Shin Support (Item 4): The shin support consisted of a repurposed office chair seat. The adjustment of the position of this was achieved by spacers and holes in the pivoting frame.

Handle (Item 5): A handle length for a travel equivalent to the Little Blue Lifter placed the handle in an impractical location. Instead three grips of greater distance from the pivot were used. The three grips were designed to allow the caregiver to control the device in a comfortable position throughout the operation.

5.6 Operation

The previously mentioned four phases of operation are shown with the proof of concept mechanism in the following figures. Figure 5-14 shows phase one of operation with the shin pad being moved to contact the shin. Figure 5-15 shows the second phase of operation with the lower leg pivoting about the ankle as the patient is moved forward. Figure 5-16 shows the third phase of operation with the lower leg pivoting about the ball of the foot as the patient is moved forward. Figure 5-17 show the final phase with the legs being lifted as the patient moves into the rest position.



Figure 5-14 Mechanism operation phase
1



Figure 5-15 Mechanism operation phase
2

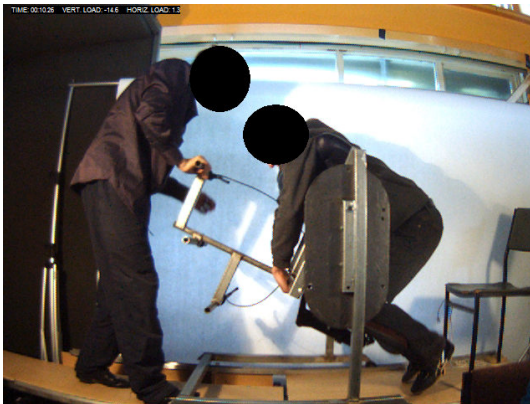

Figure 5-16 Mechanism operation phase
3



Figure 5-17 Mechanism operation phase
4

6 Mechanism Testing

The proposed concept was predicted to reduce handling tasks and require less than 10 kg of operation force with a Little Blue Lifter equivalent handle when adjusted optimally. Testing was undertaken to verify if these predicted properties could be achieved in practice and if the linked man model is useful for optimising the transfer process. Testing also allowed areas which have potential to be improved to be observed.

The tests were undertaken by observing the normal operation of the device during a complete off-chair and on-chair cycle while measuring the operation force. Five test subjects were used to act as patients to observe how the device operates with different anthropometries. These test subjects also acted as caregivers to observe what operation techniques were adopted. Two pivot positions were used with these test subjects to observe the sensitivity of pivot placement.

Table 6-1 Primary characteristics of test subjects

Test Subject	1	2	3	4	5
Height (mm)	1910	1750	1650	1860	1780
Weight (kg)	102	67.7	74	68.6	65.9

The height and weight of the test subjects used is shown in Table 6-1. Linkage mass and length data was unable to be collected. When necessary this was assumed to be of the same proportions as for the 50th percentile man/woman from the previously used anthropometric data.

The configuration of the device as used for the testing is shown in Figure 6-1. The two different adjustments used varied the value of X shown on the figure. For adjustment 1, X = 207 mm and for adjustment 2, X = 147 mm. These adjustments aimed to give a pivot location close to the centre of mass of the test patients but were not optimised.

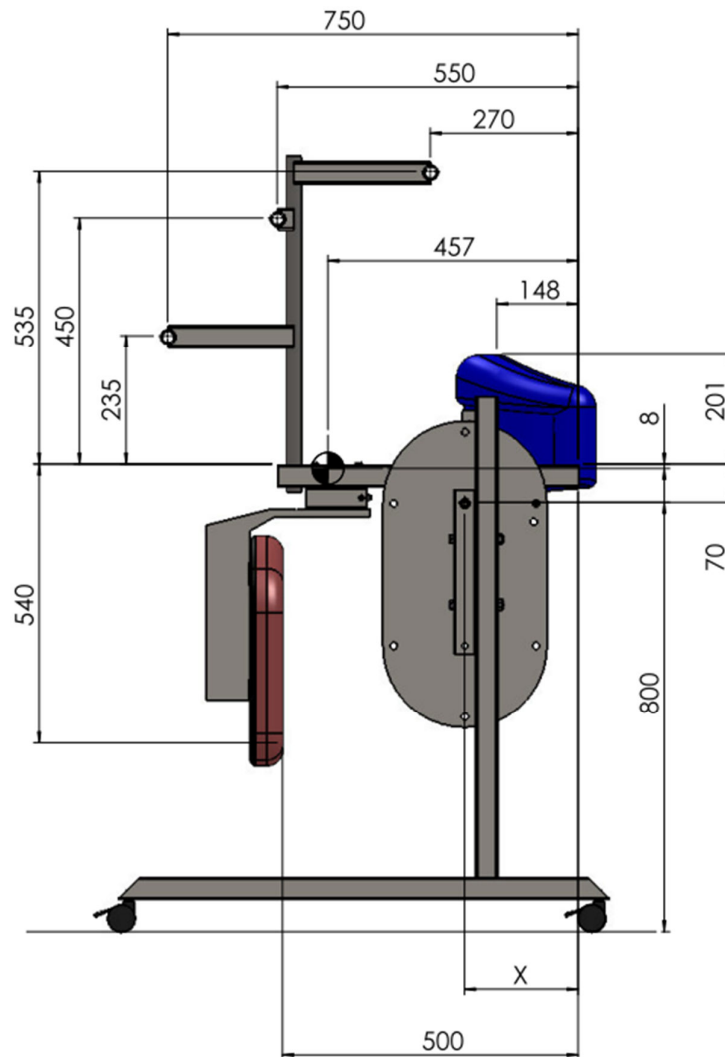

Figure 6-1 Device configuration used for testing

6.1 Apparatus

The operation force was measured by measuring the force the caregiver transfers through the ground. This was achieved by the operator standing on a force balance platform (Figure 6-2) throughout the transfer progress. This force balance platform was isolated from the patient and patient handling device. The force balance platform continuously measured the force from the caregiver in both the vertical and horizontal directions.



Figure 6-2 Force balance platform

The platform rested on four calibrated shear beam load cells orientated to measure loads in the vertical direction. These vertical load cells were in turn fixed to a frame which was suspended from steel strips to allow low friction travel in the horizontal direction. The suspended frame is supported from one side by a calibrated s-type load cell and on the opposing side by springs preloaded to 20 kg of force, allowing horizontal forces of up to 20 kg to be measured in both directions. A diagram of this configuration is shown in Figure 6-3.

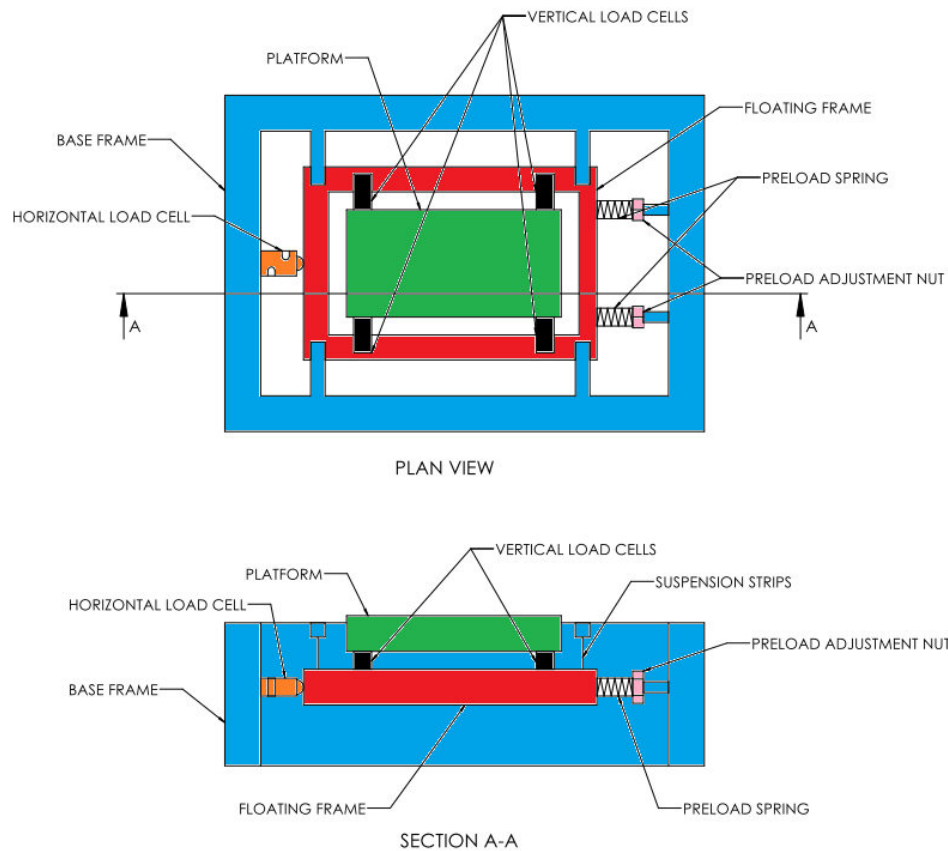

Figure 6-3 Force balance platform schematic

For purposes of testing the patient handling device was fixed to travel in one direction aligned with the horizontal direction of the force platform. This was achieved by running the casters of the patient handling device in a pair of close fitting channels which were isolated from the force platform.

The chair used for transferring to and from was a fixed height office chair of height 460 mm at the front and inclined at an angle of 3.6° . The chair and rails were mounted on a support to align the height and travel with the force platform while not interfering with force measurement.

A commercial grade 640x480 resolution camera was used to record images during the transfer process. The camera was placed in a fixed position of approximately 1.6 meters distance from the patient handling device.

6.2 Testing Process

For each test situation a systematic testing process was used involving the following steps:

- The height and weight of the test patient was measured.
- The test patient was asked to sit naturally on the chair.
- The test caregiver was instructed to stand still on the force platform and the force readings were zeroed.
- Recording of images and forces was commenced with photos taken at intervals of 0.2 seconds and force reading averaged over the time preceding the photo.
- The test caregiver presented the device to the test patient and instructed them to hold onto the chest support yet otherwise remain passive.
- The test caregiver was instructed to smoothly perform a transfer from the chair, move the test patient in the transfer position and then return the test patient to the seated position.
- The sequence was repeated three times for each test patient with both patient handling device adjustments.

6.3 Analysis Method

To test the usefulness of the model, the position of the patient's joints and the device needed to be measured. This was achieved by photogrammetry. The angles and position of the device was collected programmatically using known reference lengths on the device for calibration while the joints were found by estimating their locations manually.

The cameras images presented significant barrel distortion. To correct this distortion a reference image of a uniform pattern was taken with the camera (Figure 6-4). A Matlab algorithm was then used to determine the transformation which converted the distorted pattern to the uniform original. The transformation was then applied to the original test images.

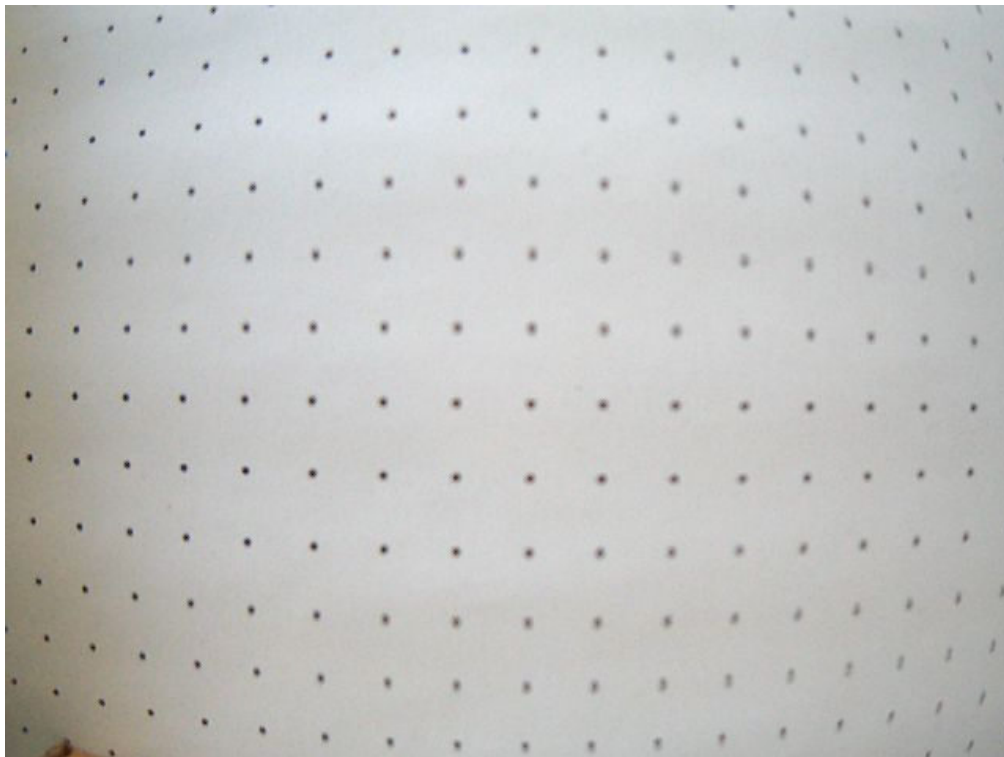

Figure 6-4 Barrel distorted reference image

Additionally due to the closeness of the camera to the object a large amount of perspective distortion was present. This distortion was corrected by measuring known lengths of the device and applying a Matlab algorithm to the test images. A comparison of the original image to the correct image is shown in Figure 6-5.



Figure 6-5 Comparison of the original image (top) and corrected image (bottom)

Due to the closeness of the camera and the location of the joints being in a different plane to references on the device there was parallax error. To account for this error, points of reference on the device were projected onto the same plane as the joints. This projection was achieved with two steps:

- The location of the equivalent device reference on the other side of the device was found in the image.
- The proportion of the distance between the device reference and joint reference frame to the device width was estimated.

The projected point was defined as being located at the above proportion along the line connecting the above device reference points.

The model also required adjustment. The self-weight of the device significantly affects the centre of mass locations. This frame mass of 16 kg was assumed to be fixed to the chest, the location is indicated by the centre of gravity symbol on Figure 6-1.

The device was operated in a dynamic fashion which resulted some of the operation force going towards overcoming inertia and friction. This was assumed to be negligible.

6.4 Results

The designed patient handling device mechanism was able to successfully perform a transfer. The handling task reduction provided by the mechanism, the operation force reduction provided by the mechanism, the efficacy of the model at optimising pivot placement and additional observations during operation of the device are described below.

6.4.1 Handling Task Reduction

The mechanism was able to successfully lift the test patient's feet reliably during operation for all test patients. With the use of the under arm support the resulting average operation time was 9 seconds for transferring off the chair and 6 seconds for returning to the chair for a total average transfer time of 15 seconds.

A number of potential issues were observed from the act of lifting the feet automatically:

- Patients tended initially to want to lift their legs further up the shin pad, which would adversely affect the on-chair transfer.
- It was difficult to accurately place the patient correctly in the chair, there was no feedback as to where the correct position to lower the feet was.
- It was particularly difficult to return shorter patients to the chair as the patient's thigh would contact the seat edge (Figure 6-6).



Figure 6-6 Thigh contacting the edge of seat when returning to the chair with a shorter test patient

6.4.2 Operation Force Reduction

An aim of the device was to require less than 10 kg of operation force. Modelling predicted that this could be achieved with the concept.

Table 6-2 Maximum operation force for each test patient and adjustment

	Max Operation Force (kg)			
	Adjustment 1		Adjustment 2	
	Off-chair	On-chair	Off-chair	On-chair
Test Patient 1	22.7	17.0	13.9	15.6
Test Patient 2	16.9	11.6	9.1	10.3
Test Patient 3	13.0	15.3	11.7	10.5
Test Patient 4	9.7	12.6	8.3	10.5
Test Patient 5	11.8	10.5	8.4	8.4

6.4.3

An aim of the device was to require less than 10 kg of operation force. Modelling predicted that this could be achieved with the concept.

Table 6-2 shows the maximum measured operation force for each test patient and adjustment separated into an off chair and on chair process. Three test patients required less than 10 kg of operation force to be transferred off the chair, only one of these (test patient 5) met this goal for returning to the chair. Only test patient 4 achieved less than 10 kg operation force for adjustment 1 in the off chair direction and none did for the on-chair direction.

Changing the pivot location from adjustment 1 to 2 decreased the operation force for all test patients. This improvement was particularly apparent for patient 1, with the off chair operation force decreasing by approximately 40% (Figure 6-7). Patient 3 was affected the least with operation force decreasing by approximately 5% (Figure 6-8). For both these adjustments taller and lighter patients appear to require less operation force.

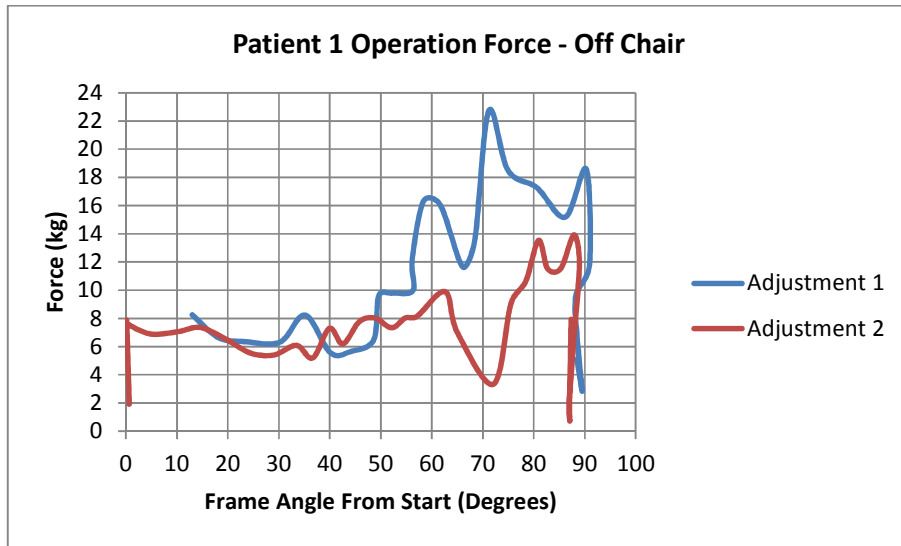

Figure 6-7 Variation in operation force between each pivot location for patient 1

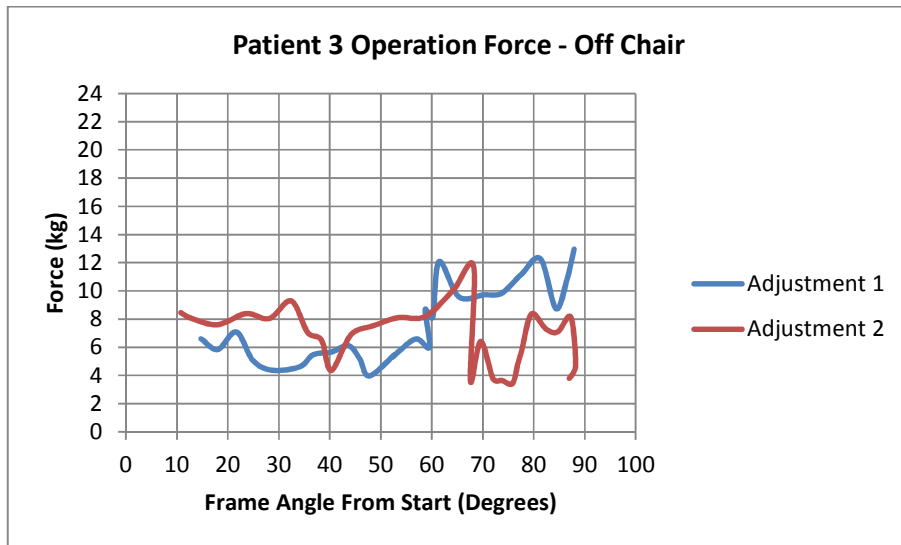

Figure 6-8 Variation in operation force between each pivot location for patient 3

6.4.4 Model Efficacy

Many simplifying assumption were used to create the linked man model which may affect its usefulness for optimising the transfer process. Comparison between the modelled and measured forces allows the usefulness to be identified.

The direct measured force readings are unsuitable for comparison as they contain significant fluctuation. The operation force varied between repeated operations by as much as 4 kg. Two separate off-chair transfers for test patient 2 and adjustment 2 with this variation are shown in Figure 6-9. This fluctuation is predominately arises in force inefficiently applied normal to the direction of travel of the handle.

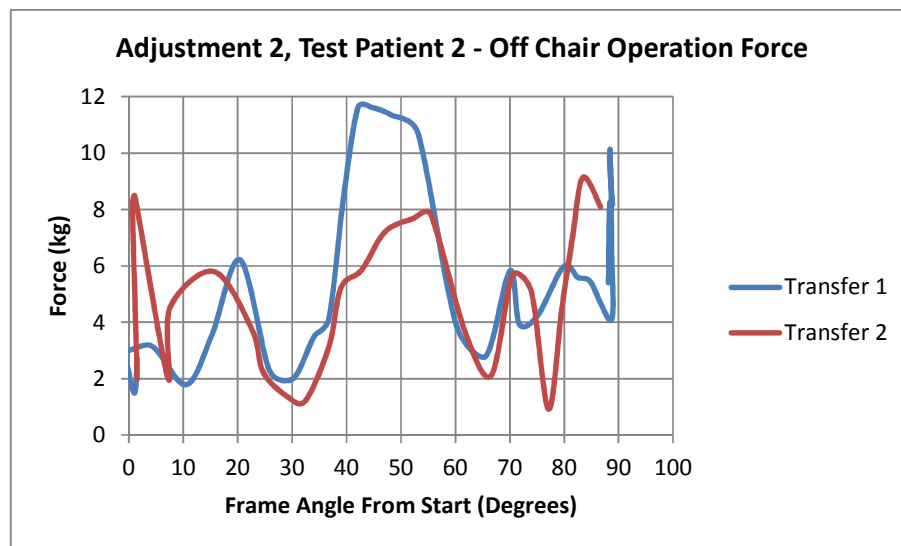

Figure 6-9 Variation in operation force between repeated transfers

To remove this issue the tangential operation force was compared (Figure 6-10). The modelled force initially conforms closely to the measured results but subsequently diverges.

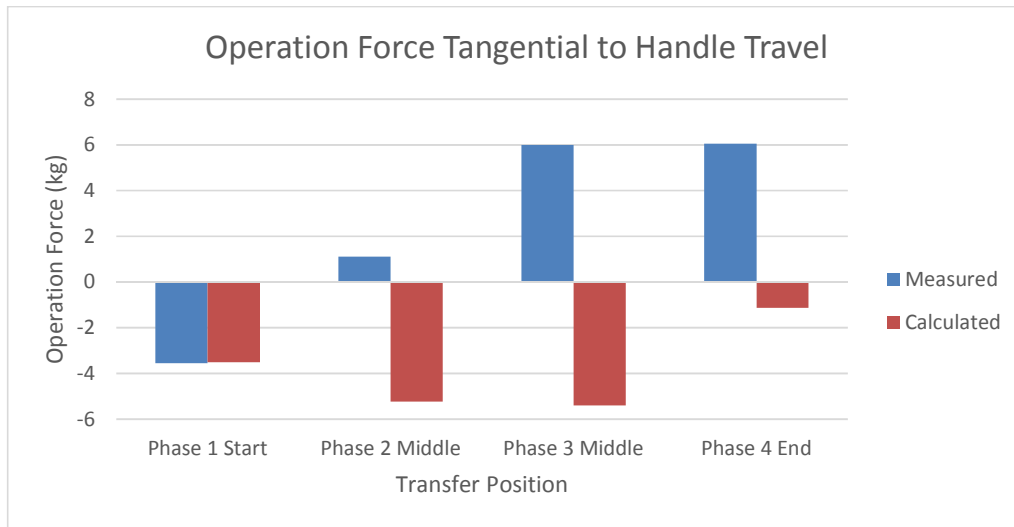

Figure 6-10 Comparison of modelling and measured tangential operation force

6.4.5 Additional Observations

The angles of the patient's linkages varied from the assumed values used for modelling due to slumping and rotation about the chest pad.

- Phase one consists of approximately 10 degrees of the chest rotation and 16 degrees of device rotation.
- Phase two consists of approximately 20 degrees of the chest rotation, 10 degrees of the shin rotation and 22 degrees of device rotation.
- Phase three consists of approximately 26 degrees of the chest rotation, 42 degrees of the shin rotation and 32 degrees of device rotation.
- Phase four consists of approximately 11 degrees of the chest, shin and device rotation.

The final chest angle was found to be comfortable at an angle of approximately 60 degrees from vertical. A transfer involving 90 degrees of rotation, which was modelled, is not necessary.

The caregivers would often continue to grip two handles at once (Figure 6-11). Such a grip was potentially ergonomically unsound due to the required posture.



Figure 6-11 Handle usage adopted by some test caregivers

Although Inertia and friction were assumed to be negligible a high force was observed between the off chair and on chair processes (Figure 6-12). This could have had an influence on the measured operation force.

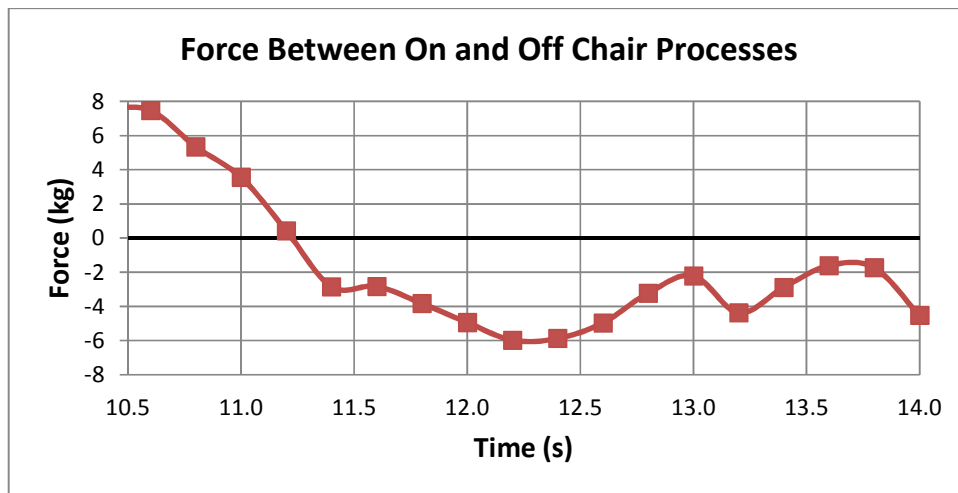

Figure 6-12 Plot of operation force after off chair operation is complete

6.5 Conclusions

The results show a number of promising attributes of the designed patient handling device mechanism and a number of issues were highlighted. The implications of these results are described below.

6.5.1 Handling Task Reduction

The operation time is significantly shorter than all other methods which have been tested by previous research. Particularly significant was it being faster than manual lifting processes. This concept shows promise in reducing transfer times, providing that an acceptable support can be developed.

The mechanism automatically lifting the feet likely helped in producing this low operation time, however it created issues when returning the patient to the chair. Lowering the feet in the correct location was difficult and would be affected if the patient moved their feet up the shin pad. Additional mechanisms to automate this process could solve this issue.

When the feet are lowered in the correct location returning to the chair is still difficult, particularly for shorter patients. This is mainly due to significant slumping and rotation about the chest support which leaves the patient in an unfavourable posture. This may be solved with a more secure support system.

6.5.2 Operation Force Reduction

Without optimisation the operation force was below the 10 kg target for a number of the tests. In the worst case the force was still below that of the Easy Pivot device. It may be possible to reduce the operation force further by optimising the pivot location for each individual.

Returning to the chair required more force, the main reason for this is explained in the section above though a further issue which may have contributed was that the most effective way to apply force was not intuitive. This issue was largely due to unexpected flexing of test patients, which forced the operator to control both the angle and position of the device in all phases. Greater support of the patient and additional mechanisms to control the device more securely could resolve this issue.

The results suggest in general that the pivot should be lowered and be moved to a horizontal location between adjustment 1 and 2. This is particularly visible for patient 3 whose force was not as greatly improved by moving the pivot to adjustment 2.

6.5.3 Model Efficacy

The comparison between the measured and modelled tangential force initially showed close conformance however as the transfer progresses these values diverge. The measured results suggest the pivot is located in region 1 while the model predicts that the pivot is located in region 2. To achieve a similar operation force the modelled centre of mass positions would need to be approximately 30 mm lower. The estimation of segment lengths varied by up to 40 mm between images, which may explain a large component of the error. It is also possible that the assumed anthropometric mass proportions are not valid for test patient 2.

Despite these discrepancies, the model may still be used to optimise the pivot location. The model suggested that a pivot located in region 3 will require lower forces. For this patient the model suggests the pivot needs to be lowered and moved further away from the chest to move from region 1 to 3.

6.5.4 Additional Observations

Linkage angles closer to those planned for in the model may be achieved by using a more secure support. Although the posture did not adversely affect operation by a noticeable amount.

Phase one has high device rotation, thus handle travel, without rotating the patient. This is possibly wasted movement which increases the potential energy change. A shin pad located closer to the shins initially could reduce this.

The travel of the handle could be further reduced by finishing the process at a more upright chest angle. Reducing the handle travel allows higher leverage to be used without requiring excessive motion by the caregiver, or a large number of grips.

The highest friction and inertia force would occur between the on and off chair processes as there is a change in direction required and the most load is supported by the wheels. With the measurements available it is difficult to measure the influence this would have during operation. Attempts were made to compensate for friction and inertia which resulted in little change to total operation force and the predicted pivot region, thus the initial assumption appears to be valid.

6.6 Recommendations

6.6.1 Testing and Measurement

While this measurement method was adequate for a proof of concept study it can be improved in a number of ways:

- A camera of higher quality and placed further away from the subject would reduce barrel distortion, perspective distortion and parallax effects which would speed up analysis.
- Easily identifiable markers placed at the test patients joint locations and on points of interest on the device would allow the analysis process to be automated to a greater extent which would speed up analysis.
- Rails and wheels of higher quality would reduce friction which would make the results more consistent.
- Static testing could be undertaken at discrete points in the operation. This would remove the effect of inertia, the caregivers stepping, and allow friction to be more easily compensated for.

6.6.2 Mechanism

A number of areas for improvement of the device were identified:

- The device needs to be such that a force does not need to be applied to hold the shin support in place. This need for additional force made operation difficult and there was little feedback for how to apply force in the most efficient direction.
- A chest pad that more rigidly supports the chest would provide a more reliable control of the patient's position. This control would allow the patient to be returned to the chair closer to their original position and would ensure the pivot is more consistently in the desired location relative to the chest.
- A method for aiding the placement of the patient's feet is needed to ensure the patient is returned to the seat correctly.
- The handle needs to be design so that it is intuitive of the caregiver to use properly

7 Support Development

The review of existing supports revealed that most supports require the placement of straps either under the legs or behind the back. In particular, existing forward tilting mechanisms described in chapter 4.1 all required the placement of a support under the legs and behind the back which can be a difficult and time consuming task.

The research in chapter 2 suggests that placing slings under the patient can be stressful to the caregiver and a significant factor in the time taken to operate a device. Such a device is unlikely to be used, regardless of whether or not it reduces the forces required for patient transfers.

The aim of this initial support design was to investigate:

- If a patient was able to be supported comfortably without straps under the legs or behind the back.
- Which aspects of a support are necessary.
- How the support may be made to suit a wide range of patients.

7.1 Prototype Review

The most promising previous support developed by the University of Canterbury involved supporting the patient underneath their upper arm and relying on their strength to hold themselves on the device during operation (Figure 4-16). This concept had the advantage of requiring no assistance from the career and being fast.

This concept was evaluated by an informal expert appraisal by two physiotherapists, an occupational therapist, two patient handling practitioners and an ergonomist. These appraisals resulted in a general consensus that the support would be unsuitable for a large number of patients. Reasons for this were varied:

- Many patients would be unable to lift their arms over the support.
- The area supported is sensitive.
- A large amount of strength is required from an area which may be weak.
- It bears similarity to a dangerous manual lifting technique which has been postulated to have caused a number of injuries on patients (Lloyd 1997).

This indicates that a new support method needs to be developed for use on low effort devices.

7.2 Concept

The proposed solution was to create a support which covers the entire front, side and arms of the author in a close fitting fashion (Figure 7-1). It was thought that by having a large area of close fitting support the support force could be spread over a larger area than for the previous support designs and the pressures could be lowered.

The position of the arms was chosen to be approximately in the middle of a normal range of motion. This posture can be achieved by a large number of people. For the purposes of development it was unnecessary for the support to be attached to a transfer device. Since the part of the transfer which is most adverse to patient comfort is in the initial phase with the torso predominately upright, the comfort in this upright position is of most interest.



Figure 7-1 Close fitting support concept in use

7.3 Construction

To create a close fitting support plaster castings were taken of the author. These castings were then wrapped in 10mm flexible foam padding and used as a pattern to cast an expanding rigid polyurethane support in a wooden frame. Encased nuts were dispersed amongst the rigid foam to allow segments of padding to be removed and replaced. The resulting support is shown in Figure 7-2.



Figure 7-2 Distributed support concept

8 Support Testing

Three separate qualitative subjective tests were undertaken with the enclosure support concept. The first was to determine if, with all the padding present, the support pressure could be spread over a large area and achieve comfort. The second was to determine if the arms by themselves could provide enough support comfortably in the devised posture. Finally the possibility of using only the thorax enclosure with mild clamping was investigated.

8.1 First Test

The original intention was for the contour to match closely however when load was applied the flexibility of the body meant that the patient slipped into a different position. This slipping resulted in a large proportion of the load resting on the inner arms (Figure 8-1).



Figure 8-1 High pressure area (circled)

This inner arm region is highly sensitive and a large amount of discomfort was felt. This discomfort was mitigated by inclining the support forward at an angle (Figure 8-2) so that a higher proportion of the load was applied at the forearms and frontal thorax region. Another way was by using physical strength to decrease the amount by which the shoulders are slumped, lifting the body off the high pressure region.



Figure 8-2 Inclined position of support

8.2 Second Test

For the second test substantial padding was removed from the inner arm area which caused discomfort in the first test. Additionally, padding to the rear of the torso was removed so that only the arms were used for support (Figure 8-3).

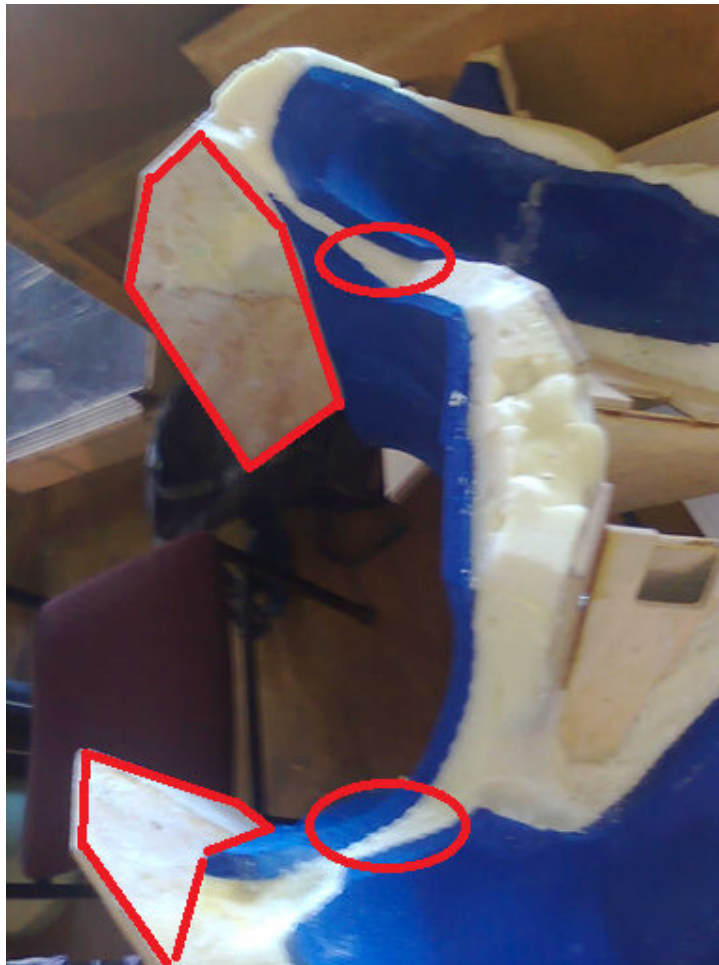

Figure 8-3 Support padding configuration for the second test (removed areas shown in red)

Even after the large amount of padding was removed substantial slumping of the shoulders still resulted in pressure on the sensitive upper inner arm, though it was easier to physically decrease the amount of slumping and decrease this pressure. The level of strength required with the proposed posture appeared to be higher than that required of the under arm support in chapter 4.2.5.

Without the rear padding it became clear that support was needed to the upper rear of the torso to prevent the patient's upper chest from being moved away from the support. Support in this area may make entry more difficult without adding additional mechanisms.

8.3 Third Test

For the third test, support material was moved from the centre-line of the support allowing each side of the support to be moved inwards, towards the centre and padding to the rear of the torso was replaced (Figure 8-4). With this system the support could be opened sideways to allow entry then clamping could be applied by means of a ratcheting F-clamp.



Figure 8-4 Support padding configuration for third test

With this setup it was found that the entire bodyweight could be supported providing that some of the slack in the padding material was taken up such that the supports fitted closely around the torso. The arms did not need to be in position and no physical exertion was required of the patient. The load appeared to be concentrated between the front of the chest and the lower rear of the thorax (Figure 8-5). The level of pressure felt comparable to that of the under arm support in chapter 4.2.5.

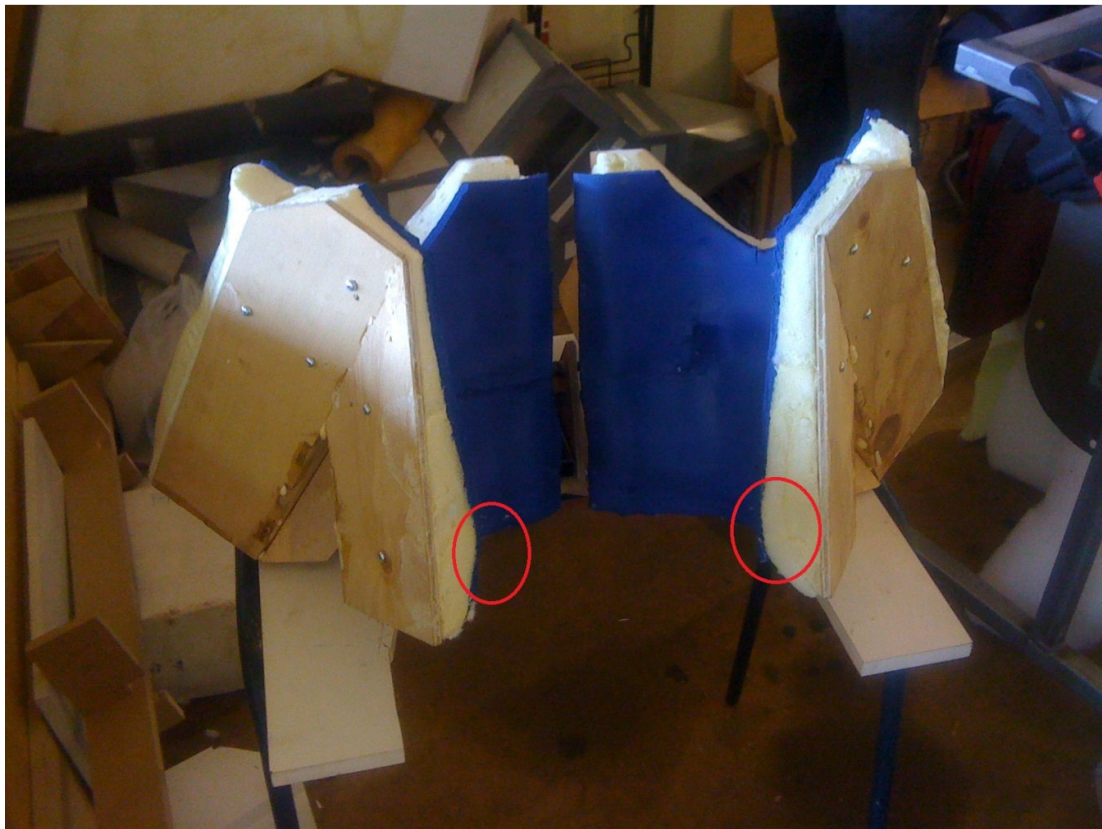

Figure 8-5 location of main gripping area on the rear side of the support (circled)

8.4 Discussion

The original concept of distributing the support load over a large area was shown to be unfeasible due to the patient being flexible and shifting from the planned support position. It may be possible for the concept to work if the support is made to be equally as flexible as the patient, but this has not yet been attempted.

The use of the arms to support the patient in the posture chosen was also shown to be unfeasible in this configuration. The chosen posture made it was more physically difficult and less comfortable to support the patient weight than with the under arm support. Load applied to the forearms was found to be more comfortable than beneath the upper arms so it may still be possible to alter the posture such that this feature can be used.

The most significant result of the testing was that a patient could be supported around the lower thorax without relying on the patient's strength (Figure 8-6). To achieve this lower thorax support close fitting padding is needed in the area shown in Figure 8-5. Although the feasibility of this has been established the current support system is not in a practical format. The support system needs to be appropriately connected to a patient handling device and incorporate a clamping mechanism.



Figure 8-6 Test patient supported by lower thorax padding

9 Conclusion

This thesis explored the development of a patient handling device for the home care environment, which is easy enough to be used by caregivers who may be physically impaired. Existing patient handling devices were reviewed and found to have many deficiencies for this home care environment.

- All current devices are slow; some require transfer times up to 200 seconds per direction.
- Many transfer devices require high operation force, some up to 30 kg of force.
- All commercial devices substantially raise the centre of mass of the patient.
- Many of the devices are bulky, making storage and transportation difficult, particularly the mobile sling hoist.
- All commercial devices require a number of additional handling tasks before the transfer and these have been found in some cases to be rated as difficult as a manual transfer.

A mechanism was developed to address these issues. This mechanism consisted of a rigidly connected upper body support and shin support attached to a linearly travelling base frame by a single pivot. The pivot is located close to the centre of mass of the patient which ensures little energy is expended during a transfer. This mechanism was successful in addressing all the issues with existing devices.

- The operation time was less than 9 seconds each direction.
- The force was less than 10 kg when adjusted close to the optimal pivot location.
- The device changes the centre of mass height very little.
- The device supports the patient from beneath and involves only a single moving part so may be made compact.
- The mechanism automatically lifts the patient's feet during operation, reducing handling tasks.

The mechanism device does however rely on a suitable upper body support being developed and issues may arise with chairs of differing height.

A potential suitable method of support was demonstrated which uses close fitting support around the lower torso. Supporting in such an area may provide sufficient comfort without requiring physical strength. A mechanism for the support is required which can cause it to fit snugly about these areas with minimal caregiver intervention.

10 Recommendations for Further Research

Of particular interest is:

- Refine the existing patient handling device mechanism and determine its effectiveness in real life situations, particularly the effect of different height chairs that may be encountered.
- Determine the factors which affect the caregiver's perceived effort when operating patient handling devices and their relative importance.
- Determining the limiting physical capabilities of patients and caregivers.
- Develop a systematic way of determining the effectiveness and comfort of existing supports and how it may be improved.

11 References

- ACC (2003) The New Zealand Patient Handling Guidelines, *retrieved from* http://www.acc.co.nz/PRD_EXT_CSMP/groups/external_ip/documents/guide/pi00212.pdf.
- ACC (2012) Moving and Handling People: The New Zealand Guidelines 2012, *retrieved from* <http://www.acc.co.nz/preventing-injuries/at-work/industry-specific-safety/moving-and-handling-people-nz-guidelines/index.htm>.
- Anderson, C. K., D. B. Chaffin, G. D. Herrin and L. S. Matthews (1985) A biomechanical model of the lumbosacral joint during lifting activities, *Journal of Biomechanics* **18**(8): 571-584.
- Basbaum, A. I. and C. J. Woolf (1999) Pain, *CURRENT BIOLOGY* **9**(12): R429-R431.
- Bass, M. J. and L. G. Phillips (2007) Pressure Sores, *Current Problems in Surgery* **44**(2): 101-143.
- Bell, F., M. E. Dalgity, M. J. Fennell and R. C. Aitken (1979) Hospital ward patient-lifting tasks, *Ergonomics* **22**(11): 1257-1273.
- Benbow, M. (2009) Skin tears, *Journal of Community Nursing* **23**(1): 14-18.
- Chaffin, D. B. and K. S. Park (1973) A longitudinal study of low back pain as associated with occupational weight lifting factors, *American Industrial Hygiene Association Journal* **34**(12): 513-525.
- Clavet, H., P. C. Hébert, D. Fergusson, S. Doucette and G. Trudel (2008) Joint contracture following prolonged stay in the intensive care unit, *CMAJ : Canadian Medical Association journal = journal de l'Association medicale canadienne* **178**(6): 691-697.
- Fransson-Hall, C. and A. Kilbom (1993) Sensitivity of the hand to surface pressure, *Applied ergonomics* **24**(3): 181-189.
- Garg, A., B. Owen, D. Beller and J. Banaag (1991) A biomechanical and ergonomic evaluation of patient transferring tasks: bed to wheelchair and wheelchair to bed, *Ergonomics* **34**(3): 289-312.
- Health and Safety Executive (1992) Manual Handling, *retrieved from* <http://www.legislation.gov.uk/ukxi/1992/2793/contents/made>.
- IASP. (2014) IASP Taxonomy website, <http://www.iasp-pain.org/Education/Content.aspx?ItemNumber=1698#Painthreshold>.
- ISO (2006). Hoists for the transfer of disabled persons -- Requirements and test methods. **ISO 10535:2006**.
- Jensen, R. C. (1987) Disabling back injuries among nursing personnel: research needs and justification, *Research in nursing & health* **10**(1): 29-38.

- Kinsler, A. M., W. A. Sands and M. H. Stone (2009) Reliability and validity of a pressure algometer, *Journal of strength and conditioning research / National Strength & Conditioning Association* **23**(1): 312-314.
- Le Bon, C. and C. Forrester (1997) An ergonomic evaluation of a patient handling device: the elevate and transfer vehicle, *Applied ergonomics* **28**(5-6): 365-374.
- Leblanc, K. and S. Baranoski (2009) Prevention and management of skin tears, *Advances in skin & wound care* **22**(7): 325-331.
- Lloyd, P. (1997) The guide to the handling of patients, *National Back Pain Association*.
- M.O.H. (2001) Living with Disability in New Zealand, *retrieved from*
- Martini, F., J. L. Nath and E. F. Bartholomew (2009) Fundamentals of anatomy & physiology, *San Francisco, Calif, Pearson Education Inc.*
- Medica-Works. (2014) Medica Works website, <http://www.medicaworks.com/>.
- Melloni, B. J. (1998) Melloni's illustrated dictionary of the musculoskeletal system, *New York, Parthenon Pub. Group.*
- Owen, B. D. (1985) The Lifting Process and Back Injury in Hospital Nursing Personnel, *Western Journal of Nursing Research* **7**(4): 445-459.
- Oxford Dictionary of English (2010). Deconditioning, Oxford University Press.
- Pheasant, S. (1986) Bodyspace: anthropometry, ergonomics, and design, *Taylor & Francis.*
- Prime-Engineering. (2014) Prime Engineering website, <http://www.primeengineering.com>.
- Rand-Scot. (2014) EasyPivot Patient Lift Website, <http://www.randscot.com>.
- Roach, K. E. and T. P. Miles (1991) NORMAL HIP AND KNEE ACTIVE RANGE OF MOTION - THE RELATIONSHIP TO AGE, *PHYSICAL THERAPY* **71**(9): 656-665.
- Rolfson, R. P. (2004) The design, biomechanics and ergonomics of a novel patient lifting interface, *Dissertation/Thesis, ProQuest, UMI Dissertations Publishing.*
- Roth, P. T., J. Ciecka, E. C. Wood and R. Taylor (1993) Evaluation of a unique mechanical client lift: efficiency and perspectives of nursing staff, *AAOHN journal : official journal of the American Association of Occupational Health Nurses* **41**(5): 229.
- Shrier, I. and K. Gossal (2000) Myths and truths of stretching - Individualized recommendations for healthy muscles, *PHYSICIAN AND SPORTSMEDICINE* **28**(8): 57-63.
- Statistics New Zealand (2013) Disability Survey: 2013, *retrieved from* http://www.stats.govt.nz/browse_for_stats/health/disabilities/DisabilitySurvey_HOTP2013.aspx.
- SureHands. (2014) SureHands Body Support Website, (2014), <http://www.surehands.com/products/surehands-body-support/>.

Tortora, G. J. and B. Derrickson (2014) Principles of anatomy & physiology.

Van Herp, G., P. Rowe, P. Salter and J. P. Paul (2000) Three-dimensional lumbar spinal kinematics: a study of range of movement in 100 healthy subjects aged 20 to 60+ years, *Rheumatology (Oxford, England)* **39**(12): 1337-1340.

Waters, T. R., V. Putz-Anderson, A. Garg and L. J. Fine (1993) Revised NIOSH equation for the design and evaluation of manual lifting tasks, *Ergonomics* **36**(7): 749-776.

Woolf, C. J. (2010) What is this thing called pain?, *The Journal of clinical investigation* **120**(11): 3742-3744.

Yeziarski, R. P. (2012) The Effects of Age on Pain Sensitivity: Preclinical Studies, *Pain Medicine* **13**(2): S27-S36.

Appendix A Patient Handling Expert Interview - Summary

Three interviews undertaken with patient handling experts. The first interview was with Mary Thomson (Physiotherapist), Joanna Hegarty (Physiotherapist) and Jess Vallance (Occupational Therapist) on the 14th of November 2011. The second interview was with Val Gallon-Carter (Charge Nurse) and Prof. Tim Wilkinson (Consultant geriatrician) on the 17th of November 2011. The third interview was with Sue Alexander (ergonomists) on the 19th of March 2012.

Questions were prepared in advance however many were found to be irrelevant. Much of the useful information was obtained from additional questions which arose during the course of the interviews but were not recorded. The outcomes are the author's interpretation of what was talked about in the interview and may not reflect exactly what was said.

First Interview

Prepared Questions:

- What are the limitations of patients requiring transfer assistance?
- How is the range of motion of patients limited?
- What loads are permissible on patients and how is this affected by strength?
- What is the optimum place/orientation for applying loads?
- How is the load transferred through the patient with conventional hoists?
- How are the capabilities of patients assessed?
- What are the requirements of existing standing/toileting hoists?

Outcomes:

Patient Characteristics:

- A rest home of 600 would have enough demand for a device which is similar to the little blue lifter.
- The conditions of elderly patients are often combined and hard to categorise, trial and error testing to see if device is suitable is recommended.
- Stroke patients would require central grips to compensate for likely asymmetry in their strength.
- Recommended design device for a specific condition then test how many can use it.
- Arthritis and general weakness are common in the elderly.
- Core muscles are commonly weak.
- Elderly commonly rely on their arms to help them stand.

Range of motion:

- Flexibility of knees less than 90 degrees is common with elderly patients
- Lifting arms above shoulder height is commonly difficult for elderly
- Rotor cuff injuries may prevent the patients arms from being lifted above the shoulder

Patient load capacity / existing device loads:

- Existing standing hoist require patient to be weight bearing, found by trial and error.
- Devices called turners are used which require significant upper body strength, which is acceptable.
- Optimal manual lifting involves lifting under the buttocks.
- Using the shoulders may be risky, wouldn't look secure.

Second Interview

Prepared Questions:

- What patient conditions require assistance with transfers and what approximate proportion are they in?
- Is there any particular condition/characteristic patient which/who should be designed for?
- If so, what are the limitations of this patient?
- What loads are applied to patients currently?
- How are the loads determined to be safe?
- What are the strong and weak features of the shoulder?
- Are there any guidelines on patient comfort during transfers?
- Can you recommend any other sources of information?

Outcomes:

Patient Characteristics:

- Common condition requiring assistance with transfer is a de-conditioned patient (general weakness).
- The severity of the condition is more important than the type of condition.
- Elderly patients are more likely to develop weakness in their legs before other areas.

Range of Motion:

- Low flexibility of legs is common, unable to bend less than 90 degrees between shin and thighs.
- Low flexibility of arms is common, unable to lift above shoulder.
- Rotor cuff injuries prevent the arm from being moved, joint is very unstable.

Patient Load Capacity:

- Safety of device for patient is determined by physio.
- No major limitations with applying load to the chest other than colostomy bags and similar medical aids which may be located there.
- Belts around the chest cut into the patient which is uncomfortable.
- The shoulder joint is unstable and lifting under the arms is uncomfortable.
- A patient is weight bearing if they are in no pain while in a standing position.
- May be research on patient comfort during intensive care and transfers in bed.

Third Interview

Prepared Questions:

- What are the most important parts of the specialist knowledge of movement and biomechanics that allow a technique to be selected?
- How are physiotherapists trained on the requirements of patient handling devices?
- What information would be needed for training with new devices?
- How do you determine comfort?
- What are the main parameters affecting comfort,
- How is it related to time
- What are some key ways comfort may be improved

Outcomes:

Under Arm Lifting:

- There are two main problems with lifting around the axilla:
 - There are many nerves under the arm that could be easily damaged
 - The shoulder may be dislocated from the load
- Additionally it is general difficult for the elderly to lift their arms
- Possible solution is to use the forearm to support. Advantages are:
 - doesn't require arms to be lifted
 - less sensitive to pressure
 - downward arms are more possibly more stable
 - currently used for many standing hoists
- Disadvantage is
 - It may cause shoulder to hunch, although hunching could be used as an indication of the device being unsuitable.

Ergonomics:

- The key to ergonomics and patient comfort is to make the device fit the patient well, i.e. removing pressure points with contoured shapes.
- Anthropometric data can be used to achieve this. Sources are:
 - The New Zealand anthropometric data from Otago University.
 - Stephen Pheasant (U.K.) (Bodyspace : anthropometry, ergonomics, and design / Stephen Pheasant.)
- There are no rules for maximum pressure and comfort, although more area and less load is better

Prescribing use of the device:

- Current transfer technology may show typical patients and have a checklist or table to show where a device fits on continuum of dependence to independence.
- Physios would need general trials to demonstrate the devices usefulness and will form their own opinions on when it is suitable based on their training and experience. No technical information will be able to influence this.
- New requirements with new technology will be intuitive and will not cause issues with patient profiles.

General:

- Weight bearing with a bent knee is more difficult.
- The form of the device may be the one of the most significant factors to the device being specified.
- Interacting directly with the patient may be beneficial