

Compact Fluorescent Lamps (CFL) – Implications for Distribution Networks

Neville R. Watson
University of Canterbury

Tas Scott and Stephen Hirsch
Orion N.Z. Ltd

Abstract

The desire to reduce electrical loading by using energy efficient lighting has resulted in a high level of interest in replacing conventional incandescent lamps with Compact Fluorescent Lamps (CFL). CFLs are however, a nonlinear load hence inject harmonics into the electrical network. The CFL use electronic ballasts and the design of these have an enormous impact on the electrical performance of the CFL. In the past the harmonics injected into the network by CFLs has been ignored as each is very small as the typically CFL is only 20 Watts. However if widespread adoption of CFLs occurs the combined effect of all these small sources can be just as detrimental as one large source, and is even harder to mitigate due to their distributed nature. This paper presents the results of a study to quantify the effect widespread adoption of CFLs will have on a typical distribution network. The two aspects investigated were harmonic distortion and system losses.

1. Introduction

One of the obvious ways to use electricity more efficiently is by using energy efficient lighting such as Compact Fluorescent Lamps (CFL) to replace conventional incandescent lamps. The electronic ballasts of CFLs are nonlinear, and hence a current waveform that is rich in harmonics is drawn. This harmonic current flowing in the network causes a power quality issue as these harmonic currents flowing through the system will distort the voltage waveform.

The impact of harmonics flowing in electrical networks is diverse and often subtle. Destruction of power-factor capacitors and the malfunction of equipment, such as crawling of motors, and telephone interference are readily apparent. However, reduction of equipment lifetime is not apparent and often erratic behaviour of equipment compels costly upgrade of production equipment without the real cause, voltage distortion, being identified. For example capacitors connected to the network have lower impedance the higher the frequency, and the harmonic currents can easily cause the destruction of capacitors in the network. Moreover some equipment, such as PLCs (Programmable Logic Controllers), are adversely affected by voltage distortion and will exhibit erratic behaviour (due to the time dependent nature of the harmonic distortion) or completely malfunction.

In the past the harmonics injected into the network by CFLs has been ignored as each CFL's injection is very small. The combined effect however, of the widespread adoption of CFLs can be just as detrimental as one large harmonic source. Moreover mitigation of the harmonic distortion caused by CFLs is very difficult once in the network due to the dispersed nature. Having one large harmonic source, such as a converter is easier to deal with than a multitude for small dispersed harmonic sources, as harmonic filters can be designed to meet the system requirements and installed at the devices terminals. This means that ensuring problems do not arise is very important as action after the event is not practical. The main way of achieving this is by ensuring the CFLs installed have the lowest level of harmonic injection that is practically possible at a reasonable price. This paper presents the implications for distribution

networks for widespread adoption of CFLs in terms of losses and power quality. In order to quantify the effect of this widespread use of CFLs a typical overhead line distribution system and a typical underground distribution system are modelled with different classes of CFLs deployed.

2. Simulation Studies

2.1 Distribution System

Figure 1 displays the distribution system used to represent a typical distribution system in New Zealand. This system has 15 customers supplied by each LV distribution feeder. In order to make the model manageable the model lumps all 15 customers (and their service mains) being supplied at the end of the LV feeder, when in fact they are distributed along the LV feeder. To model the distributed nature would require a node for every connection point and unduly complicate the model. This lumping of the customers will result in an over-estimation of the losses in the LV feeder (as the total current from the 15 customers flows through the whole feeder in the model), however, for the system upstream the model will give the correct results. It is possible to take the results from this study (terminal condition at sending and of LV feeder) post-process using the distributed model to obtain a more accurate estimate of the loss. Four LV feeders are supplied by each 300kVA distribution transformer. There are ten 300kVA distribution transformers connected to each 11 kV feeder. Eight 11 kV feeders are supplied by each zone substation. Six zone substations are supplied from the 33kV busbar at the GXP.

Hence in this model 28,800 ($=15 \times 4 \times 8 \times 6$) customers are modelled. The system is assumed balanced hence a per-phase model is used rather than a 3-phase model. Therefore the houses are assumed to be distributed equal between the 3-phases. However, for presentation purposes the values are converted to 3-phase powers. The house loading is assumed to be 3 kW (linear load) in addition to the lighting load.

2.2 Compact Fluorescent Lamps

The harmonics injected by the CFL were determined from laboratory measurements. The laboratory measurements of a large number of CFLs show they fall into three categories, i.e.

- a) Those that comply with Table 3 (or almost) in AS/NZS 61000-3-2, called **Good CFLs**.
- b) Those that fail this but comply with the alternative criteria (conduction and 3rd & 5th limit), called **Average CFLs**.
- c) Those that don't comply with anything, called **Poor CFLs**.

Additional simulations are performed of a fictitious CFL that just complies with Table 3 of AS/NZS 61000-3-2¹ (given in Appendix A). Figures 2 & 3 display the time waveform and spectral components for these CFLs. There is another class of CFL ballast using active power-factor conditioning but these are not available in New Zealand at present. They achieve a current THD of less than 10%.

All the CFLs have a nominal 20W rating however the actual laboratory test results are used which differ slightly. The current drawn by the different CFL differs substantially. For the

¹ Note that this is compliance with Table 3 in AS/NZS61000-3-2 which is the intent of this standard. It should be noted that AS/NZS61000-3-2 has a loophole, which allows manufacturers to claim compliance without meeting these levels. This loophole was not in this standard's predecessor AS3134 (1991).

50 Hz load-flow an impedance model is used for the CFLs. This is an approximation however is used as it avoids the need for an iterative procedure. Hence the current drawn is a function of the terminal voltages. Hence, the results presented are based on laboratory results and scaled by voltage to give the expected loading. No diversity factor has been included.

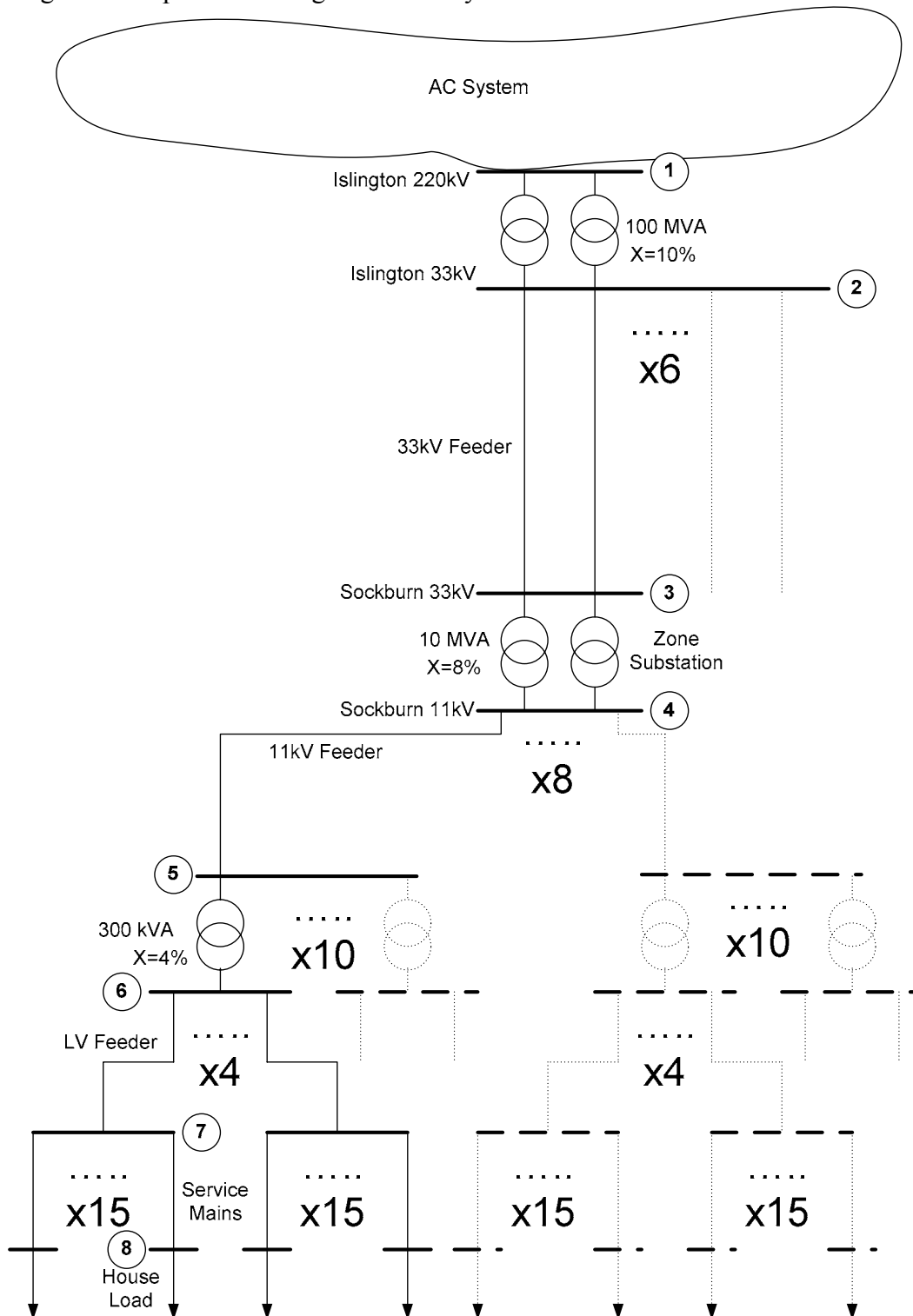

Figure 1. Test Distribution System

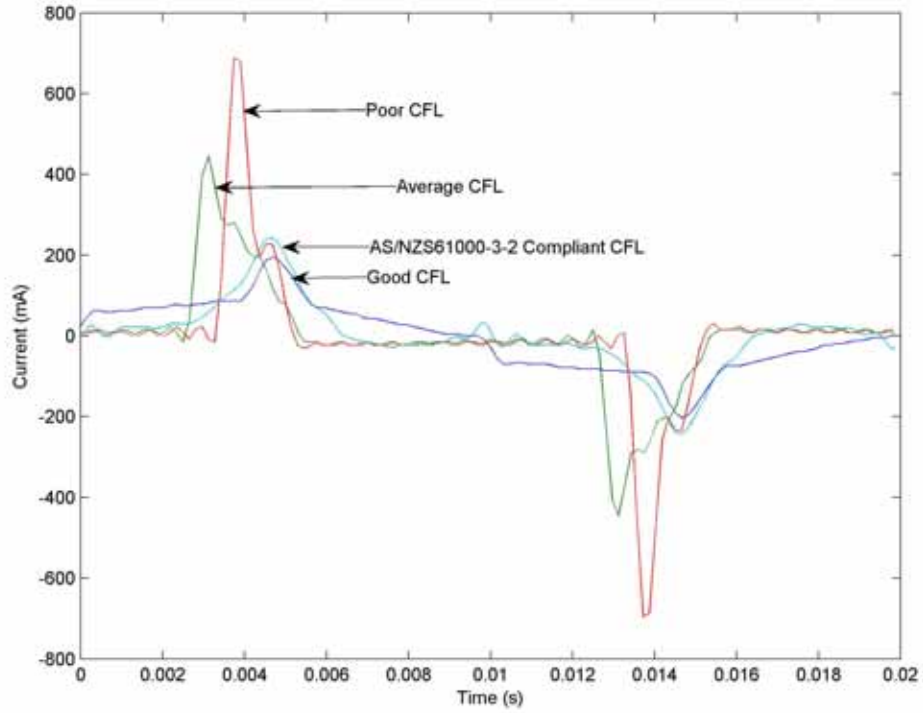

Figure 2. Time Waveform for CFLs

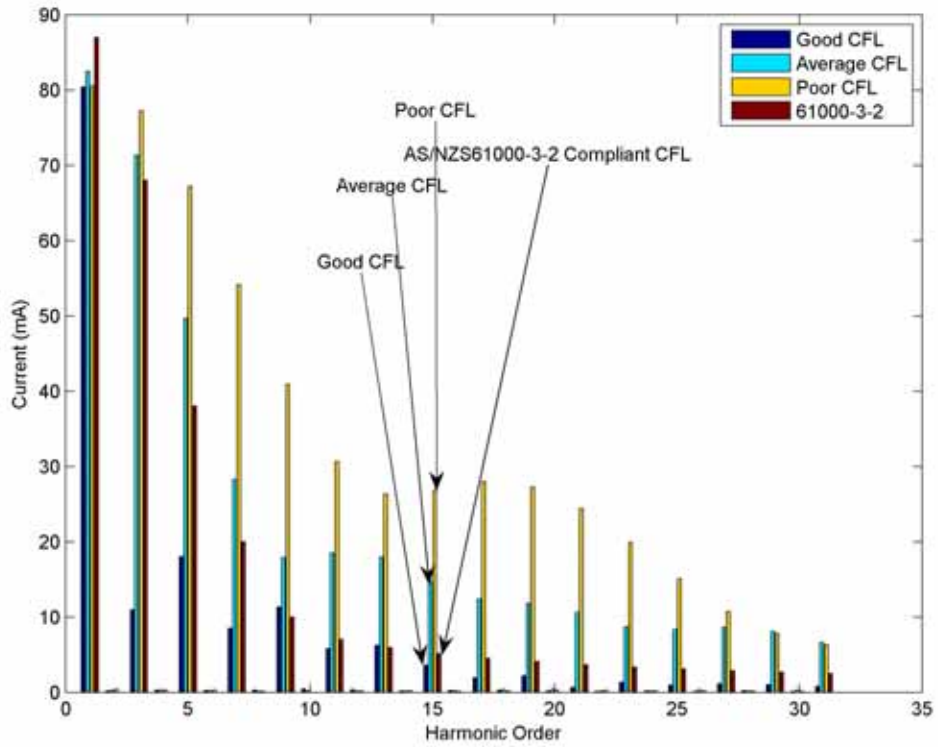

Figure 3. Harmonic Current Levels for CFLs

2.3 Methodology of Modelling

In order correctly model the combined effect of many small sources all the sources must be represented. The modelling of all explicitly is prohibitive therefore their effect must be represented by a Norton equivalent. This is achieved by starting with a Norton equivalent for the house, which includes the harmonic currents that are injected by the house load. The Service Mains is added to the Norton to give a new Norton as seen from the start of the Service Mains. This is then multiplied by the number of service mains and combined with the LV distribution line/cable to give a Norton equivalent as seen from the start of the LV distribution line/cable. The four LV distribution lines/cables are combined and the 11 kV/400V distribution transformer added to form a new Norton. This process is continued to give equivalent Norton equivalents for the down-stream distribution system for all levels. The system simulated, shown in Figure 4, models one branch of the distribution system in detail while the effect of all the other feeders is represented by their Norton equivalents. Therefore the effect of 28,800 customers is modelled in one simulation model (with the simplification of not modelling the distributed nature of the customers along the LV feeders).

Two distribution systems are modelled: Under-ground system and Overhead line. These are modelled by choosing the appropriate electrical parameters for the branches. Note that each frequency is analysed individually and the model differs. The main difference, depicted in Figure 5, is the effect of winding configuration on the flow of zero sequence harmonics.

A linear set of simultaneous equations is set up for each harmonic frequency and solved, i.e.

$$\begin{bmatrix} y_{11} & y_{12} & y_{13} & y_{14} & y_{15} & y_{16} & y_{17} & y_{18} \\ y_{21} & y_{22} & y_{23} & y_{24} & y_{25} & y_{26} & y_{27} & y_{28} \\ y_{31} & y_{32} & y_{33} & y_{34} & y_{35} & y_{36} & y_{37} & y_{38} \\ y_{41} & y_{42} & y_{43} & y_{44} & y_{45} & y_{46} & y_{47} & y_{48} \\ y_{51} & y_{52} & y_{53} & y_{54} & y_{55} & y_{31} & y_{57} & y_{58} \\ y_{61} & y_{62} & y_{63} & y_{64} & y_{56} & y_{31} & y_{67} & y_{68} \\ y_{71} & y_{72} & y_{73} & y_{74} & y_{57} & y_{31} & y_{77} & y_{78} \\ y_{81} & y_{82} & y_{83} & y_{84} & y_{58} & y_{31} & y_{78} & y_{88} \end{bmatrix} \begin{pmatrix} V_1 \\ V_2 \\ V_3 \\ V_4 \\ V_5 \\ V_6 \\ V_7 \\ V_8 \end{pmatrix} = \begin{pmatrix} 0 \\ 5 \times I_{Norton_{33kV_Feeder}} \\ 0 \\ 7 \times I_{Norton_{11kV_Feeder}} \\ 9 \times I_{Norton_{300kVA_Xfr}} \\ 3 \times I_{Norton_{LVFeeder}} \\ 14 \times I_{Norton_{House\&Mains}} \\ I_{Norton_{House}} \end{pmatrix}$$

The model used for harmonic is inappropriate for fundamental frequency, therefore a type of fundamental frequency power-flow, suitable for a radial system has been implemented. A 1.02 p.u. voltage has been set for Islington 220 kV busbar, to allow for voltage drops. For incandescent lamps this gives a voltage profile for the busbars of: 1.0200, 1.0088, 1.0050, 0.9859, 0.9797, 0.9719, 0.9460 and 0.9457 p.u.

3. Summary of Results

Table 1 shows a summary of the main results from the simulations. The harmonic losses is the energy dissipated in the system due to the harmonic currents flowing in it. This must be weighted against the lower losses at 50 Hz due to the small current draw of the CFLs (90 mA to 150 mA) compared with 380mA to 435 mA for a typical equivalent incandescent lamp. The Voltage THD shows the maximum level experienced in the system. The main reason for the

losses being lower in the overhead line system compared to the cable is that the voltage level droops more and hence the load draws less power.

Table 2 shows the comparison between the CFL case and the base-case of using incandescent lamps i.e. $\text{Diff} = P_{\text{incandescent lamp}} - P_{\text{CFL}}$. Hence the harmonic losses are always negative as these are zero for incandescent lamp case and exist for CFL case. The use of CFLs clearly results in an improved system voltage for all cases. This is because the power-factor is leading. The losses for the overhead system is less primarily because the voltage drop is greater, hence the load power is smaller.

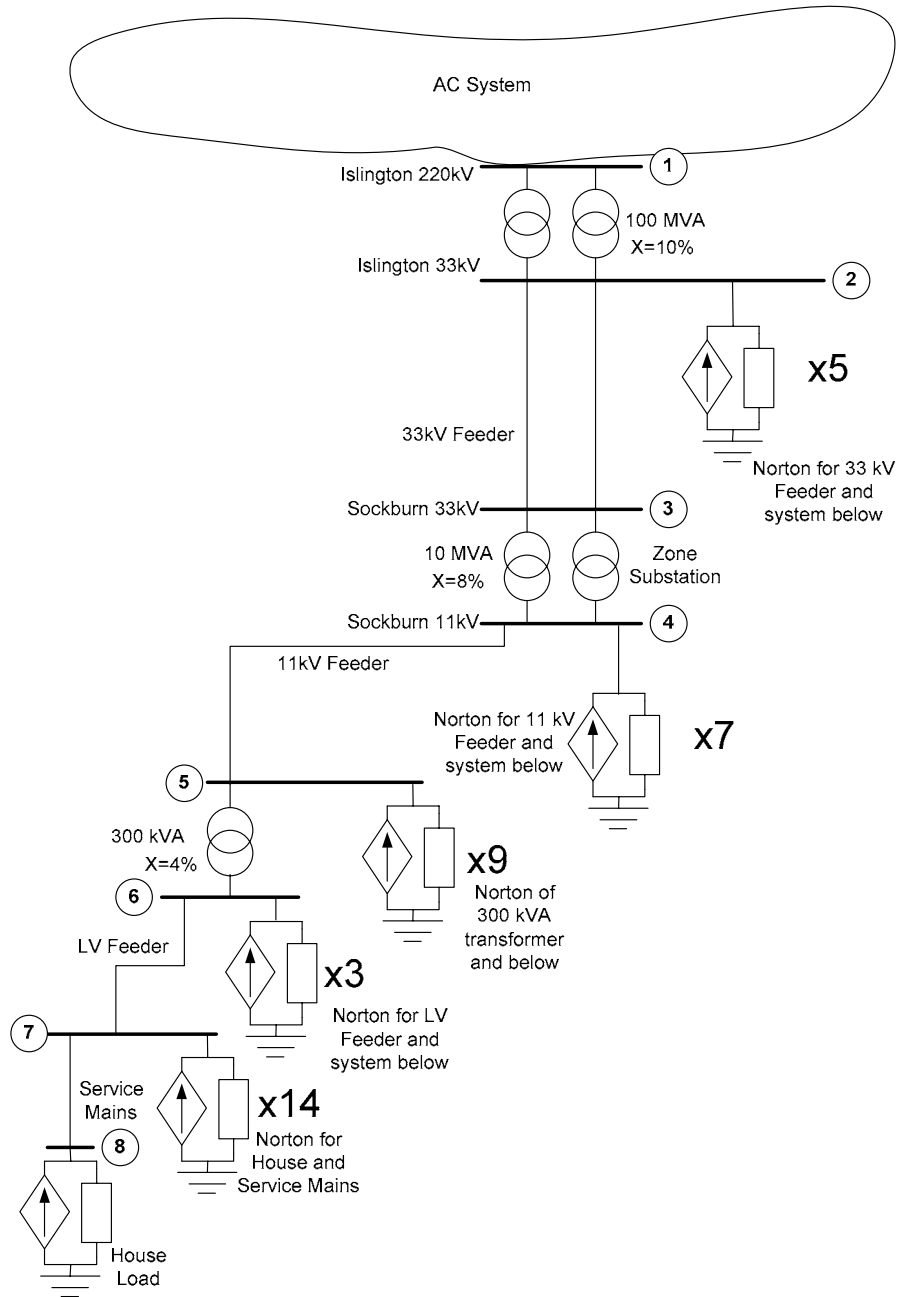

Figure 4. Complete Simulation Model

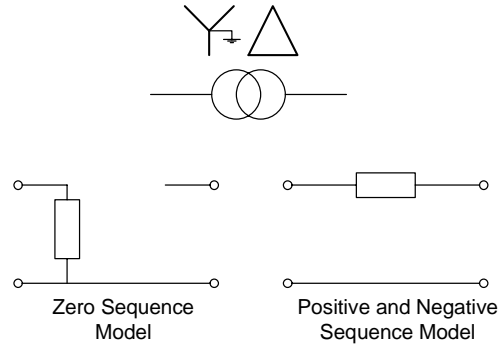

Figure 5. Effect of Transformer Winding Configuration

Figure 6 gives a breakdown of in what branches the harmonic and fundamental frequency losses are incurred. The key to Figure 6 is:

Branch No.	Description
9	House Loads
8	Service Mains
7	LV Feeders
6	300 kVA Transformers
5	11 kV Feeders
4	33/11 kV Transformers
3	33 kV Feeders
2	33/220 kV Transformers
1	220kV System

Most of harmonic losses occur in the household loads while the next highest occurs in the LV feeder, while most of the fundamental frequency losses occur in the LV Feeder (Figure 6(a)). The harmonics losses are broken down into their frequency components in Figure 7. This profile is a function of the CFL's characteristics and for this average CFL the 5th followed by 3rd then 7th are the frequencies contributing to the most harmonic losses.

Besides losses, power quality is an important aspect due to the repercussions of poor power quality. The Voltage THD (Total Harmonic Distortion) is an important index and a comparison of the Voltage THD is given in Figure 8. The regulatory limit for New Zealand is 5% Voltage THD.

Some old ripple control systems use the 21st harmonic, i.e. 1050 Hz, as the signaling frequency, hence the voltage at this frequency is given special attention. These level will be influenced by the system loading, with worst case being at night when the system is lightly load and the CFLs are in use. However this comparative study does indicates typical levels expected and hence the likelihood of interference with such systems (see Figure 9). It is clear that the CFL characteristics must be considerably better than the AS/NZS61000-3-2 if the desirable reference level of 0.08% is not to be exceeded. The 0.08% reference level was chosen to give a safety margin to allow for amplification due to local resonances and allowing for modelling uncertainties (variation in system conditions). An upper limit of 0.3% was provided by the ripple control manufacturer.

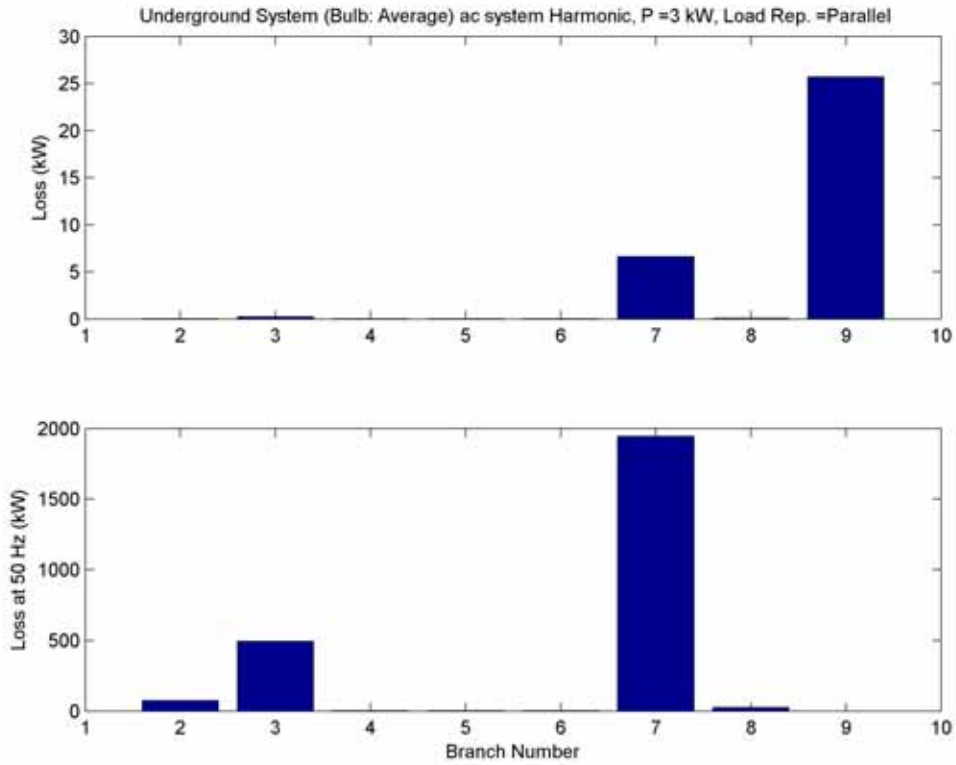

Figure 6. Breakdown of Losses into Branches

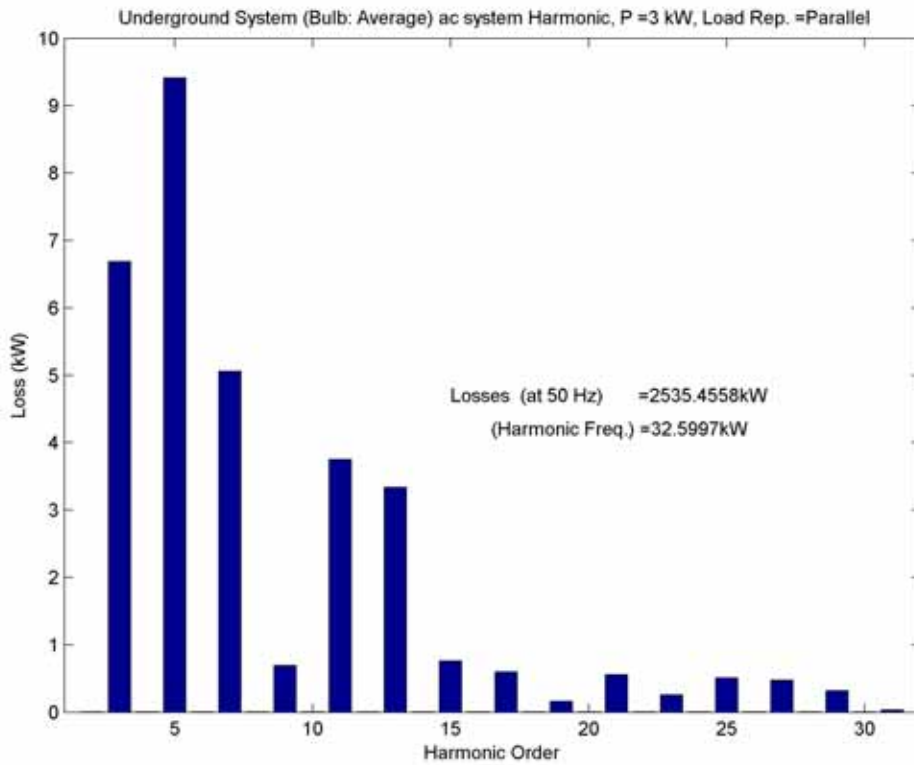

Figure 7. Breakdown of Harmonic Losses into Frequencies

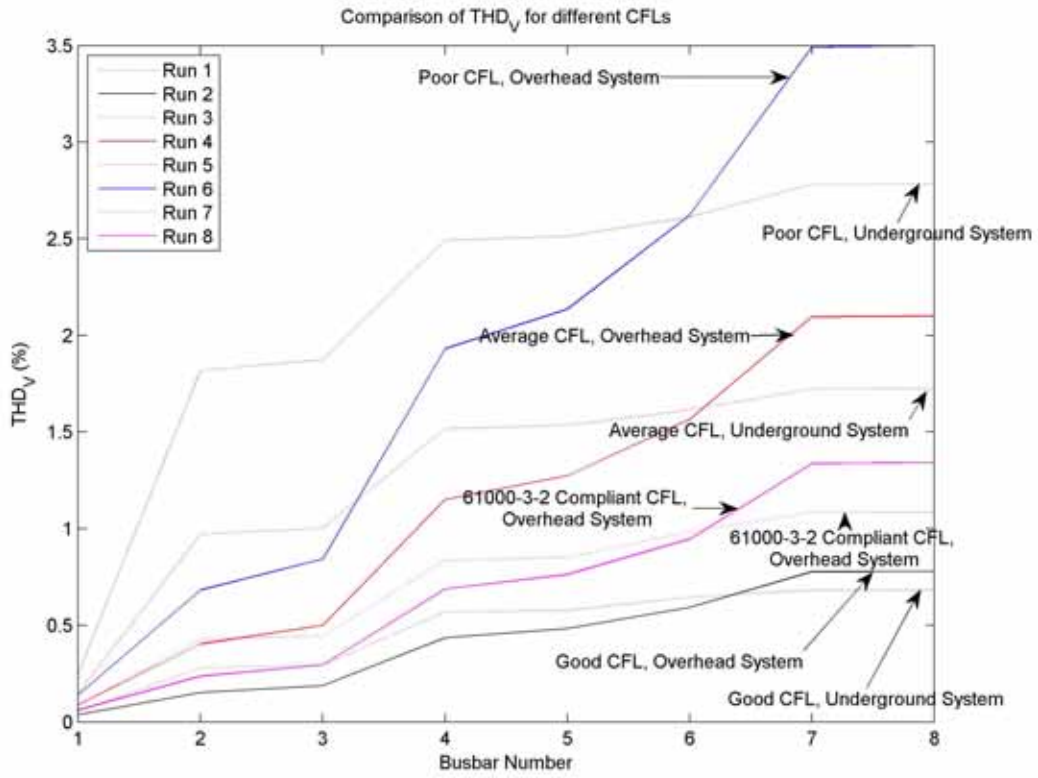

Figure 8. Total Harmonic Distortion of Voltage at Each Busbar

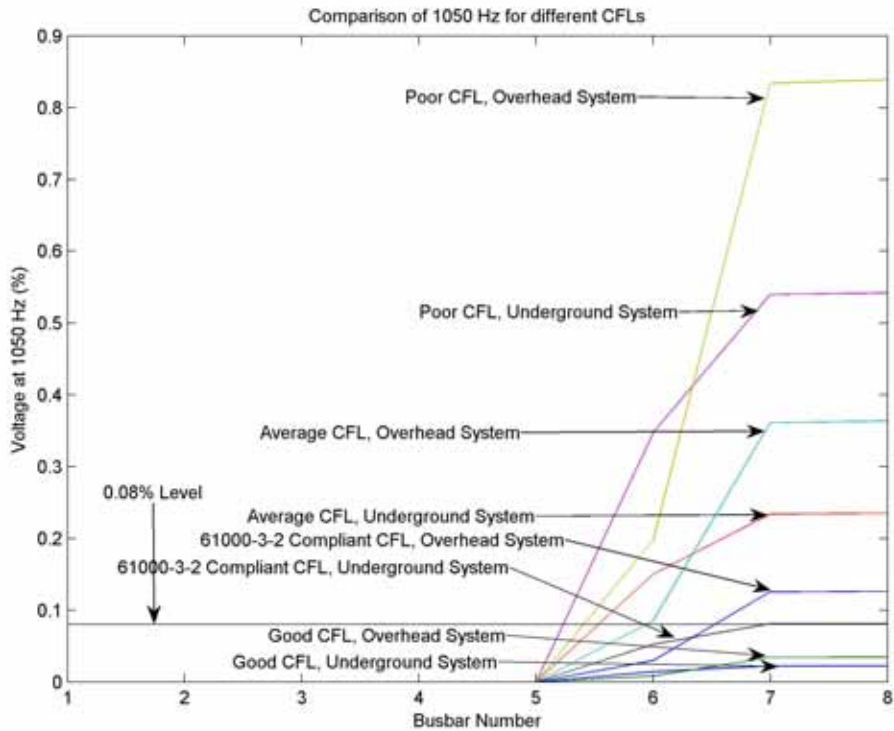

Figure 9. Magnitude of 1050 Hz at Each Busbar

4. Conclusions

Good CFLs are desirable because they do not cause as much degradation in power quality as the other, poorer CFLs bulbs do. Moreover they are less likely to cause malfunctioning of ripple control (using a frequency of 1050 Hz), or any other equipment sensitive to harmonic distortion, due to the lower injection at harmonic frequencies.

Good CFLs cannot be justified over poor CFLs purely on reduction in power consumption as the poor CFLs produce the same savings, and in some cases more. At fundamental frequency the good CFLs are almost resistive, hence combined with other loads (which are typically inductive) results in the total load being inductive. The poor CFLs are capacitive at fundamental frequency and hence inject reactive power that reduces the reactive power drawn over the network, which reduces line loss. This in some cases outweighs the extra losses due to the harmonics.

The poorer CFLs cause more harmonic losses. Moreover, they significantly increase the distortion levels at the higher voltage levels (clearly seen in Figure 6). This effect on the transmission level has the potential to adversely affect a large number of customers. The impact of harmonics flowing in electrical utility networks is diverse and often subtle. However reduction of equipment lifetime is not apparent and often erratic behaviour of equipment compels costly upgrade of production equipment without the real cause, voltage distortion, being identified. Therefore good CFLs should be installed as the effect of higher harmonic voltage levels will be detrimental to some equipment in the network, causing reduction in lifetime and, in some cases, destruction. Moreover some equipment, such as PLCs, are adversely affected by voltage distortion and will exhibit erratic behaviour (due to the time dependent nature of the harmonic distortion) or completely malfunction.

The mitigation of the harmonic distortion caused by CFLs is very difficult once in the network due to the dispersed nature. It is impractical to fit filters to all these dispersed sources once installed and installing system harmonic filters has its own issues, and ensuring good quality CFLs are deployed is better. Prevention is easier and cheaper than curing the problems after they occur. If the CFLs produce unacceptable harmonic distortion levels at a ripple frequency then filtering is not possible. This means that ensuring problems do not arise is very important as action after the event is not practical. The main way of achieving this is by ensuring the CFLs installed have the lowest level of harmonic injection that is practically possible at an acceptable price.

Table 1. Summary of Losses and THD (Voltage)

Run	CFL	System	Total System Power (kW)	Fundamental Power (kW)				Harmonic Losses (kW)	Total Losses (kW)	Max. THD voltage (%)
				Total	Load	Lighting	Losses			
1	Good	Under-ground	86047.206	86042.748	80784.626	2699.346	2558.78	4.458	2563.234	0.680
2	Good	Overhead	82678.245	82672.783	77501.610	2699.346	2471.827	5.461	2477.288	0.779
3	Average	Under-ground	85512.513	85479.913	80608.269	2336.188	2535.456	32.600	2568.055	1.724
4	Average	Overhead	82188.897	82147.623	77361.420	2336.188	2450.015	41.273	2491.289	2.101
5	Poor	Under-ground	85619.413	85541.228	80605.729	2395.026	2540.473	78.185	2618.658	2.784
6	Poor	Overhead	82308.713	82198.001	77348.337	2395.026	2454.639	110.712	2565.351	3.500
7	61000-3-2	Under-ground	86179.420	86163.725	80840.518	2761.480	2561.727	15.695	2577.422	1.263
8	61000-3-2	Overhead	82809.334	82791.301	77555.177	2761.480	2474.644	18.034	2492.678	1.341

Table 2. Difference with Incandescent Case

Run	CFL	System	Difference in Total System Power (kW)	Difference in Loss (kW)			Difference in Loading (kW)	V minimum (p.u.)	
				Total	50 Hz	Harmonic		CFL	Incandescent Lamp
1	Good	Under-ground	21911.720	630.219	634.677	-4.458	21281.500	0.952	0.946
2	Good	Overhead	21258.600	595.768	601.229	-5.461	20662.832	0.933	0.925
3	Average	Under-ground	22446.413	625.398	657.997	-32.600	21821.015	0.953	0.946
4	Average	Overhead	21747.948	581.767	623.041	-41.273	21166.181	0.934	0.925
5	Poor	Under-ground	22339.513	574.795	652.980	-78.185	21764.718	0.953	0.946
6	Poor	Overhead	21628.131	507.705	618.417	-110.712	21120.427	0.933	0.925
7	61000-3-2	Under-ground	21779.506	616.031	631.726	-15.695	21163.475	0.952	0.946
8	61000-3-2	Overhead	21127.510	580.378	598.411	-18.034	20547.132	0.933	0.925

Appendix A Extract from AS/NZS 61000-3-2

Active input power ≤ 25 W

Discharge lighting equipment having an active input power smaller than or equal to 25 W shall comply with one of the following two sets of requirements:

- the harmonic currents shall not exceed the power-related limits of Table 3, column 2, or:
- the third harmonic current, expressed as a percentage of the fundamental current, shall not exceed 86 % and the fifth shall not exceed 61 %; moreover, the waveform of the input current shall be such that it begins to flow before or at 60° , has its last peak (if there are several peaks per half period) before or at 65° and does not stop flowing before 90° , where the zero crossing of the fundamental supply voltage is assumed to be at 0° .

If the discharge lighting equipment has a built-in dimming device, measurement is made only in the full load condition.

Table 3. Limits for Class D equipment

Harmonic Order n	Maximum permissible harmonic current per watt (mA/W)	Limit based on 20 W (mA)	Maximum permissible harmonic current (A)
3	3.4	68	2.3
5	1.9	38	1.14
7	1.0	20	0.77
9	0.5	10	0.40
11	0.35	7	0.33
13 ≤ n ≤ 39 odd harmonic only	13	3.85/n	5.9
	15		5.1
	17		4.53
	19		4.05
	21		3.67
	23		3.35
	25		3.08
			See Standard