

## PERFORMANCE OF CEILINGS IN THE FEBRUARY 2011 CHRISTCHURCH EARTHQUAKE

Rajesh P. Dhakal<sup>1</sup>, Greg A. MacRae<sup>1</sup> and Keith Hogg<sup>2</sup>

### SUMMARY

This paper describes the performance of (or damage to) ceilings in buildings during the 22<sup>nd</sup> February 2011 Christchurch earthquake and the subsequent aftershocks. In buildings that suffered severe structural damage, ceilings and other non-structural components (rather expectedly) failed, but even in buildings with little damage to their structural systems, ceilings were found to be severely damaged. The extent of ceiling damage, where the ceilings were subject to severe shaking, depended on the type of the ceiling system, the size and weight of the ceilings and the interaction of ceilings with other elements. The varieties and extent of observed ceiling damage are discussed in this paper with the help of photographs taken after the earthquake.

### INTRODUCTION

A significant portion of the estimated 16 billion dollars loss incurred in the M6.3 22<sup>nd</sup> February 2011 Christchurch earthquake and the subsequent aftershocks can be attributed to non-structural components (also termed as secondary structural elements) and contents damage. This is in agreement with outcomes of previous seismic loss estimation studies [1, 2] which have shown that in buildings non-structural and content damage can contribute a major share of the total loss in an earthquake. As the demands from the induced ground motions were up to about twice of what tall buildings are currently designed for [3], expectedly several tall buildings suffered major structural and non-structural damage. Nevertheless, there were some low-medium rise buildings which suffered little/minor damage to their structural systems but severe damage to the non-structural components;

especially the suspended ceilings.

As shown in Figure 1, ceilings in New Zealand (NZ) may either be of direct fixed or suspended type [4]. Ceilings of low-rise residential buildings are commonly of the direct fixed type which comprise of gypsum plasterboards that are glued to light timber members. In case of commercial buildings though, the suspended type ceilings commonly consist of heavy infill panels (e.g., acoustic tiles) that are supported on a grid of steel beams. These are suspended through ceiling hangers anchored to the floor above. In NZ, while there is no restriction on the ceiling type that may be used in different situations, it has a strong correlation with the ceiling size. Commonly, small ceilings are of direct fixed type, whereas moderate and large ceilings more often have suspended cold-formed steel grid, on which the ceiling tiles sit.

While concealed ceiling grids with screw fixed plasterboard

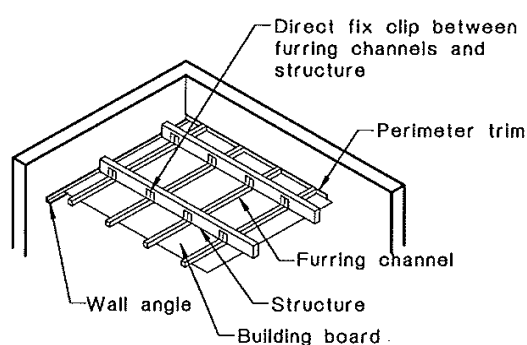

(a) Direct fix sheeted or flush system

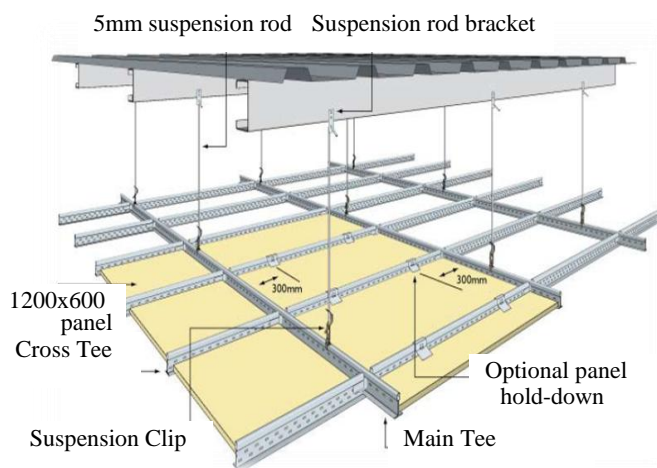

(b) Suspended system: Two-way exposed

Figure 1: Direct and suspended ceiling systems [4, 5].

<sup>1</sup> Associate Professor, Department of Civil & Natural Resources Engineering, University of Canterbury, Christchurch (Member)

<sup>2</sup> Manager, Director, Hush Interiors Ltd, Christchurch

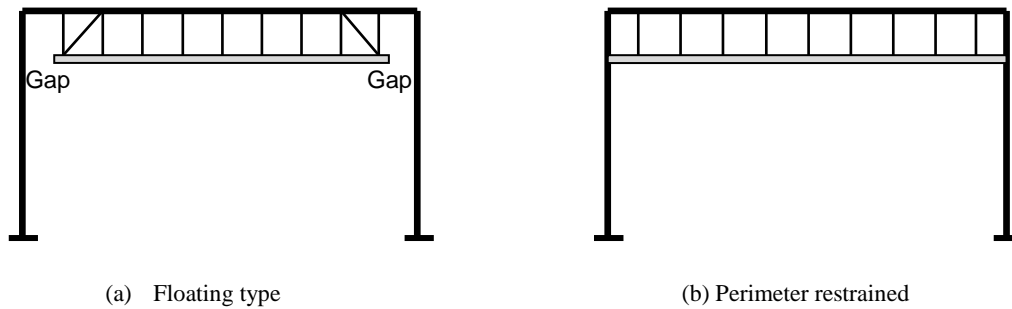

Figure 2: Common installation methods for suspended ceilings.

sheets (used in Japan) are available from some companies, they are not popular in NZ. The most popular systems are two-way exposed ceiling grids with drop-in tiles sitting on the flanges of inverted 'T' shaped members in the grid. One of these is shown in Figure 1(b). Here, the ceiling grid is suspended from the floor above using rods or wires. The tiles fit loosely in the grid so that they can easily be popped up for access to services. Here, these tiles may be punctuated by HVAC or fire sprinkler services. Also, in some cases the tiles are removed and replaced by fluorescent lighting.

A number of manufacturers in NZ (e.g. Rondo™, USG™ and Armstrong™) manufacture and supply the grids and the tiles for suspended ceilings. Many of these have used heavy tiles to limit sound transmissibility. Even modern buildings constructed in the last 10 years have ceiling tiles weighing 16 kg/m<sup>2</sup> or more. More recently, lighter tiles with the same acoustic rating have come out in the market, and with visibly less damage incurred by light-tiled ceilings in the recent earthquakes these light tiles are rapidly becoming popular.

Ceiling systems consist of the ceiling itself and all the components that may interact with the ceilings. Elements that may interact with the ceiling include vertical partitions, bulk heads, heating, ventilating and air conditioning (HVAC) equipment, electrical equipment, partitions, and fire sprinklers. A failure of one of these can result in damage to, and/or collapse of, part of a ceiling. Hence designing a ceiling system requires proper consideration of services, equipment and other interacting components in addition to the ceiling itself.

In NZ, there are two common installation methods for suspended ceilings: (a) Floating ceilings; and (b) Perimeter fixed ceilings. Floating ceilings are braced to the floor above to prevent large movements under service conditions, as well as to transfer horizontal earthquake induced inertia forces, and these are not connected to the perimeter wall/frame as shown in Figure 2(a). Here, the gap between the ceiling and the surrounding wall/frame has to be sufficient in order to eliminate the possibility of pounding damage during the expected excitation. On the other hand, ceilings that are restrained laterally by the walls/frames around their perimeter are called *perimeter fixed* ceilings. Small ceilings of this type do not normally use bracing; a schematic illustration is shown in Figure 2(b). Here, as the building moves laterally, the suspension clips and rods move on an angle to follow the deformation of the ceiling. Since the ceiling tiles do not sit tightly in the grid, the in-plane inertial force is not directly transferred from one tile to another; instead it is transferred through the grid. In this type, services connected to the ceiling, such as the HVAC and lighting fixtures, or fire sprinklers, may induce additional forces in the ceiling members. In NZ, most ceilings are perimeter restrained. In addition to the above two common types, discussion with the manufacturers have revealed that other types of ceiling installation, such as partially perimeter fixed ceilings (e.g., two sides of the ceiling fixed to the wall) and perimeter fixed ceilings having braced ceiling hangers, are also used; but not as frequently.

The recent Canterbury earthquakes have given valuable insight into the performance of ceilings being used in NZ. Damage to ceilings observed in the M7.1 Darfield earthquake on the 4<sup>th</sup> of September 2010 has been reported by the authors [6, 7]. It was found that the extent of ceiling damage varied greatly depending on the type of building and weight of ceiling tiles. In some cases, damage to ceiling systems caused major disruption; forcing the building/office to be closed for weeks despite only minor damage to the building's structural system. Many ceiling systems that had been re-installed following the damage in the September 2010 Darfield earthquake failed once again in a similar fashion during the February 2011 Christchurch earthquake. This paper reports some of the ceiling damage sustained in the M6.3 Christchurch earthquake on the 4<sup>th</sup> of February 2011.

## DAMAGE TO CEILINGS

Among the different non-structural building components, ceilings stand out as the most severely damaged component in the Christchurch earthquake. Commonly observed damage to different types of ceilings are described here with some typical damage photos taken after the earthquake in February. However, it is not to be misunderstood that the types of damage described herein occurred in all buildings. At this stage, it is not possible to provide a concise figure on percentage of buildings undergoing each type of damage described herein. More information should come to light as the insurance claim details come in. Since there is an excess in home insurance policies, damage of very trivial nature is unlikely to be reported. However, it was observed that most office/industrial buildings surveyed had substantial damage to their suspended ceilings whereas damage to plasterboard ceilings in single family dwellings was little. In general, two-thirds of office buildings in Christchurch visited by the authors after the earthquake had suffered non-trivial damage to suspended ceilings.

### Damage to Plasterboard Ceilings in Residential Buildings

Ceilings in residential buildings are typically small in size; which are made of plasterboards nailed and/or glued to timber studs. As shown in Figure 3, the damage to residential ceilings was related to the damage to the building's structural system. In residential buildings that had little structural damage, often ceilings also had little damage; mainly in the form of cracks on the plasterboard. However, there were cases, especially in the hill suburbs, where the ceiling diaphragm action was lost due to many cracks occurring in the ceiling. In structurally damaged buildings, ceilings and non-structural damage was often severe. For example, in the central city, most two-storey old unreinforced masonry (URM) buildings by the side of main streets had plasterboard ceilings. In most of these buildings, the front URM wall suffered out-of-plane collapse and the damaged ceilings were visible from the road. In some buildings, the ceiling was intact in one floor and severely



**Figure 3: Typical damage to residential plasterboard ceilings.**

damaged in the other. In other buildings where the side walls were also damaged, the ceilings had collapsed.

**Damage to Flush Type Gypsum Plasterboard Ceilings in Commercial Buildings**

Some multi-storey office buildings in the city were found to have flush type ceilings which had gypsum plasterboards glued and nailed underneath steel channels. This type of ceiling was found in two buildings the authors inspected in the city. As shown in Figure 4, these ceilings were found to have suffered damage of different extent. In a four storey building in Hereford Street which had significant but repairable structural damage, parts of the plasterboard had ripped off at different locations; mainly in the periphery of circular RC columns (see Figure 4 first row). This damage seemed to have been caused due to a combination of the column drift and movement of services above the ceiling, both of which applied extra force on the ceiling board. In another high-rise building (more than 10-storey) which also had significant structural damage, the flush type ceilings were found to have been damaged in the lower 3 floors (upper floors could not be

accessed due to safety concerns). In this building too, the ceiling damage was in the form of long/wide cracks leading to tearing of the board at some locations. The damage was found to be more around the edge/corner and less (almost none) towards the middle.

**COMMON FORMS OF DAMAGE TO SUSPENDED CEILINGS**

The majority of the medium-high rise office/commercial buildings inspected by the authors had suspended ceilings. The ceiling type, size and weight varied between different buildings; but most were of the perimeter fixed type. Common damage to these ceilings can be grouped into different categories as described below.

**Failure of Grid Members**

Observed damage to grid members and connections included detachment of the cross-tee from the main beam resulting in falling of tiles, failure of the main beam splice joint, breaking or buckling of main beams due to compression and torsion-



Damage to flush type ceiling in a four story building in Hereford Street



Damage to a plasterboard ceiling in a high rise office building in the city

**Figure 4: Damage observed in flush type ceilings in moderate-high rise commercial buildings.**



Failure of splice connection of the main beam

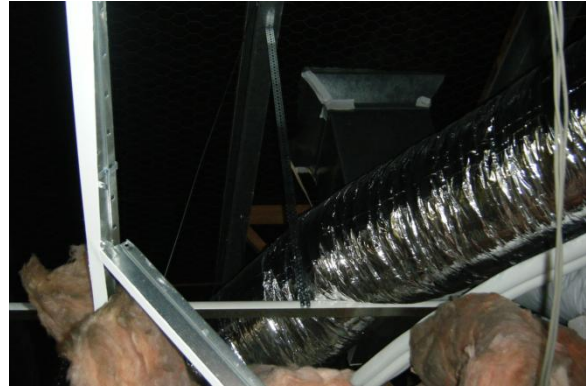

Failure of grid cross-member connection



Breaking, buckling and twisting of grid members due to large compression force



Damage to grid members due to excessive compression force (Photos: K Hogg)

**Figure 5: Collapse of suspended ceilings due to damage to grid members and connections.**

induced rotation of the joints. This was the most common form of damage observed in suspended ceilings. Several examples of observed grid failure are shown in Figure 5.

Grid damage results from excessive force on the grid members or connections. This then results in distortion of the ceiling grid under compression and subsequent buckling of the grid members or failure of the connections while the perimeter connections remained intact. Often, failure of one member or connection in a grid leads to a progressive failure of other members and connections; thereby resulting in a chaotic global collapse of the whole ceiling system. As tiles generally fall from the damaged grid, this type of damage poses a life-safety hazard. In some cases heavy tiles fell as far as 6 m onto the area below and it was fortunate that there was no injury or loss of life.

#### **Failure of Grid to Perimeter Angle Connections**

Perimeter damage results from the main or cross-tee losing seating on the perimeter angle around the ceiling. Loss of seating can result due to a lack of a rivet to connect the grid member to the angle or failure of the rivet itself. This results in the grid members and tiles dropping from the ceiling. The

hanging wires around the perimeter edge can prevent the member and tiles from falling in some cases, however this can result in the tile and members being forced back into the perimeter angle causing damage to the tiles and members. This results in localised damage around the perimeter of the ceiling. In some ceilings, the middle part was found to be intact and only the peripheral layer of the grid was found to be damaged; leading to dislocation of tiles (in some cases the tiles fell). Some typical perimeter connection damage are shown in Figure 6.

In most cases, the cause of perimeter damage was inadequate performance of the rivets used to connect the grid members to the wall angle. Common current practice is to connect the grid members to the perimeter angle with centre single size riveting which only connects to the face cap. As shown in the first two photos in Figure 7, such a riveting system was found to be inadequate. In some cases, the inadequate rivets were observed to fail in tension, leaving only the aluminium cap to hold the system together. In other cases, the rivets were also found to have ripped through the steel wall angles and tee rails. Detail specification on the number, size and location of the rivets for such perimeter connections are currently missing from the standards. In one case, during repair after the Christchurch earthquake in February, the end tee connections were provided



**Figure 6:** Localised ceiling damage due to failure of the grid members to wall angle connection.

with two rivets of bigger diameter. This detail survived the significant shaking during the  $M_w$  6.1 June 13 earthquake and the aftershocks afterwards. Only the trim suffered a small amount of distortion. A photo of this connection is shown in Figure 7 (right).

#### Ceiling Damage Caused by Services

Damage to suspended ceilings can also result from the force transferred from services above the ceiling into the ceiling itself. In the majority of the damaged suspended ceilings, the observed damage could be attributed to the extra force generated by the movement of services and equipment above the ceiling. In a standard installation of a suspended ceiling, the hanger wires are placed at 1200 mm centres. However, the presence of services (such as HVAC) above the ceiling can mean this is not possible. As a result suspended ceiling are sometime partially hung from services within the ceiling (most commonly HVAC ducting and plant). As such ducts and plant are rarely secured properly and when they move a force is imparted into the ceiling causing damage. Additionally, services above the ceiling moving during an earthquake can impact the hanging wire of the suspended ceiling, which will again impart force into the ceiling. Suspended ceilings are not designed to take the additional force from such interactions. Grills within the ceiling plane were often observed to have

fallen from the ceiling and localised loss of tiles often occurred around the location of these grills. Some instances of ceiling failures resulting from the interaction with the services and equipment are shown in Figure 8.

In some cases, the ducting volumes make it difficult for bridging and fixing of sprinkler ducts and in some buildings, the service height provided was found to be too small with no room for proper bridging under services. The right photo in the first row in Figure 8 shows a case like this. In one ceiling, a ceiling tile was broken due to a rigid sprinkler with an inadequate gap pushing the tile. It was felt that if a sufficient gap was provided around the sprinklers and any service and equipment were properly secured independent of the ceilings, the damage to suspended ceilings could have been greatly reduced.

#### OTHER TYPES OF DAMAGE TO SUSPENDED CEILINGS

Apart from the common forms of damage described above, the authors also observed some other types of damage to suspended ceilings. These were not very common, but were observed in some buildings. They are summarised below.

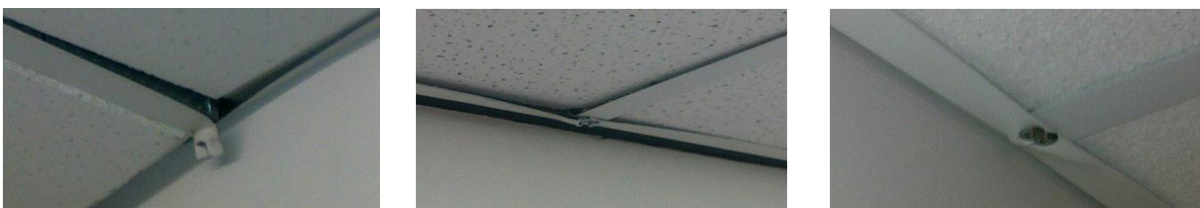

Damage caused by failure of the main beam/cross-tee to wall angle rivet

Perimeter connection with increased number and diameter of rivets

**Figure 7:** Effect of rivet number and diameter on the performance of the perimeter connections.



Ceiling damage caused by unbraced AC ducts



Damaged ceiling with inadequate service height



Localised damage to ceiling grid and tile due to interaction with sprinkler



Interaction with service

**Figure 8:** Typical damage to suspended ceilings caused by movement of service/equipment above.

**Dislocation of Tiles**

Typically the ceiling tiles sit on the flange of inverted T-beams of the grid without any fastening. No clips are used to hold the tiles in place, which implicitly assumes that the weight of the tiles is enough to keep them on the beam flanges. However, large vertical accelerations (as high as 2.2g) were recorded in some stations in and around Christchurch. When the tiles are subjected to vertical acceleration in excess of 1g, they will jump up, and when they come down they may not sit exactly inside the same grid. Vertical movement of ceilings may also have resulted from vertical deformations or rocking of some structural systems. As a result, it is not surprising to see some tiles dislodged from their original positions, and some fallen ceiling tiles possibly resulting from the vertical acceleration effect. In one case, the grid members

were intact in the shape of a rectangle but the tile was missing. In another case, the impact from the jumping tile seemed to have broken the flange of the grid member; resulting in skewed and tilted ceiling tiles (see Figure 9). The consequences of damage possibly caused by vertical shaking were not as severe as that caused by horizontal shaking.

**Damage due to Interaction with other Non-Structural Components**

Damage to suspended ceilings can also result from elements that are connected to the ceiling but which should be independent. Common examples of this are timber or steel framed bulkheads and partitions. Partitions in particular should not rely on lateral support from the suspended ceiling unless it is specifically designed this way. Partitions



Dislocation of ceiling tile due to vertical acceleration



Damage to flange of the grid beam due to tile impact

**Figure 9:** Minor damage to suspended ceilings possibly due to vertical movement of the tiles.



Damage to ceiling and bulkhead

Bracing of partition wall can damage the nearby hangers during movement

Damage to glazed partition: glass panel detached from the top track

**Figure 10: Ceilings and other components likely to be damaged due to mutual interaction.**

constructed this way can apply extra force into the ceiling during an earthquake; thereby damaging the ceiling. In some cases, the observed damage could be attributed to the interaction between ceilings and bulkheads. Bulkheads hanging from tiled ceilings dropped when the ceiling perimeter connection failed, as shown in Figure 10 left. In one building it was found that during renovation, bulkheads were removed but no bracing was put in place to take the ceiling load.

Interaction with partition walls also caused damage to some ceilings braced to the walls. Some internal walls extend to the floor above and are supported either directly by the floor or a beam through inclined braces. In some cases, the ceiling may also be supported on these internal walls. The braces of these walls are close to the ceiling hangers and other equipment braces and are likely to interact with the system. It was found that the failure of the braces (some of which fell off) could easily have caused significant damage to the ceilings (see Fig 10 centre). In some cases, the partition walls stop at the ceiling level and are braced by ceilings. Obviously, in such cases the ceiling needs to cater for the wall as well. Any change to these partitions during renovation can increase the ceiling loads. Glazed partitions fall into this category, and due to small aluminum sections they are difficult to brace. In some buildings, such wall partitions were found to be out of plumb and in glazed partitions the glass jumped out of the top track (see Fig 10 right).

### Grid Spreading

The suspended ceilings discussed in the previous sections are all two-way exposed grid systems; i.e. they consist of a two-way grid of inverted 'T' shaped members hung from the ceiling above. The tiles are then dropped in and rest on the flange of the inverted 'T' sections. There are a few suspended ceilings that have grids that are different to the two-way type grid. These older grids consist of main beams spanning one way and hung from the floor or roof above. There are typically no transverse runners (except where the ceiling may have been retrofitted with these). The drop-in tiles prevent the grids from spreading apart during an earthquake. However, if a tile drops out there are no members to stop the grids moving apart (spreading) and causing further tiles to fall from the ceiling; thereby leading to a progressive failure and global collapse of the whole ceiling. Also, as opposed to the two-way grid ceiling systems, the tiles are not supported on all four edges in a one-way grid. The tiles are instead interlocked, so when one tile falls it leaves the next tile susceptible to falling.

Damage related to grid spreading in one-way grid ceilings have been reported in Darfield earthquake [7]; and although the authors did not get first hand opportunity to visit buildings with one-way ceiling grids, they have heard that grid spreading did occur in some buildings in the Christchurch earthquake as well.

### EFFECT OF CEILING SIZE AND TILE WEIGHT

The uniformly distributed mass (in the form of tiles) in a ceiling generates uniformly distributed inertial force, which induces axial compression in the grid members and connections. This force accumulates and becomes greater near the support (i.e. the perimeter) than in the middle [8]. This indicates that the maximum force acting on the grid members and connections near the perimeter is proportional to the size of the unsupported length of the ceiling and the weight of the ceiling tiles. While ceilings with an area greater than a specific value require braces, these can also impose displacement compatibility demands in fixed perimeter systems and the possibility of damage. In general, a combination of smaller ceiling and lighter tiles result in lower demand on the grid members and connections, which leads to safer ceiling. This is also supported by the performance of ceilings observed in the Darfield and Christchurch earthquakes. The undamaged ceilings generally were either very small and/or used light-weight tiles, which ensured that the grid members and connections were exposed to small forces. Even in damaged ceilings, the observed compression damage of grid members and connections was more severe near the perimeter, and visibly less damage of this nature was seen around the centre of the ceilings. As shown in Fig 11 (first row), failure of the grid members typically started at the end block near the wall, which indicates that maximum force is induced there. This also means that had the size been smaller, the forces in the grid members and connections would be smaller than their capacity; that is why size of the ceiling matters.

Figure 11 shows the different extent of damage observed in ceilings of different size. The second row in the figure shows damage to ceilings (using heavy tiles) in two rooms of the same building (in the corner of Colombo Street and Peterborough Street). The one on left is the ceiling in a smaller room; whereas the right photo is of the ceiling in a bigger room (7 m × 12 m). As can be seen, the damage to the smaller ceiling is trivial; and this may have been caused by the interaction with the service pipe and not due to the excessive axial force; because the grid members are intact in the perimeter and a service pipe seems to have pushed the dropped tile. On the other hand, the damage suffered by the



Typical grid failure at the end span near the wall due to accumulated force



Damage incurred to a small ceiling



Damage to a large (7m x 12m) ceiling

*Figure 11: Effect of ceiling size on the extent of damage.*

ceiling in the bigger room is visibly more severe with failed grid members and connections in the perimeter and a large number of tiles fallen down. This strongly indicates that the size of the ceiling has a significant effect on the extent of damage.

The preceding discussions also indicate that for a ceiling of a given size, the tile weight dictates the compression force induced in the grid members and connections. In other words, a ceiling grid with heavier tiles will be subjected to larger axial force; thereby making it more likely to damage/fail. Again, this is supported by the ceiling performance observed in the Christchurch earthquake. Some evidences to support this statement are shown in Figure 12. In the first row, two different types of ceiling in a two-storey building (in Colombo Street) are shown. The left photo is of a ceiling in the second storey which had heavier tiles and the right one is from the same building, but in the lower storey and using lighter tiles. As can be seen, the heavy-tiled ceiling has completely collapsed whereas the ceiling with lighter tiles is perfectly intact. The size of the two ceilings (i.e. rooms) was comparable. Note that the heavier ceiling was in the upper floor, and could have been subjected to larger floor accelerations; but even then the difference in the extent of damage of the two ceilings is too much to be attributed to the slightly different acceleration demand.

The second row of Figure 12 shows two ceilings which were reasonably large (one was 15 m long) but still remained intact after the earthquake. The left one is from a single storey lecture theatre in the University of Canterbury and the right one is from the ground floor of a two-storey commercial building in Tuam Street. Both of these ceilings used light-weight tiles. All heavy tiled ceilings of comparable size the authors visited were severely damaged. These observations further support the argument that the weight of the tiles has significant effect on the damage of suspended ceilings.

#### IMPORTANCE OF DOING THINGS CORRECTLY

The causes of observed ceiling damage can be broadly divided into two categories. The first category includes the deficiencies that resulted because of the unexpectedly high demand (the ground motions were significantly greater than what designers currently consider in designing buildings and parts including ceiling systems) and our lack of understanding of the ceiling capacity (strength, arrangement and detailing of the grid and perimeter connections). In such cases, the observed damages provide a valuable opportunity for us to learn and improve our practice in future. On the other hand, the second category of deficiency results from doing things wrongly despite knowing how they should be done. Frustratingly, a significant proportion of the observed damage resulted from carelessness and there is no lesson to be learnt from this damage.

Currently, there are standards which provide design and installation guidelines for ceilings and services, equipment and other non-structural components interacting with ceilings. Nevertheless, these recommendations are not mandatory; so designers, builders and installers are not required to strictly follow these guidelines. The authors felt that in many cases the extent of ceiling damage would be significantly less if the things we already know had been implemented properly. It is well known and universally accepted that: ceilings should be braced properly (either to the wall or to the floor above); rigid sprinklers should have an adequate gap with the ceiling tiles; ceiling hangers should be spaced adequately; heavy components and service equipment should be braced to the floor independent to the ceiling, etc. Yet there were many buildings where these commonsense measures were found to be blatantly violated. Where these commonsense measures were properly applied, the damage was limited. Ceiling damage observed in such properly constructed ceiling systems





Ceiling damage in the upper floor with heavy tiles



Undamaged light tile ceiling in the lower floor



Rare cases of large suspended ceilings with little or no damage (both had light tiles)

**Figure 12: Effect of tile weight on the extent of ceiling damage.**

was mainly due to gap in our knowledge and this damage taught us lessons for the future. Some cases of good practice, where these measures were found to be followed properly, are shown in Figure 13.

Instances of unsecured services, improperly braced components, insufficient gap around sprinklers, inadequate gap above the ceiling, partition braces flirting with ceiling hangers etc could be noticed in a number of ceiling damage photographs provided in the previous sections. Some additional examples of such poor practices are shown in Figure 14. As can be seen in the photos, it is not uncommon to see the HVAC and other service pipes resting directly on the ceiling without any bracing from the floor above. Similarly, in

another example shown below, a damaged ceiling is being fully replaced with a seismically designed ceiling after the Christchurch earthquake, but the partition contractor braced the glazed wall to the A/C unit.

Similarly, when bulkheads and partition walls are braced to the ceiling, this requires appropriate ceiling design. In many cases, simple ceiling considerations for the structural elements at the design stage may result in the ceiling not requiring any bracing. The authors found several anecdotal references to partition walls being added/removed/alterd without any consideration to the ceiling which is connected to the wall and will inevitably be affected by the alteration.



Rigid sprinkler with sufficient gap: no extra damage due to ceiling-sprinkler interaction

Services braced independent to the ceiling →



**Figure 13: Examples of good practice.**



HVAC pipe supported by ceiling grid      Glazed wall braced to AC unit      Unbraced AC ducts resting on the ceiling

*Figure 14: Examples of malpractices in installation of components and services interacting with ceilings.*

### PERFORMANCE OF REPLACED CEILINGS

Many ceilings that had collapsed during the February 2011 Christchurch earthquake were repaired/reinstalled after the September 2010 Darfield earthquake. Sometimes they were reinstalled in the same way as before the Darfield event, sometimes some modifications were made to the pre-existing ceiling, and in other cases the ceilings were replaced. In this section, we describe the behaviour of a few ceilings that had been reinstalled in different ways after experiencing extensive damage due to the September earthquake. The buildings described were not in the central city and experienced shaking similar to the design level.

In a three-storey building, the ceilings at the different levels were treated in different ways. At the top level, the grids were tied together with horizontal cross rails over the whole width of the floor. The cross rails were not a proprietary or tested system. These rails were connected to the wall at either end with angle brackets. This method seemed to work very well in general, with not many tiles falling. The tiles which did fall extensively were around the perimeter of the ceiling. This is because the movement in the perimeter, which was permitted by the deformability of the angle brackets, was more than the seating provided by the perimeter wall angle. In the ground floor, the whole ceiling system was replaced with a brand new system with light-weight tiles. In general, this performed very well. However, the ceiling continued between two buildings, and where one building moved relative to the other, the tiles and the grid damaged and collapsed near the ground floor columns.

A five-storey office building had small cantilevered rooms at the south end. In a meeting room in the 5<sup>th</sup> storey (of area about 100 m<sup>2</sup>), the two way ceiling grid was replaced after extensive failure in the September earthquake and heavy tiles (similar to those used before) were laid. However, during the February earthquake, total collapse of the tiles occurred again and the grid was severely damaged. The only tiles that did not hit the ground were those connected by lighting or fire cords.

A major theatre-like room with heavy tiles in a sloping ceiling had about one half of the heavy tiles collapse in the September earthquake, with some falling up to 5 m. Because of the slope of the ceiling, once a tile was dislodged, there was no resistance for the other tiles. No extra restraint was provided to the linear air conditioning units going across the room in the ceiling space. The room was closed for more than a week while the heavy tiles were reinstalled using the same system that was used in the building described in the previous paragraph. During the February earthquake, about one quarter of the tiles collapsed again.

Since February 2011, many different design solutions have been implemented including the use of full bracing, sliding, and other techniques. A number of ceilings with areas greater

than 2000 m<sup>2</sup> have been designed and installed with floating and braced ceilings. For cases where a proper design was completed at an early stage, ceiling installation has been efficient. However, when ceilings are installed without following a proper design, the ceilings may be damaged again in future earthquakes; thereby resulting in a significant waste of resources.

### CONCLUSIONS

Damage to ceilings and other components (including services and equipment) interacting with ceilings observed in the February 2011 Christchurch earthquake has been reported in this paper. The observed damage to ceiling systems could be attributed to a number of factors including inadequate strength of grid members and connections, large size and weight of ceilings, interaction between ceilings and other elements, inadequate independent securing of services and equipment, and in some cases excessive vertical accelerations. In some commercial buildings, there were cases where the extent of ceiling damage was more severe than the damage to the structural system. The observed ceiling damage exposed several weaknesses in our existing design and installation practices for ceilings and interacting elements. Some of the lessons learnt are:

- The maximum force induced in the grid members and connections of perimeter fixed suspended ceiling systems increases with the size of ceiling. This has been found by research [8] and supported by the observation as the observed grid compression failure was mostly closer to the perimeter than in the middle.
- Ceilings with heavier tiles/panels were observed to undergo severe damage, whereas little damage was observed in ceilings (despite large size) that used lighter tiles. Hence, wherever feasible use of heavier tiles should be avoided in ceilings.
- The observed damage in ceilings was very severe in many cases and it was only a coincidence that nobody was killed due to ceiling failure in these earthquakes. As the 2011 Japan earthquake has proved, heavy ceiling tiles falling from several meters can easily be fatal. Even in rooms without heavy tiles, cross members bent down like skewers, causing a major hazard for anyone exiting the building. Hence, ceilings should be designed for life safety (i.e. ultimate limit state) rather than for serviceability.
- Interactions with services and equipment above the ceilings, partition walls and bulkheads were found to be the cause of several ceiling failures. Hence, the requirement to restrain services above the ceilings should be strictly complied with. Similarly, improved design

guidelines for ceilings systems, taking into account the interactions with partition walls, are needed.

- More than weaknesses in design, the cause for poor ceiling performance (in comparison with structural performance of buildings) seems to be poor installation practice of ceilings, services and partitions (i.e. not adhering to the guidelines). Hence, quality control measures should be put in place to ensure compliance.
- There is a tendency for ceilings to be replaced fast after an earthquake. However, unless this is done properly, further damage and collapse can occur in aftershocks and future earthquakes.

#### REFERENCES

1. Taghavi, S. and Miranda, E. (2003) *Response Assessment of Non-structural Building Elements*. Report No. 2003/05. Pacific Earthquake Engineering Research Center, Richmond, CA.
2. Bradley, B.A., Dhakal, R.P., Cubrinovski, M. and MacRae G.A. (2009) "Seismic loss estimation for efficient decision making". *Bulletin of the New Zealand Society of Earthquake Engineering*, Vol. **42**, No. 2, pp. 96-110.
3. Carr, A.J. (2011) *Inelastic Response Spectra for the Christchurch Earthquake Records*. Report to the Canterbury Earthquakes Royal Commission, 98 pages, <http://canterbury.royalcommission.govt.nz/Technical-Reports> (assessed 22 September 2011).
4. AS/NZS 2785 (2000) *Suspended Ceiling – Design and Installation*. *Standards New Zealand*, Wellington.
5. Rondo Key-Lock (2009) *Concealed Suspended Ceiling Systems*, Auckland, New Zealand.
6. Dhakal, R.P. (2010) "Damage to Non-Structural Components and Contents in 2010 Darfield Earthquake". *Bulletin of the New Zealand Society of Earthquake Engineering*, Vol. **43**, No. 4, pp. 404-411.
7. MacRae, G.A., Hair, J. and Dhakal, R.P. (2011). "Ceiling damage in the 2010 Canterbury earthquake". *Eighth International Conference on Urban Earthquake Engineering (8CUEE)*, 6-7 March, Tokyo, 5 pages.
8. Paganotti, G., MacRae, G.A. and Dhakal, R.P. (2011). "Development of typical NZ ceiling system seismic fragilities". *Ninth Pacific Conference on Earthquake Engineering (PCEE)*, 14-16 April, Auckland, 8 pages.