

ANALYSIS OF HOLLOWCORE CONCRETE FLOOR SLABS UNDER FIRE

JEREMY CHANG¹, ANDREW H. BUCHANAN², RAJESH DHAKAL³ and PETER J.
MOSS⁴

ABSTRACT

The aim of this paper is to provide recommendations to designers, and to propose a simple method for designers to model the structural behaviour of hollowcore concrete floor slabs in fire. The proposed finite-element model incorporates a grillage system using beam elements to capture the thermal expansion of the precast units in both directions, with the topping concrete over several precast units modelled by shell elements. The research reported herein compares the proposed model with various fire test results of hollowcore concrete slabs. The simulation outcomes show good agreement with the experimental results.

Several hollowcore concrete slab flooring systems tested previously at the University of Canterbury for seismic purposes were simulated using this modelling scheme. Various supporting schemes have been considered, and the results show that different arrangements of axial and rotational restraint at the supports can significantly influence the fire performance of the concrete slab floors.

¹ PhD candidate, University of Canterbury, Department of Civil Engineering, Private Bag 4800, Christchurch, New Zealand, email: clc45@student.canterbury.ac.nz

² Professor, University of Canterbury, Department of Civil Engineering, Private Bag 4800, Christchurch, New Zealand, email: andy.buchanan@canterbury.ac.nz

³ Senior Lecturer, University of Canterbury, Department of Civil Engineering, Private Bag 4800, Christchurch, New Zealand, email: rajesh.dhakal@canterbury.ac.nz

⁴ Associate Professor, University of Canterbury, Department of Civil Engineering, Private Bag 4800, Christchurch, New Zealand, email: peter.moss@canterbury.ac.nz

1. INTRODUCTION

Precast prestressed hollowcore concrete (HC) floor systems have become very common in New Zealand and in many other countries. HC floor systems consist of several HC slabs with or without a layer of reinforced concrete (RC) topping. The benefits of using HC floor system are the low onsite labour cost, low self-weight, consistent quality, and economical use of concrete.

The structural behaviour of a HC floor system under fire is complicated, and precise computer models for simulating the structural behaviour of HC slabs under fires have been developed to improve the understanding of this behaviour¹. There are many existing studies investigating this behaviour with different approaches^{1,2,3,4,5,6,7}. However, very detailed finite element analyses for modelling the structural fire behaviour of HC slabs are too time-consuming to apply in the day-to-day design process. At the other end of the spectrum, simplistic approaches using a simple code rules are insufficient to capture the thermal expansion across the units or the effects of the support conditions. This paper aims to propose a simple yet sufficiently accurate method for designers to model the structural fire behaviour of HC slabs, and then based on the simulation results to provide some recommendations on the fire design of HC floor systems.

2. BACKGROUND

It is widely recognised that the behaviour of HC slabs under fire is more complicated than that of solid slabs. The cavities at the centre of the slabs cause discontinuity of the thermal transfer, and the thermal gradient needs to be addressed correctly to accurately model the temperature induced mechanical strains in the webs². The support conditions also have significant influence on the structural behaviour of floors⁸, this is especially so in HC floor system^{1,2,9}, and the effect of the support conditions should be considered in design. The presence of prestressing stress has been proven to also considerably influence the predicted overall structural performance¹⁰ as the HC units have no reinforcing and the resistance to tensile stresses comes from the prestressing tendons. Therefore, the fire design of the HC floor system needs to be able to accommodate different support conditions in different buildings, and the designers must recognise the fact that prestressed structural members demonstrate different behaviour to ordinary members.

There are three design methods for concrete members outlined in the Eurocode 2¹¹, namely tabulated data, simple calculation methods and advanced calculation methods. The tabulated data from the Eurocode 2, or the NZ Concrete Structures Standard NZS3101¹², do not consider the unique thermal gradient of the HC slabs nor does it take into account the influence of the surrounding structural members. Simple calculation methods cannot

accurately predict the thermal gradient, or include the effect of support conditions. Due to the rapid development in computation in recent years with advanced modelling methods, commercial finite element analysis [FEA] programs could be used to design HC floor systems based on the fundamental physical behaviour with due consideration to the effects from the surrounding structure. This fits into the category of “advanced calculation methods”.

This research uses the commercially available non-linear FEA program SAFIR¹³. The program was developed for analysing steel or composite structures, but the shell element in SAFIR has been proven to also accurately predict the fire behaviour of RC slabs¹⁴. A previous study showed that SAFIR can successfully predict the structural behaviour of *hibond* slabs (proprietary composite slabs) using a combination of shell and beam elements¹⁵, which is the basic idea behind the proposed model in this study.

The grillage analogy has been used for a long time and proved to be reliably accurate in bridge designs¹⁶. Grillages by definition have straight longitudinal and transverse beams rigidly connected together, each beam with its bending and torsional stiffness, and at each junction the deflection and slope is calculated^{17,18}. This grillage analogy became the alternative option.

Previous study has demonstrated that two-way supported RC slabs have better fire resistance than one-way supported slabs due to the membrane action¹⁴. Besides, restraint due to the surrounding structure has been proven to have a favourable effect on the performance of HC floor system in fire. After introducing the new model, this research uses it to explore the possibility of increasing fire resistance in the HC floor systems through membrane action.

3. MODEL DESCRIPTION

The aim of this model is to simulate the behaviour of the entire floor system including the surrounding structural members such as columns and beams. Detailed descriptions are shown in elsewhere¹⁹, but a summary of the key features is reported here. The final proposed model as shown in Fig. 1 uses beam grillages for the HC units, and shell elements to model the topping RC slab. Shell elements in SAFIR require less discretisation and are suitable for large displacements, but the thermal gradient is one directional and perpendicular to the element. Beam elements are more complex, requiring more computational effort, but can capture the thermal gradient more accurately and allow for prestressing.

The grillage system allows the model to capture the thermal expansion in both lateral directions, so that the effects of the restraints on lateral displacements from the surrounding structure can be well captured. In the grillage, all degrees of freedom except warping of the longitudinal and transverse beams are shared at the intersection points. The topping is modelled using shell elements which join the grillage system at these points and share these degrees of freedom. The longitudinal beams are used to address the thermal gradient around

the voids correctly and include the effect of the prestressing tendons. This prestress effect is accounted for when the stress equilibrium in the cross-section is calculated at the first time step. The transverse beams comprise only the top and bottom flanges and span only within the width of each HC unit, thus accounting for the thermal expansion of each unit in the lateral direction, which may affect the structural behaviour of the HC floor system especially when there are restraints on the sides. Therefore, the effects of the restraints on lateral displacements from the surrounding structure can be included. Examples of the thermal gradients in a longitudinal and transverse beam are shown in Fig.2 (a).

Some details need to be overlooked to reduce the complexity of the model. Shear and anchorage failures as well as bond failures are not considered in this model due to the complexity and the computational effort needed when simulating the entire structure. Spalling may cause problem as observed in experiments before¹⁴ but is not considered here, as the possibility of spalling depends on the curing period and the age of the building, and introducing these factors would make the results specific and not representative. Currently, no FEA program incorporates this effect on account of the uncertainties and lack of specific experimental data.²⁰

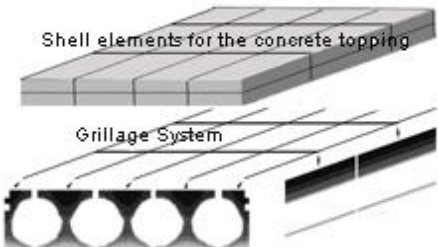

Fig. 1 – Schematic drawing for modelling of HC floor system

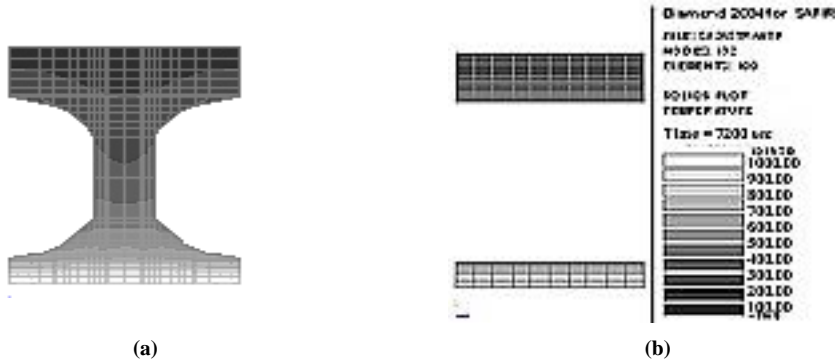

Fig. 2. – Temperature distribution of SP265 Ergon after 2hr. of ISO fire from (a) longitudinal beam (b) transverse beam

4. MODEL VALIDATION

This section shows the comparison between the test data carried out by various institutes and the simulation results.

4.1. Universities of Ghent and Liège

Four tests were carried out in the Universities of Ghent and Liège in 1998 focusing on the influence of detailing and of restraint conditions on the shear capacity of HC slabs⁹. Detailed descriptions and the explanations of the designs are given in the test reports.^{21,22} Each test had two 2.4m wide floor (2 HC units) spanning 3m and supported on three beams as shown in Fig. 3 (a). Each floor was independent. The floors had self weight of 3kN/m², a line load of 100kN in the middle of each of the two spans, and were exposed to 2 hours of ISO fire. Afterwards, extra load was applied to check the remaining load capacity. The parameters studied in the four tests are shown in Table 1. Only half of the floor was simulated (one 1.2m wide floor span of 3m) as shown in Fig. 3 (b). The filling of the voids at the ends was included in the model, but the peripheral ties and the detailed anchorage were not.

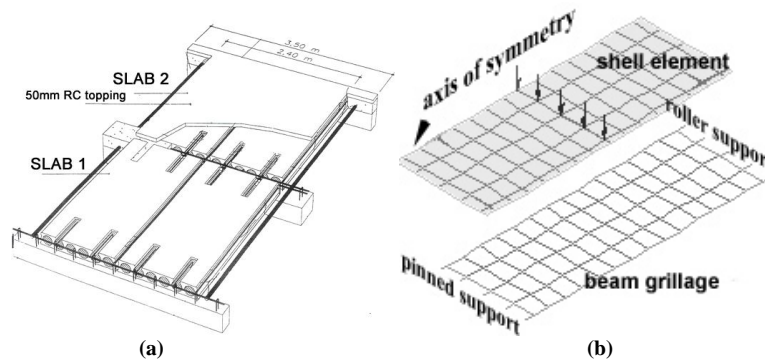

Fig. 3 – (a) Detailing of Test 1 in 1998 SSTC tests⁹ (b) illustration of the simulation model

Table 1 Studied parameters in 1998 tests in University of Ghent²¹

Parameters	Test 1	Test 2	Test 3	Test 4
HC section (type)	SP200 Ergon	VS20 Echo	VS20 Echo	SP265 Ergon
Height of HC section	200mm	200mm	200mm	265mm
Peripheral ties	none	exists	exists	none
Reinforced topping	50mm	none	none	30mm

Test 4 has been simulated using SAFIR with a different approach before². The differences between the old and new models are the presence of the transverse beams and the location of dividing the units. The new method recognises that the bottom flange is more likely to split than the web. Therefore, it is more reasonable to divide the units at the thinnest point of the flange as shown in Fig.2(a) rather than at the middle of the web. The previous

study showed that the heat transfer through the cavities in SAFIR is properly calculated and the thermal gradient given by the simulation was similar to the experimental results. Hence, the thermal gradient in the new model must also be accurate.

In all the tests, the compressive strength of the concrete in the HC units was around 45MPa, and the strands strength was 1.85GPa. The results from Tests 1 and 4 with RC topping slabs are shown in Fig.4 and 5. The level of prestressing was assumed to be 75% of the strand strength.

To check if the transverse beams increase the stiffness of the slab, the transverse beams were removed in one simulation. Fig.4 (b) shows that the presence of transverse beams has no influence on the vertical displacement in this case where the slab consists of only two units. It confirms the idea the transverse beams should only contribute to the transverse displacement, or become effective when the slab consists of multiple units over the width or the support condition at the sides become important.

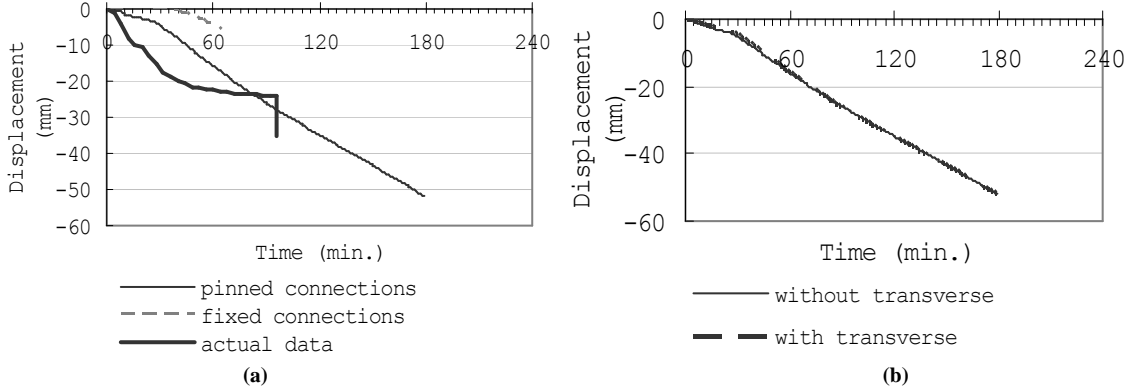

Fig. 4 – Simulation results from Test 1 (a) different support condition against actual result (b) effect of transverse beams

In Test 1, the simulation run with no rotational restraints at the ends predicted that the slab had more than 3 hours of fire resistance, but this reduces to 1 hour if there are full rotational restraints. However, in reality the support condition is one of partial rotational restraint, and the slab withstood 83min. of the fire. Fig.4(a) shows that the simulation result was not close to the experimental data²². The maximum difference between the maximum deflections obtained from simulation and the test data was 10mm. During the experiment, shear cracking was observed 7min. from the start of the experiment, and vertical cracking was observed at 12min.²². This explained the rapid increase in midspan deflection in the experiment at the early stage of the fire. The simulation model could not predict the shear displacement or failure, as shear effects are not included in the computer software used.

In Test 4, the HC unit is changed from SP200 Ergon with circular voids to SP265 Ergon with oval shaped voids, and the number of voids changed from six to five, but the applied load and other mechanical values were the same as in Test 1. The experimental result

in Fig. 5 showed that the slab could sustain up to 2 hours of ISO fire. The failure from the actual data was caused when the fire was stopped after 2 hours and more loading was added at the midspan to check the capacity. There was no shear failure or substantial shear displacement during the fire test. Therefore the simulation result matched the test data reasonably well up to 120min.. The maximum difference between the two deflections was around 5mm.

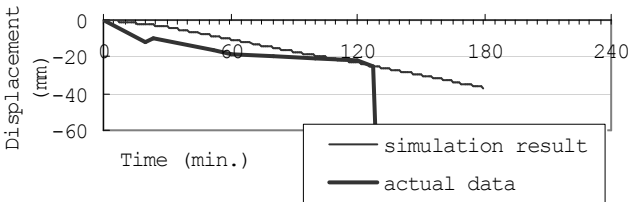

Fig. 5 – Simulation results of Test 4

4.2. Danish Prefab Concrete Association (Betonelement-Foreningen, BEF)

Three fire tests with HC slabs were conducted by BEF in 2005⁵. The purpose of these tests was to confirm if after exposing to the ISO fire for 60min., the HC slabs could still resist at least 65% of the ultimate design shear capacity in cold condition derived from the DS411 Danish Standard²³. Therefore, the applied shear force in these tests was higher than expected in a normal fire design. In these tests the fire curve followed only 60min. of the ISO fire and then stopped, and the tests continued for a further 60 to 90min. with the constant applied load. The tested specimens were 265mm thick, with no topping, spanning 3.27m as shown in Fig. 6(a) the simulation model is shown in Fig. 6(b). The HC unit in the test as shown in Fig. 7(a) was discretised as shown in Fig. 7(b).

Three load levels, 65%, 75% and 80% of the ultimate shear capacity (91.6kN/m) were used in the test. The dead weight of the HC slabs is 3.65kN/m² including joint castings.

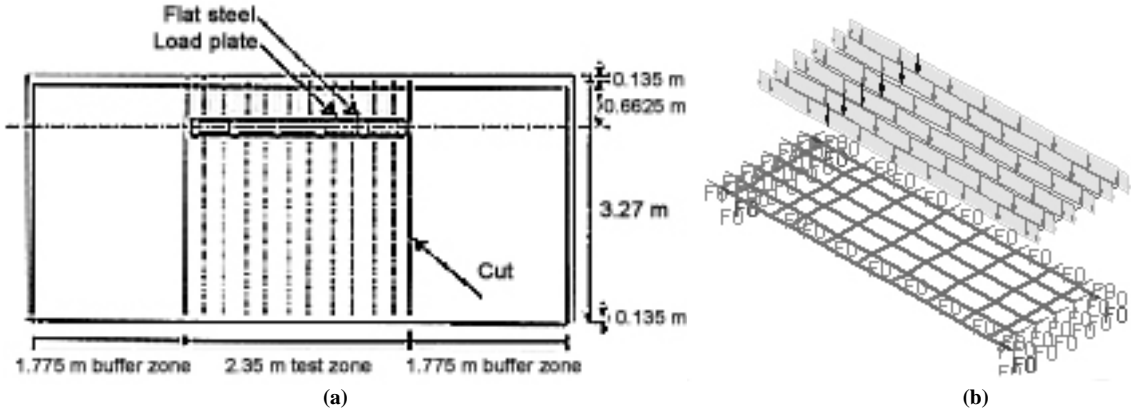

Fig. 6 – (a) original test layout² (b) SAFIR grillage model and loads for BEF 2005 tests

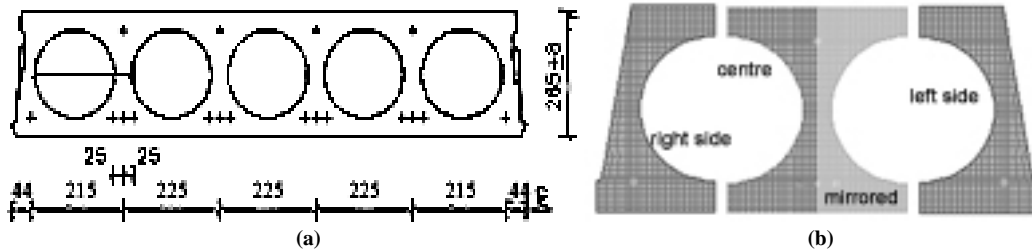

Fig. 7 – (a) HC dimension for BEF test⁵ (b) discretised model (right, web, left)

The test results showed that the HC slabs have good shear resistance under elevated temperature. The comparison between the analytical prediction and experimental results in Fig. 8 shows that the vertical displacements calculated from the simulation are close to the test data. The difference between the vertical deflection at the centre and the side of the unit in the simulations is almost the same as that from the tests. The difference between the predictions and the test data is presumed caused by shear deformation. In the case with an applied load equal to 80% of the slab's shear capacity, the slab had a shear failure after 45 minutes of ISO fire exposure. The model could not foresee the shear failure and therefore it continued to provide results after this time. The large shear force was not captured in the analysis, and the model underestimated the deflection. Nevertheless, in normal practice such high level of shear force is never designed for.

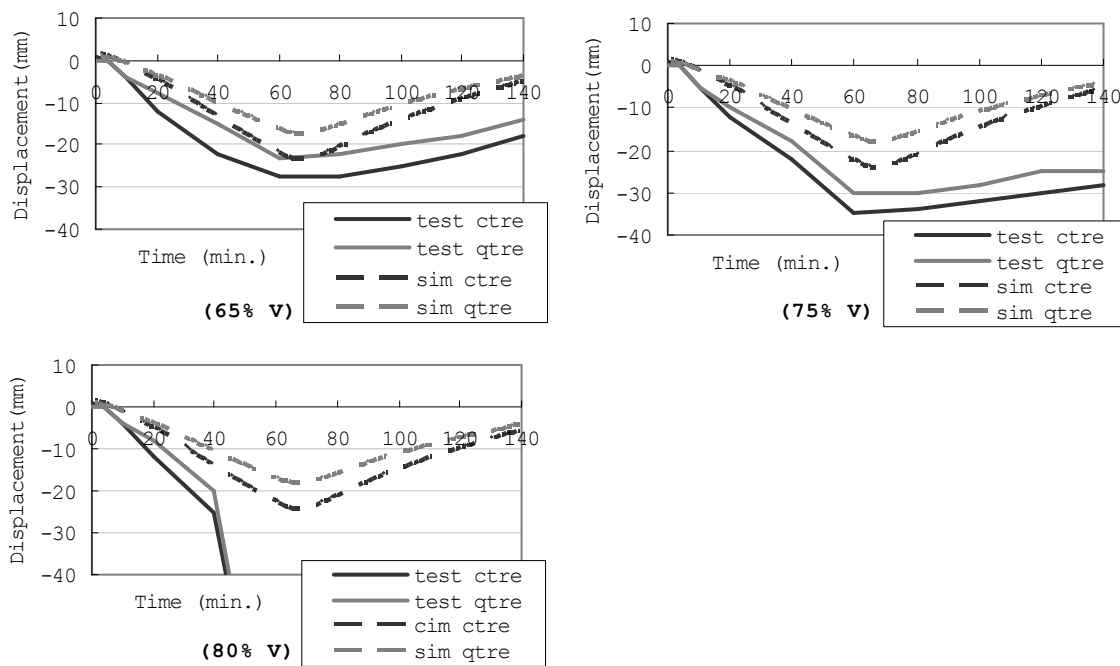

Fig. 8 – Comparison between the vertical displacements at midspan (ctre) or at the location of the point load (qtre) from simulation (sim) and test (test) results

5. STRUCTURAL SIMULATION

Currently University of Canterbury is developing several new designs to increase the earthquake resistance of HC floor systems^{24,25,26}. The proposed model is being used to check their fire resistances. The simulation shown here is based on one structure previously tested for the seismic purposes²⁵, consisting of 300mm thick HC units (300Dycore) and 75mm thick RC topping. The dimensions of the tested floor are shown in Fig. 9(a). One of the simulation models is shown in Fig. 9(b). The tested floor was 6.1m wide, but by using symmetry about one side, the total width it represented was 12.2m. The span length was also 12.2m. The surrounding beams were 400mm wide by 750mm deep. A 200mm thick in-situ RC slab was added at the side between the first HC unit and the side beam to ensure smooth transition of deformation from the flexible side beam to the rigid HC floor units²⁴.

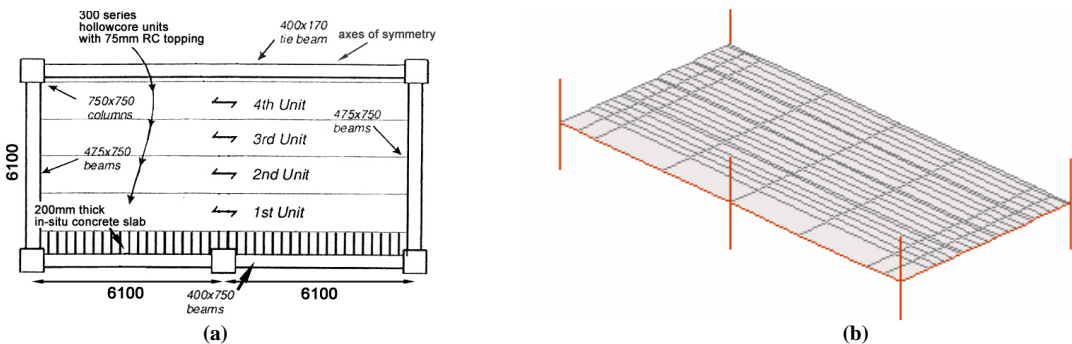

Fig. 9 – Half of the floor plan of simulated test (a) from the drawing²⁵ (b) in simulation

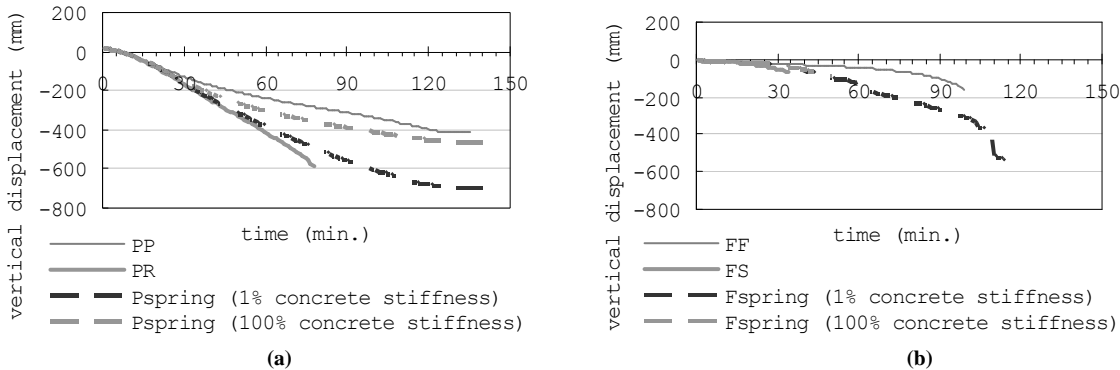

Fig. 10 – Midspan vertical displacements at the centre of the slab with different connection types: (a) without rotational restraints (b) with rotational restraints

Two parameters are studied here: the connection type at the ends of the units, and the vertical supports at the sides of the floor. Previous studies have shown that providing axial restraints can improve the fire resistance^{1,2,8,9}, and the latest experimental study in the University of Canterbury on seismic behaviour of HC floor system showed that providing rotational restraints at the ends enhances seismic performance. To study the effect of the end supports, six different support conditions were simulated: pin-pin (‘PP’), pin-roller (‘PR’),

pin-pin and a spring ('Pspring'), fix-fix ('FF'), fix-slide ('FS'), and fix-fix and a spring ('Fspring'). In this first set of analyses, supports at the side were not considered, and the piece of in-situ RC slab at the side was ignored. The results are shown in Fig. 10. Both Fig. 10(a) and (b) highlight the benefit of providing even just a little axial restraint, as the cases with no axial restraint fail much earlier than the other cases. By comparing PP and FF case these two figures, it is observed that providing rotational restraint will reduce the overall deflection, however, the fire resistance will also be reduced.

The idea behind the second set of simulations was that the membrane action inherent in two-way slabs can be taken into account if vertical supports are provided at the sides of the HC floors. The in-situ RC topping slab was included in this set of analyses. Six different situations were studied to see the effect of the vertical supports at the sides: (1) no supports at the side but fixed at the ends ('one-way supported'), (2) fixed at all four sides ('all fixed'), (3) pinned at all four sides ('all pinned'), (4) two ends fixed and sides rigidly connected to beams which are fixed at the two extremes ('with two beams'), (5) floor rigidly connected to beams at all four sides with the four corners fixed ('with all beams'), and (6) the beams connected to columns at the four corners with fixed base ('with clmn.'). The maximum vertical displacements in the slab are shown in Fig. 11.

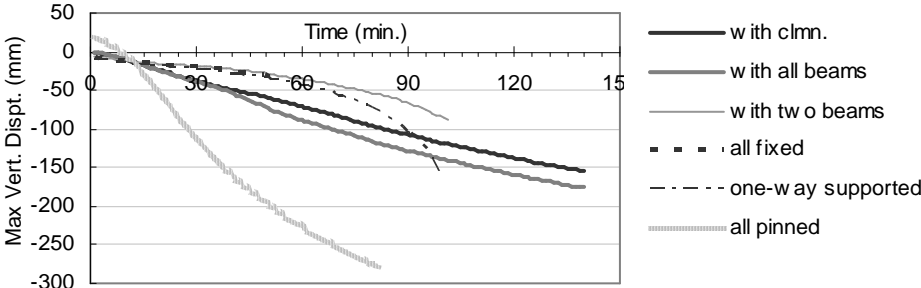

Fig. 11 – Maximum vertical displacements in the slab with different support conditions

The result confirms the finding from the previous set of simulation. Only in the case with all four sides fixed, the predicted fire resistance is less than 1 hour. The cases closer to the reality showed (i.e. 'with clmn.' and 'with all beams' cases) higher than 2 hours of resistance. The graph also show that the vertical displacement at the centre of the 'with clmn.' case is less than that of the 'with all beams' case. This is because the presence of columns allows the corners to move away thereby resulting in horizontal outward movement of the side beams. The 'all pinned' case failed earlier than the 'PP' case from Fig. 10. Further investigation has shown that this is caused by the numerical problem in the program, and it is not an indication of the real failure time.

From the results here it can be said that the best fire resistance is provided when there are partial restraints on rotational and axial deformation at all sides. The worst fire resistance is from the case with fixation at all sides (which has fire resistance of 50min. as shown in Fig.

11) Note that fully fixed support condition is also not recommended from the seismic design point of view²⁶. By comparing the ‘one-way supported’ and the ‘with two beams’ cases, the results indicate that providing vertical support along the sides reduces the maximum displacement significantly, but only slightly increase the fire resistance of the HC floor system.

6. CONCLUSIONS AND FUTURE STUDIES

A new modelling scheme is proposed to simulate the behaviour of HC floor system under fire. The new scheme uses a grillage system to model the HC unit, and a layer of shell elements to model the RC topping slab. The advantage of the new scheme is that it recognises the effects of thermal expansion in the transverse direction, and it can also model the membrane action through the topping layer.

The new model can predict the fire performance of HC slabs well, on the condition that no shear failure or significant shear displacements are present. It is expected that this new model could work better in actual building design than in the simulating test results, because shear failure or displacement is likely to be significantly reduced with the presence of axial restraints.

From the preliminary study on the HC floor design, axial restraints at the end supports are strongly recommended, but restraining rotation at the sides has little benefit on improving fire resistance. Future studies will include more detailed connections, and also investigate whether an intermediate beam to reduce the width of bay is necessary for fire safety.

7. REFERENCE

- [1] Fellingner, J.H.H., *Shear and Anchorage Behaviour of Fire Exposed Hollow Core Slabs*, DUP Science, Delft, Netherlands, 2004.
- [2] Dotreppe, J-C. and Franssen, J-M., “Precast hollow core slabs in fire: numerical simulations and experimental tests”, *3rd International Workshop “Structures in Fire”*, Ottawa, Canada, May 2004, paper S5-1
- [3] Materazzi, A. L. and Breccolotti, M., “Fire behaviour of HPLWC hollow core slabs: full scale furnace tests and numerical modelling”, *fib Task Group 4.3*, Milan, Italy, Dec, 2004
- [4] Micelli, F., Mariacongedo, P. & De Lorenzis, L. *Resistenza al Fuoco di Pannelli Cavi in Calcestruzzo Precompresso*, Internal Report, Università degli Studi di Lecce, Italy, 2005
- [5] Bef. *Hollow Core Slabs and Fire – Documentation on Shear Capacity*, Birch & Krogboe A/S, Denmark, 2005.
- [6] Andersen, N. E. and Lauridsen, D. H. *Danish Institute of Fire Technology Technical Report X 52650 Part 2 - Hollow core Concrete Slabs*, DIFT, Denmark, 1999.
- [7] Lennon, T., “Precast Hollowcore slabs in fire”, *Structural Engineer* Vol. 81 No. 8, pp.

30-35, 2003

- [8] Buchanan, A.H. *Structural Design for Fire Safety*. John Wiley & Sons, Chichester, 2001
- [9] Dotreppe, J-C., and Van Acker, A., “Shear resistance of precast prestressed hollow core slabs under fire conditions”, *1st fib Congress*, Japan, pp.149-158, 2002.
- [10] Chang, J., *Performance of Concrete Flooring under Fire in Modern Building System*, PhD Thesis, University of Canterbury, NZ, 2007 (in progress)
- [11] ENV 1992-1-2, *Eurocode 2: Design of concrete structures. prEN 1992-1-2: General rules- Structural fire design*, European Committee for Standardization, Brussels, 2002
- [12] NZS 3101:Part 1:1995, *The Design of Concrete Structures*, SNZ, Wellington, NZ, 1995
- [13] Franssen, J-M, Kodur, V.K.R. and Mason, J., *User’s Manual for SAFIR2001 Free: A Computer Program for Analysis of Structures at Elevated Temperature Conditions*, University of Liège, Belgium, 2002.
- [14] Lim, L., *Membrane action in fire exposed concrete floor systems*, PhD Thesis, University of Canterbury, NZ, 2003
- [15] Lim, L., Buchanan, A. H. and Moss, P. J., “Numerical modelling of two-way reinforced concrete slabs in fire”, *Engineering Structures*, Vol.26, pp. 1081-1091, 2004
- [16] Hambly, E.C., *Bridge Deck Behaviour*, 2nd Ed., E & FN Spon, London, 1991
- [17] West, R., *The Use of a Grillage Analogy for the Analysis of Slab and Pseudo-Slab Bridge Decks*, research report 21, Cement and Concrete Association, Bristol, England, 1973
- [18] Livesley, R.K., *Matrix Methods of Structural Analysis*, Pergamon Press, Oxford, 1964
- [19] Chang, J., “Simple method for modelling hollowcore concrete slabs under fire”, *19th Australasian Conference on Mechanics of Structures and Materials*, Christchurch, NZ, Nov. 2006.
- [20] Franssen, J-M., “Structures in fire, yesterday, today and tomorrow”, *8th International Symposium on Fire Safety Science*, Beijing, China, pp.21-35, Sept. 2005
- [21] Fib, *Résistance au Cisaillement de Dalles Alvéolées Précontraintes*. Studiecommissie SSTC. University of Liège, Belgium, 1998
- [22] Fib, *Résistance au Cisaillement de Dalles Alvéolées Précontraintes (Partie 1) –Annexes*. Studiecommissie SSTC. University of Ghent, Belgium, 1998
- [23] Danish Standards: DS411 *Norm for betonkonstruktioner*. Charlottenlund: Dansk Standard. 1999
- [24] Lindsay, R., *Experiments on the Seismic Performance of Hollow-Core Floor Systems in Precast Concrete Buildings*, ME Thesis, University of Canterbury, NZ, 2004
- [25] Matthews, J., *Alternative Load Paths for Floor Diaphragm Forces Following Severe Damage to the Supporting Beams*, PhD Thesis, University of Canterbury, NZ, 2004
- [26] MacPherson, C., *Seismic Performance and Forensic Analysis of a Precast Concrete Hollow-Core Floor Super-Assemblage*, ME Thesis, University of Canterbury, NZ, 2005