

# #57 *IN VIVO* EFFECTS OF REDUCED-SODIUM PERILYMPH PERFUSION ON HAIR CELL AND NEURAL POTENTIALS

Greg A. O'Beirne<sup>1,2</sup> and Robert B. Patuzzi<sup>1</sup>

<sup>1</sup> The Auditory Laboratory, Discipline of Physiology, University of Western Australia.

<sup>2</sup> Department of Communication Disorders, University of Canterbury.

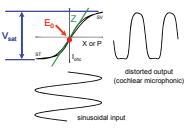
## INTRODUCTION

To determine the functional significance of the sodium-transport mechanisms of the outer hair cells (OHCs) *in vivo*, the effect of reduced perilymphatic sodium on cochlear potentials was investigated in the guinea pig by perfusion of scala tympani with a modified artificial perilymph. The Na<sup>+</sup> concentration of the artificial perilymph was reduced by almost 95% (from 150 mM to 8 mM) by substitution with choline, and resulted in an estimated 80% reduction in perilymphatic Na<sup>+</sup> on perfusion through scala tympani. OHC function was assessed using Boltzmann analysis of the low-frequency cochlear microphonic (CM) and measurement of the high-frequency summing potential (SP) recorded at the round window. Compound action potential (CAP) thresholds and waveforms were monitored at multiple frequencies, and the amplitude of the spectrum of the neural noise (SNN) in silence was measured as an indicator of spontaneous neural activity.

## METHODS

**Animal preparation:** Adult pigmented guinea pigs (*Cavia porcellus*) with normal hearing thresholds were used. All protocols were approved by the Animal Ethics Committee of the University of Western Australia (Approval No. 02/100/184). **Data acquisition:** Near-simultaneous round window recordings were made of i) CAP waveforms and thresholds at seven different tone-burst frequencies; ii) the SNN recorded in silence (in particular, the mean amplitude of the spectrum calculated between 700 and 1100 Hz); and iii) Boltzmann parameters extracted from the low-frequency CM waveform (Fig. 2; see also Patuzzi & O'Beirne, 1999).

**Figure 1:** Boltzmann analysis of the low-frequency CM uses an intense, non-traumatic, low-frequency tone (e.g. around 200 Hz) to drive the basilar-tunnel OHCs into partial saturation. The nonlinear transfer curve is then analysed using a curve-fitting process, and yields the following parameters: **V<sub>sat</sub>** – proportional to the maximal OHC receptor current for maximal excursions of the hair bundle; **Z** – a sensitivity parameter (in units of mV/Pa) giving the slope of the mechano-electrical transduction (MET) curve; and **E<sub>o</sub>** – an offset parameter (in units of mV) that gives the operating point of the MET channels on the transfer curve, and is used to indicate the quiescent angle of the OHC stereocilia.

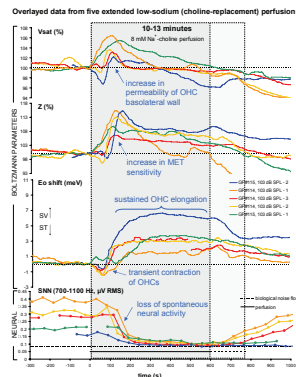


**Perilymphatic perfusions:** Artificial perilymph was pumped at 3 μL/min into scala tympani through a custom-made perfusion pipette placed in a hand-drilled hole in the otic capsule at the first turn. Another hole was made at the apex to allow this fluid to drain into the middle-ear cavity, where it was absorbed by tissue-wicks. The perfusion pipette was removed, rinsed, and refilled between applications of different solutions. The artificial perilymph was based on a formulation by Jensen et al. (1985), shown below. The solutions were warmed to 38° C and adjusted to a pH of 7.4 using HCl or NaOH. The osmolalities of the artificial perilymphs (measured by freezing-point depression) were 302 ± 6 mOsm/kg H<sub>2</sub>O. This control value was close to the perilymph osmolality of 292.9 ± 5.7 mOsm/kg H<sub>2</sub>O measured by Konishi et al. (1984). **Control perilymph composition:** 137 mM NaCl, 5 mM KCl, 12 mM NaHCO<sub>3</sub>, 11 mM glucose, 2 mM CaCl<sub>2</sub>·2H<sub>2</sub>O, 1 mM MgCl<sub>2</sub>·6H<sub>2</sub>O, 1 mM NaH<sub>2</sub>PO<sub>4</sub>·H<sub>2</sub>O. **Reduced Na<sup>+</sup> choline perilymph composition:** 142 mM choline chloride, 8 mM NaHCO<sub>3</sub>, 11 mM glucose, 2 mM CaCl<sub>2</sub>·2H<sub>2</sub>O, 1 mM MgCl<sub>2</sub>·6H<sub>2</sub>O, 4 mM KHCO<sub>3</sub>, 1 mM KH<sub>2</sub>PO<sub>4</sub>.

## RESULTS:

### BOLTZMANN ANALYSIS OF THE CM DURING REDUCED-NA<sup>+</sup> PERFUSIONS

The ≥10 minute perfusions caused a transient 2-6% increase in the maximal CM amplitude (the V<sub>sat</sub> parameter; Fig. 2), consistent with an increase in OHC basolateral permeability, a 6-15% increase in MET sensitivity (the Z parameter), and a small operating-point (E<sub>o</sub>) shift towards scala tympani that was followed by a larger sustained shift towards scala vestibuli. The rise in OHC basolateral permeability was consistent with a rise in cytosolic Ca<sup>2+</sup> concentration, due to a reduction in Ca<sup>2+</sup> efflux through the Na<sup>+</sup>/Ca<sup>2+</sup> antiporter (Ikeda et al., 1992) and a presumed opening of Ca<sup>2+</sup>-sensitive K<sup>+</sup> channels.



**Figure 2:** Boltzmann parameters and SNN amplitude recorded during five extended perfusions of 8 mM Na<sup>+</sup> choline artificial perilymph in two animals.

### CAP AMPLITUDES, WAVEFORMS & SPONTANEOUS NEURAL ACTIVITY DURING REDUCED-NA<sup>+</sup> PERFUSIONS

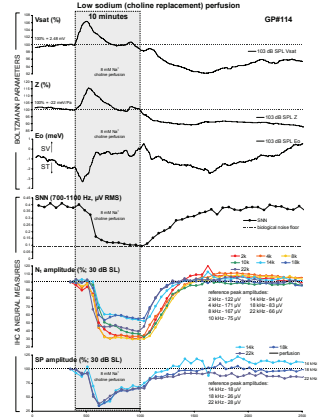
The reduced-Na<sup>+</sup> perfusions produced a drop in SNN amplitude and a large reduction in CAP amplitude at all frequencies (Fig. 3). These effects were consistent with a drop in Na<sup>+</sup> influx and spike failure. SP amplitudes also fell (consistent with a drop in basilar membrane vibration), but began to recover before the end of the perfusion, despite the sustained low Na<sup>+</sup> levels.

### MATHEMATICAL MODELLING OF REDUCED-NA<sup>+</sup> PERFUSIONS

These operating point data were not consistent with the output of our mathematical model of OHC regulation (O'Beirne, 2005; O'Beirne and Patuzzi, *submitted*). In the model, an homogenous pool of intracellular Ca<sup>2+</sup> controls both OHC basolateral permeability (via Ca<sup>2+</sup>-gated K<sup>+</sup> channels) and slow-motile contraction (Dulon et al., 1990). The model predicted that the presumed rise in intracellular Ca<sup>2+</sup> following the low-Na<sup>+</sup> perfusions would cause a slow-motile OHC contraction (Figs. 5 and 6).

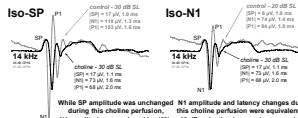
One solution is to divide OHC cytosolic calcium into two pools: a "basolateral permeability control pool" (BPCP) which has no slow-motile machinery, and a "contraction control pool" (CCP), which controls slow motility but lacks Na<sup>+</sup>/Ca<sup>2+</sup> antiports, ACh-sensitive Ca<sup>2+</sup> channels & Ca<sup>2+</sup>-sensitive K<sup>+</sup> channels. In this two-pool model, a drop in perilymphatic Na<sup>+</sup> would increase BPCP Ca<sup>2+</sup>, open Ca<sup>2+</sup>-sensitive K<sup>+</sup> channels and increase basolateral permeability and V<sub>sat</sub>. The resulting hyperpolarization would cause an electromotile expansion of the OHC, and would also close the CCP's L-type Ca<sup>2+</sup> channels, reducing CCP Ca<sup>2+</sup> and causing further slow-motile expansion.

Both of these predictions are consistent with our experimental observations.

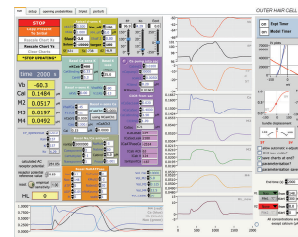


**Figure 3:** A representative result for a 10-minute perfusion of 8 mM Na<sup>+</sup> choline artificial perilymph. Shown here are the Boltzmann parameters describing mechano-electrical transduction, the spectrum of the neural noise (SNN) amplitude, and the amplitudes of the N1 CAP peak and the summing potential.

### Comparison of CAP waveforms shows neural effect in addition to minor mechanical effect



**Figure 4:** The observed changes in CAP waveforms are not explicable by a simple decrease in cochlear gain, because comparison of low-Na<sup>+</sup> waveforms with control waveforms evoked with lower sound levels (to mimic lower-amplitude BM vibration) highlight several remaining differences.



**Figure 5:** Simulated perfusions of low-Na<sup>+</sup> perilymph were carried out in our mathematical model of OHC regulation by the systematic and timed variation of the extracellular Na<sup>+</sup> concentration parameter. For perilymphatic perfusion, estimates of the time-course of perfusate concentration were imported from the Washington University Cochlear Fluids Simulator (v1.6h; Salt, 2002).

## DISCUSSION

To summarise, the reduced-Na<sup>+</sup> perfusions had a distinct neural effect in addition to the mechanical effects revealed by the Boltzmann analysis of the CM. This was indicated by the large drop in SNN and CAP amplitude in cases where the changes in the Boltzmann parameters were relatively minor. Our CAP data agree with those of Salt and Konishi (1982), who found that both intravenous injection and perilymphatic perfusion of the sodium channel blocker amiloride caused a 65% drop in the CAP.

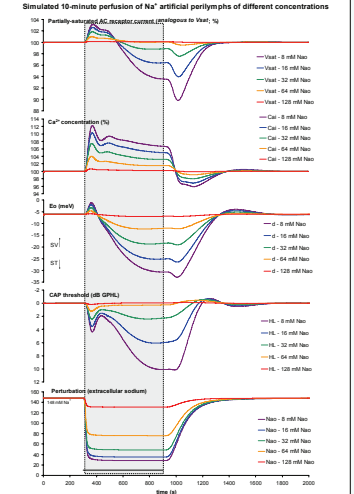
The observed changes in the Boltzmann parameters (except for the operating point) were consistent with an increase in cytosolic Ca<sup>2+</sup> concentration. This Ca<sup>2+</sup> increase was probably due to a drop in Ca<sup>2+</sup> efflux through the Na<sup>+</sup>/Ca<sup>2+</sup> antiporter rather than any efferent-like effect caused by the direct action of choline on the ACh-sensitive Ca<sup>2+</sup> channel in the basolateral wall. In experiments not shown here i) the blockade of the ACh-sensitive Ca<sup>2+</sup> channels by hexamethonium or strychnine produced no difference in the effects observed, and ii) the use of a different substitution ion (NMDG<sup>+</sup>) also produced similar effects.

The prolonged operating point shift towards scala vestibuli was not consistent with our mathematical model of OHC regulation, which predicted a slow operating point shift toward scala tympani. However, the predicted changes in basolateral permeability were consistent with the experimental data.

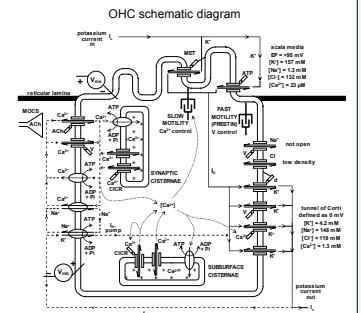
We suggest a two-pool model of Ca<sup>2+</sup> control within OHCs may produce better agreement between experiments and our model.

## REFERENCES

Dulon, D., Zajic, G., Schacht, J., 1990. Increasing intracellular free calcium induces circumferential contractions in isolated cochlear outer hair cells. *J. Neurosci.* 10(4):1388-1397.  
 Ikeda, K., Saito, Y., Nishiyama, A., Takasaka, T., 1992. Na<sup>+</sup>-Ca<sup>2+</sup> exchange in the isolated cochlear outer hair cells of the guinea-pig studied by fluorescence image microscopy. *Plüger Arch.* 420(5):603-609.  
 Jensen, G.L., Bobbin, R.P., Thalmann, R., 1985. Potassium-induced release of endogenous amino acids in the guinea pig cochlea. *J. Neurochem.* 44(6):1845-1853.  
 Konishi, T., Harris, P.E., Mori, H., 1984. Water permeability of the endolymph-perilymph barrier in the guinea pig cochlea. *Hear. Res.* 15(1):51-58.  
 O'Beirne, G.A., 2005. Mathematical modelling and electrophysiological monitoring of the regulation of cochlear amplification. PhD Thesis, Physiology, School of Biomedical and Chemical Sciences, University of Western Australia, Nedlands. <http://theses.library.uwa.edu.au/au:au:2020/0115>  
 Patuzzi, R., 1988. The Goldman-Hodgkin-Katz equation and graphical 'load line' analysis of low-frequency outer hair cells. *Hear. Res.* 125(1-2):71-97.  
 Patuzzi, R., O'Beirne, G.A., 1999. Boltzmann analysis of CM waveforms using virtual instrument software. *Hear. Res.* 133(1-2):155-159.  
 Salt, A.N., 2002. Simulation of methods for drug delivery to the cochlear fluids. *Adv. Otorhinolaryngol.* 59:140-148.  
 Salt, A.N., Konishi, T., 1982. Functional importance of sodium and potassium in the guinea pig cochlea studied with amiloride and tetraethylammonium. *Jpn. J. Physiol.* 32(2):219-230.



**Figure 6:** Results from our mathematical model of OHC regulation showing the predicted effects of the perfusion of low-sodium artificial perilymphs (various Na<sup>+</sup> concentrations) through scala tympani. Note that while the saturated AC receptor current predictions were consistent with the experimental results (V<sub>sat</sub> in Figs. 2 and 3), the predicted operating point (E<sub>o</sub>) shifts were in the opposite direction from those observed experimentally.



**Figure 7:** The main ionic transport mechanisms present in outer hair cells (adapted from Patuzzi, 1998), showing representations of fast and slow somatic motility, apical and basolateral transmembrane voltages (V<sub>ms</sub> and V<sub>ms'</sub>), and the presumed ionic concentrations of scala media and the tunnel of Corti.